

AP[®] Environmental Science

Practice Exam

The questions contained in this AP[®] Environmental Science Practice Exam are written to the content specifications of AP Exams for this subject. Taking this practice exam should provide students with an idea of their general areas of strengths and weaknesses in preparing for the actual AP Exam. Because this AP Environmental Science Practice Exam has never been administered as an operational AP Exam, statistical data are not available for calculating potential raw scores or conversions into AP grades.

This AP Environmental Science Practice Exam is provided by the College Board for AP Exam preparation. Teachers are permitted to download the materials and make copies to use with their students in a classroom setting only. To maintain the security of this exam, teachers should collect all materials after their administration and keep them in a secure location. Teachers may not redistribute the files electronically for any reason.

Contents

Directions for Administration	ii
Section I: Multiple-Choice Questions	1
Section II: Free-Response Questions	22
Student Answer Sheet for Multiple-Choice Section	26
Multiple-Choice Answer Key	27
Free-Response Scoring Guidelines.....	28

The College Board: Connecting Students to College Success

The College Board is a not-for-profit membership association whose mission is to connect students to college success and opportunity. Founded in 1900, the association is composed of more than 5,000 schools, colleges, universities, and other educational organizations. Each year, the College Board serves seven million students and their parents, 23,000 high schools, and 3,500 colleges through major programs and services in college admissions, guidance, assessment, financial aid, enrollment, and teaching and learning. Among its best-known programs are the SAT[®], the PSAT/NMSQT[®], and the Advanced Placement Program[®] (AP[®]). The College Board is committed to the principles of excellence and equity, and that commitment is embodied in all of its programs, services, activities, and concerns.

Visit the College Board on the Web: www.collegeboard.com.

AP Central is the official online home for the AP Program: apcentral.collegeboard.com.

AP[®] Environmental Science Directions for Administration

The AP Environmental Science Exam is three hours in length and consists of a multiple-choice section and a free-response section.

- The 90-minute multiple-choice section contains 100 questions and accounts for 60 percent of the final grade.
- The 90-minute free-response section contains 4 questions and accounts for 40 percent of the final grade.

A 10-minute break should be provided after Section I is completed.

The actual AP Exam is administered in one session. Students will have the most realistic experience if a complete morning or afternoon is available to administer this practice exam. If a schedule does not permit one time period for the entire practice exam administration, it would be acceptable to administer Section I one day and Section II on a subsequent day.

Total scores on the multiple-choice section are based only on the number of questions answered correctly. No points are deducted for incorrect answers and no points are awarded for unanswered questions.

- The use of calculators, or any other electronic devices, is not permitted during the exam.
- It is suggested that the practice exam be completed using a pencil for the multiple-choice section and a pen for the free-response section to simulate an actual administration.
- Teachers will need to provide paper for the students to write their free-response answers. Teachers should provide directions to the students indicating how they wish the responses to be labeled so the teacher will be able to associate the student's response with the question the student intended to answer.
- Remember that students are not allowed to remove any materials, including the free-response questions or their scratch work, from the testing site.

Section I

Multiple-Choice Questions

ENVIRONMENTAL SCIENCE

Section I

Time—1 hour and 30 minutes

Part A

Directions: Each set of lettered choices below refers to the numbered questions or statements immediately following it. Select the one lettered choice that best answers each question or best fits each statement and then fill in the corresponding box on the student answer sheet. A choice may be used once, more than once, or not at all in each set.

Questions 1-3 refer to the labeled locations on the map.

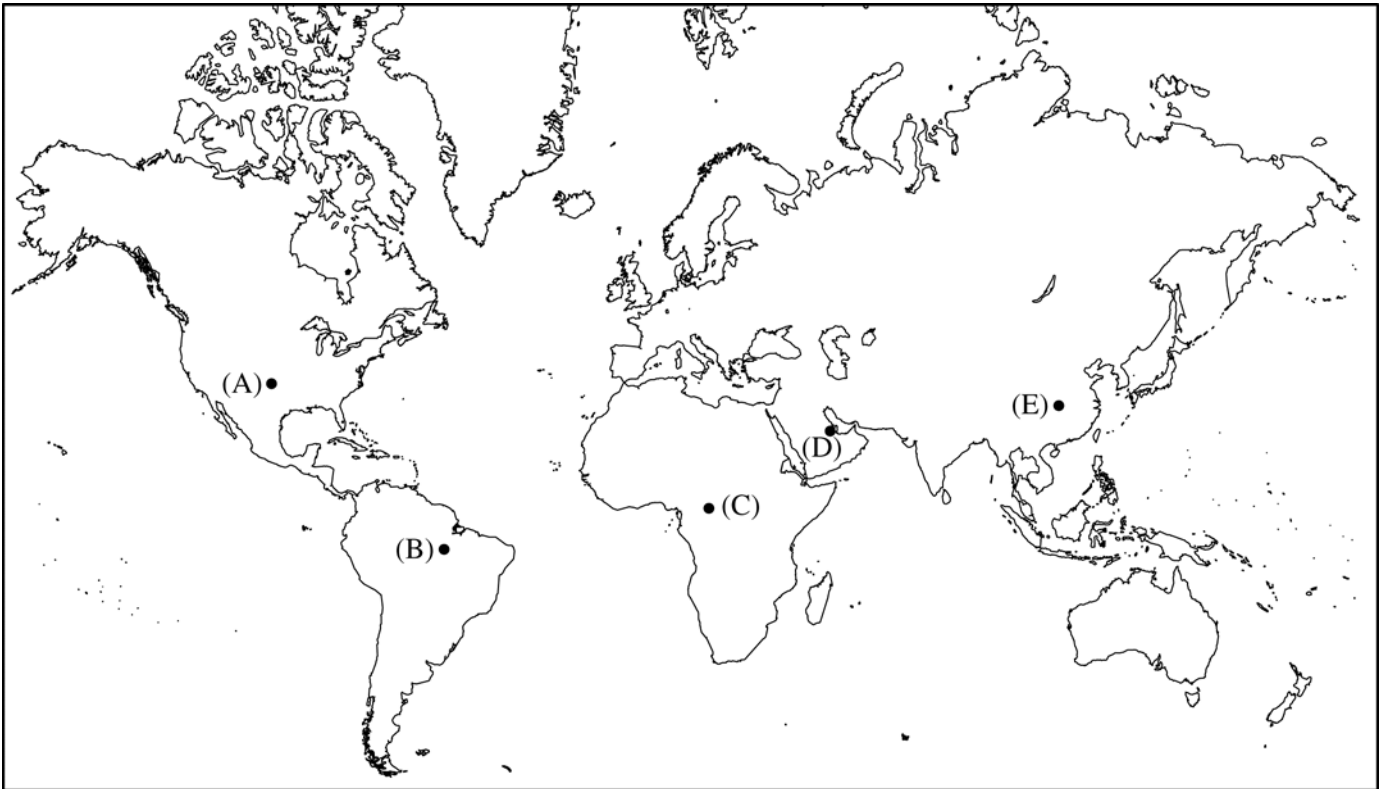

1. This area has the lowest amount of naturally available freshwater per capita.
2. The largest hydroelectric dam in the world is located on one of the world's longest rivers in this area.
3. Desalination is used to supply much of this region with freshwater.

GO ON TO THE NEXT PAGE.

Questions 4-6 refer to the gases listed below.

- (A) H₂O
- (B) CO₂
- (C) CH₄
- (D) O₃
- (E) CCl₂F₂

- 4. The most abundant nonanthropogenic greenhouse gas
- 5. A greenhouse gas that is exclusively anthropogenic
- 6. A greenhouse gas that, in the lower troposphere, is formed by photochemical reactions

Questions 7-10 refer to the energy sources listed.

- (A) Uranium-238
- (B) Coal
- (C) Natural gas
- (D) Oil
- (E) Solar

- 7. Is primarily responsible for acid rain in the northeast United States
- 8. Is renewable
- 9. Currently proven global reserves are expected to be largely exhausted within the next 50 years.
- 10. Occurs naturally in bedrock and leads to the formation of radon

Questions 11-14 refer to the layers of Earth's atmosphere in the temperature profile shown below.

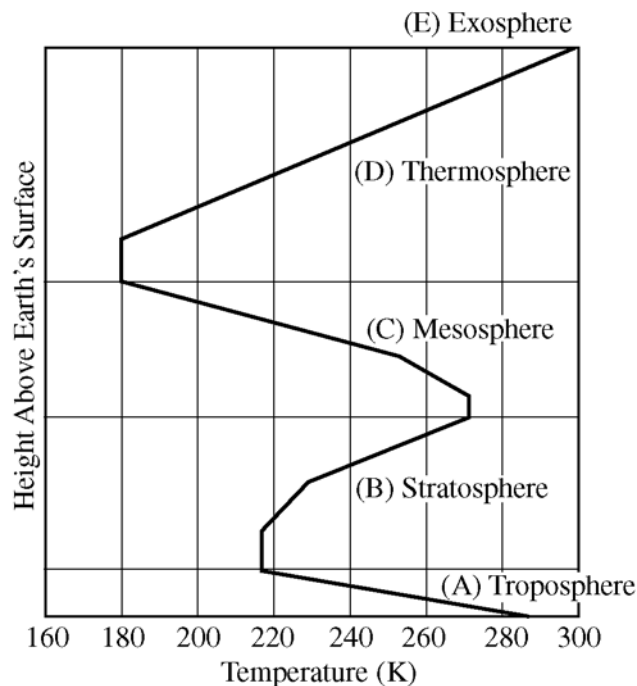

- 11. Region where the protective ozone layer is located
- 12. Region that contains the majority of molecules in the atmosphere
- 13. Region largely responsible for the weather experienced at the Earth's surface
- 14. Region with the lowest atmospheric pressure

GO ON TO THE NEXT PAGE.

Part B

Directions: Each of the questions or incomplete statements below is followed by five suggested answers or completions. Select the one that is best in each case and place the letter of your choice in the corresponding box on the student answer sheet.

Questions 15-16

A one-hectare pond is sampled in early September. The sample yields 1 small catfish as well as 17 benthic invertebrates that represent 10 species.

15. Which of the following can be estimated from the sample for the invertebrates in the pond?
- (A) The species richness
 - (B) The pond's productivity
 - (C) The uniformity of species distribution in the pond
 - (D) The degree of disturbance
 - (E) The stability of the ecosystem
16. If the pond is resampled a year later, which of the following would best indicate that the pond had been adversely affected by adjacent development?
- (A) An uncommon species has become more numerous.
 - (B) An increase in low-tolerance species has occurred.
 - (C) A decrease in high-tolerance species has occurred.
 - (D) Phylogenetic diversity has increased.
 - (E) The biodiversity of the pond has decreased.
17. Which of the following is an environmental problem associated with abandoned coal mines?
- (A) Thermal pollution of streams in the area
 - (B) Acid drainage due to leaching of spoil heaps by rainwater
 - (C) Air pollution caused by smog from ozone formation
 - (D) Alkaline solutions that pollute streams
 - (E) Released nutrients that cause eutrophication into streams
18. Some solar energy systems produce high-temperature water for industrial applications and produce steam to run turbines that generate electricity. What type of solar energy system is needed for these kinds of applications?
- (A) A flat-panel solar collector system
 - (B) A solar collector system using mirrors or lenses to concentrate sunlight
 - (C) A passive solar system that uses building design to block summer sunlight
 - (D) A flat non-tracking array of photovoltaic panels
 - (E) A passive solar system that uses building design to collect winter sunlight

GO ON TO THE NEXT PAGE.

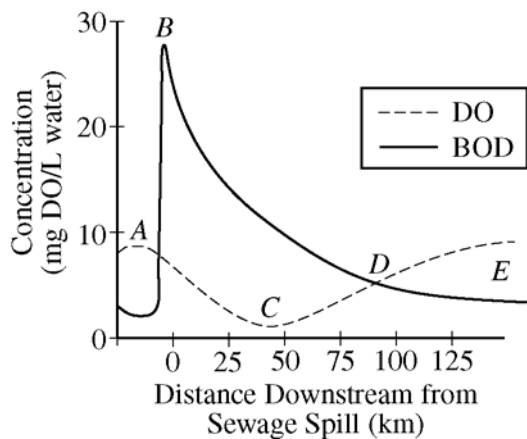

19. The graph above shows the effect of sewage on biological oxygen demand (BOD) and dissolved oxygen (DO) in a flowing stream. The smallest fish populations will most probably be found at point

- (A) A
- (B) B
- (C) C
- (D) D
- (E) E

20. Which of the following regions of the ocean is LEAST likely to contain photosynthetic organisms?

- (A) Intertidal zone
- (B) Zone of coastal upwelling
- (C) Pelagic zone
- (D) Euphotic zone
- (E) Abyssal zone

Questions 21-22 refer to the pH scale below.

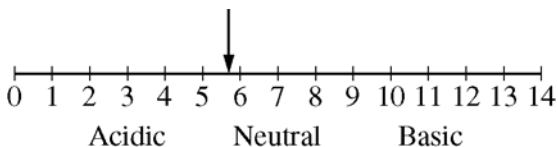

21. The arrow represents the approximate pH of which of the following?

- (A) Lemon juice
- (B) Ammonia
- (C) Distilled water
- (D) Highly acidic rainfall
- (E) Normal rainfall

22. The concentration of H^+ ions in a solution with a pH value of 4 is how many times as great as the concentration of H^+ ions in a solution with a pH value of 7 ?

- (A) 1
- (B) 10
- (C) 100
- (D) 1,000
- (E) 10,000

23. Which of the following is the best example of an energy storage element in a solar energy system?

- (A) The photovoltaic array in a solar electric system
- (B) The overhang that blocks sunlight in a passively cooled home
- (C) The insulated windows in a passively heated solar home
- (D) The sun-tracking mirrors in a power tower system
- (E) The hot water tank in a solar hot water system

24. Which of the following is the correct order of soil particles in order of increasing size?

- (A) Clay—sand—silt
- (B) Clay—silt—sand
- (C) Sand—clay—silt
- (D) Sand—silt—clay
- (E) Silt—clay—sand

25. Which of the following is a commercially used method for harvesting trees and is most likely to lead to a fragmented landscape with serious impacts on biodiversity?

- (A) Selective cutting
- (B) Clear-cutting
- (C) Shelter-wood cutting
- (D) Slash and burn clearing
- (E) Gleaning

26. All of the following are commonly used to deal with the side effects of eutrophication in lakes EXCEPT

- (A) applying herbicides to kill nuisance plants
- (B) dredging out lakes to deepen them
- (C) pumping oxygen into the lowest layers of water
- (D) introducing insects that eat certain nuisance plants
- (E) adding nitrates

GO ON TO THE NEXT PAGE.

Questions 27-29

A laboratory experiment was done to show the effects of organic waste on the dissolved oxygen (DO) content in water. Five tanks were set up, each containing fresh water and a small amount of single-celled green algae. Specified amounts of organic waste were added to the tanks. The results below show the amount of DO in each tank after a period of one week.

	Tank 1	Tank 2	Tank 3	Tank 4	Tank 5
Initial DO	10 ppm	10 ppm	10 ppm	10 ppm	10 ppm
Amount of organic waste added	0 g	10 g	20 g	30 g	40 g
DO after one week	10 ppm	10 ppm	8 ppm	5 ppm	0 ppm

27. What is the main purpose for the experiment?
- (A) To determine how much O₂ the algae can produce
 - (B) To show how much CO₂ is consumed by decomposition
 - (C) To collect data to determine how waste in water can be useful
 - (D) To demonstrate that initial DO is not important
 - (E) To observe the effect of organic waste on DO
28. Why did the DO after one week decrease as the amount of waste increased?
- (A) The algae could not consume the waste fast enough.
 - (B) The turbidity of the water increased, and the algae population increased.
 - (C) The algae multiplied and then died and decomposed.
 - (D) The CO₂ increased due to algal respiration.
 - (E) The oxygen came out of solution into the air in the laboratory.
29. Which of the following would best improve the validity of the experiment?
- (A) Eliminating tank 1, because the DO stayed the same
 - (B) Observing the results of adding organic waste to tanks containing salt water
 - (C) Repeating the experiment several times and comparing the results
 - (D) Increasing the amounts of green algae in each of the tanks, with tank 5 having the greatest amount
 - (E) Adding different types of waste to each tank and then checking the results

GO ON TO THE NEXT PAGE.

Questions 30-32 refer to the table below, which shows population, area, and energy use of several countries.

Country	Population (millions)	Approximate Total Land Area (million km ²)	Total Annual Electricity Usage (10 ¹⁰ kWh)
Australia	19.7	8.2	22
Bangladesh	144	0.14	1.6
China	1,295	9.6	150
Ethiopia	70	1.12	0.20
India	1,000	3.29	60
United States	300	9.63	400

30. The country with the highest population density is

- (A) Australia
- (B) Bangladesh
- (C) China
- (D) Ethiopia
- (E) India

31. The country with a population about three times that of the United States is

- (A) Australia
- (B) Bangladesh
- (C) China
- (D) Ethiopia
- (E) India

32. On an annual basis, the per capita electricity usage in Ethiopia is approximately what percent of the per capita electricity usage in the United States?

- (A) 0.2
- (B) 10
- (C) 50
- (D) 100
- (E) 200

GO ON TO THE NEXT PAGE.

33. How does the burning of fossil fuels contribute to the net increase in atmospheric carbon?
- (A) Photosynthesis is reduced by virtue of increased smoke and haze.
 - (B) Carbon released by the burning is not in a form that can be readily absorbed by plants, leaving residual carbon in the atmosphere.
 - (C) Carbon that has been sequestered underground is added to the carbon cycling between the atmosphere and the biosphere.
 - (D) Carbon released by the burning is more easily absorbed in the atmosphere than that produced by natural means.
 - (E) Carbon released by the burning increases plant growth, producing more carbon for the atmosphere.
34. Which of the following statements best describes the concept of phytoremediation?
- (A) The use of plants to absorb and accumulate toxic materials from the soil
 - (B) The concentration of toxic materials in the tissue of organisms as they move through successive trophic levels
 - (C) The breaking down of toxic materials in the natural environment by sunlight
 - (D) The remediation of an ecosystem degraded by human activities back to its original structure and composition
 - (E) The use of bacteria and other microorganisms to break down hazardous waste
35. Which of the following elements is most likely to limit primary production in freshwater lakes?
- (A) Oxygen
 - (B) Calcium
 - (C) Phosphorus
 - (D) Carbon
 - (E) Iron
36. Which of the following practices would have the biggest impact on achieving global sustainability?
- (A) Recycling aluminum cans
 - (B) Using fuel-efficient vehicles
 - (C) Replanting deforested areas
 - (D) Reducing human population size
 - (E) Developing ecotourism venues
37. Some automobiles in the United States are fueled by natural gas. What is the primary environmental advantage of natural gas relative to gasoline as a transportation fuel?
- (A) The United States has 60% of the world's proven natural gas reserves.
 - (B) Natural gas is a renewable resource that is usually produced from corn and other agricultural products.
 - (C) When natural gas is burned in an automobile engine, the only emission product is water vapor.
 - (D) Natural gas combustion emits fewer pollutants.
 - (E) There is an extensive retail distribution network for natural gas so that natural gas is available at most gas stations.
38. Which of the following is used to reduce SO₂ emissions from coal-burning power plants?
- (A) Catalytic converters
 - (B) Ultrafine mechanical filters
 - (C) Electrostatic precipitators
 - (D) Wet-scrubber units
 - (E) Afterburners
39. Global climate change occurs because increasing concentrations of greenhouse gases in
- (A) the troposphere absorb outgoing IR radiation
 - (B) the stratosphere absorb outgoing IR radiation
 - (C) the troposphere absorb incoming UV radiation
 - (D) the stratosphere absorb incoming UV radiation
 - (E) neither the troposphere nor the stratosphere absorb incoming UV radiation
40. As a country goes through the demographic transition, the greatest rate of population growth takes place during which phase?
- (A) The preindustrial
 - (B) The pretransitional
 - (C) The transitional
 - (D) The industrial
 - (E) The postindustrial

GO ON TO THE NEXT PAGE.

WORLD FOSSIL FUEL CONSUMPTION
1950–2002

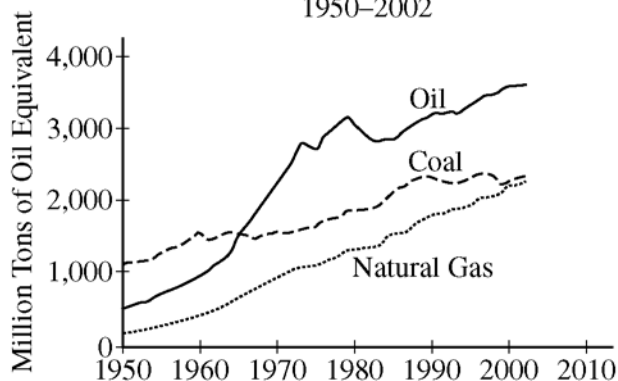

41. According to the data plotted in the graph above, which of the following is true about the increase in world fossil fuel consumption between 1965 and 1980 ?
- Increases in oil, coal, and natural gas consumption occurred at about the same rate.
 - Increases in oil and coal consumption outpaced the increase in natural gas consumption.
 - The increase in coal consumption outpaced the increases in oil and natural gas consumption.
 - The increase in natural gas consumption outpaced the increases in oil and coal consumption.
 - The increase in oil consumption outpaced the increases in coal and natural gas consumption.
42. The use of nitrogen-based fertilizers in the Midwestern United States is a major contributing factor to which of the following?
- Spread of the West Nile virus
 - Hypoxia in the Gulf of Mexico
 - Water shortages in communities near the Great Lakes
 - Soil erosion in Texas
 - The increase in severe storms in the Southeastern United States
43. Although levels of CFCs in the atmosphere are much lower than those of CO_2 , CFCs are still potent greenhouse gases because they
- remain in the atmosphere for only a brief time
 - lack natural sources
 - are much more efficient at absorbing thermal radiation
 - circulate through the troposphere more easily than CO_2 does
 - are more difficult to remove from smokestacks and tailpipes
44. After 200 million years, only 1/16 of the original amount of a particular radioactive waste will remain. The half-life of this radioactive waste is how many million years?
- 12.5
 - 25
 - 50
 - 75
 - 100
45. Which of the following is a true statement about the total fertility of a society?
- The total fertility of a society is the difference between the crude birth rate and the crude death rate.
 - The total fertility of a society is the number of children necessary for a couple to replace themselves in the next generation.
 - The total fertility of a society is positively correlated with the average education of women.
 - The total fertility of a society is negatively correlated with the number of women of child-bearing age.
 - The total fertility of a society decreases as the society progresses through the demographic transition.
46. The separation of the various components of crude oil in refineries is accomplished primarily by taking advantage of differences in which of the following?
- The densities of the components
 - The boiling points of the components
 - The solubility of the components
 - The sulfur content of the components
 - The viscosities of the components

GO ON TO THE NEXT PAGE.

47. Biological controls are frequently used to replace persistent chemical pesticides. Which of the following represents the greatest potential risk of using biological controls?
- (A) The control agent attacks not only its intended target but also beneficial species.
 - (B) The control agent mutates and is no longer an effective control agent.
 - (C) Repeated applications or introductions are required to eliminate the pest population.
 - (D) Residual pesticides in the environment kill the control agent before it can eradicate the pest.
 - (E) Biological controls prove to be more costly to use than chemical pesticides.
48. Which of the following federal laws specifically deals with the cleanup of abandoned hazardous waste sites?
- (A) Clean Air Act
 - (B) Clean Water Act
 - (C) Safe Drinking Water Act
 - (D) Resource Conservation and Recovery Act
 - (E) Comprehensive Environmental Responsibility Compensation and Liability Act
49. Which of the following is the best description of a population that has a stable age distribution?
- (A) A large population that is growing at a constant rate
 - (B) A large population with a negative growth rate
 - (C) A population that is in the early stages of logistic population growth
 - (D) A growing population in which the proportions of individuals in the different age classes remain constant
 - (E) A small population that has not yet achieved exponential growth
50. The majority of atmospheric mercury is produced by
- (A) medical waste incinerators
 - (B) volatilization of lead-based paint
 - (C) coal-burning power plants
 - (D) runoff from thermometer factories
 - (E) municipal waste incinerators
51. Step P. Water is passed through a screen to remove debris.
- Step Q. Pathogenic organisms are killed by chlorination, UV, or ozone.
- Step R. Suspended particles clump and settle out.
- Step S. A floccing agent, such as alum, is added to the water.
- The processes described above are steps in the purification and treatment of municipal wastewater. The steps are listed in random order. Which of the following lists the steps in the correct sequence?
- (A) S → P → R → Q
 - (B) S → R → P → Q
 - (C) Q → S → P → R
 - (D) P → Q → R → S
 - (E) P → S → R → Q
52. The process of extracting and separating gold in remote regions often results in environmental contamination with which of the following?
- (A) Ozone
 - (B) Cyanide
 - (C) CFCs
 - (D) Asbestos
 - (E) Selenium
53. The atmospheric concentration of carbon dioxide increased from 278 ppm in 1790 to 383 ppm in 2007. What is the approximate percent increase in carbon dioxide concentration from 1790 to 2007?
- (A) 38%
 - (B) 50%
 - (C) 92%
 - (D) 105%
 - (E) 138%

GO ON TO THE NEXT PAGE.

54. Which of the following is true of the Clean Air Act?
- (A) It was passed by Congress during the early 1950s.
 - (B) It regulates the amount of CO₂ emitted by power plants.
 - (C) It has remained largely unmodified since it was originally signed into law.
 - (D) It established a cap-and-trade program for SO₂ in 1990.
 - (E) It is set to expire in 2015.

55. Which of the following is true of farm-raised salmon?
- (A) They are more genetically diverse than their wild counterparts.
 - (B) They seldom escape from their containment areas.
 - (C) They have no impact on the quality of the water in which they are raised.
 - (D) They are often infected with parasites and sea lice.
 - (E) They are maintained at lower population densities than are wild salmon.

56. Which of the following is the best illustration of the pesticide treadmill?
- (A) Sequence of several pesticides used by farmers to maximize effectiveness
 - (B) Increased use of pesticides to eradicate genetically resistant pests
 - (C) Biomagnification of pesticides in the fatty tissue of primary consumers
 - (D) Movement of pesticides following their percolation into the groundwater
 - (E) Process that is used to manufacture pesticides

Questions 57-59 refer to the following.

The town of Fremont Center shares its power plant with the towns of West Fremont and East Fremont. Information about the three towns is shown in the table below. The maximum capacity of the existing power plant is 2,000 MW.

POPULATION AND ELECTRIC POWER DEMAND IN THE FREMONTS

Town	Population Growth Rate	Population Size	Per Capita Power Demand
East Fremont	Zero	50,000	10 kW
West Fremont	1.75% per year	75,000	4 kW
Fremont Center	3.5% per year	200,000	5 kW

57. The number of years that the power plant will be capable of supplying all of the demand for energy in the three cities is nearest to
- (A) 0.5 year
 - (B) 5 years
 - (C) 15 years
 - (D) 25 years
 - (E) 70 years
58. Assuming per capita demand remains the same, what will be the approximate power demand in Fremont Center in 40 years?
- (A) 1,000 MW
 - (B) 2,000 MW
 - (C) 3,000 MW
 - (D) 4,000 MW
 - (E) 5,000 MW
59. The percent of the total available power currently being used by West Fremont is nearest to
- (A) 5%
 - (B) 10%
 - (C) 15%
 - (D) 25%
 - (E) 50%

GO ON TO THE NEXT PAGE.

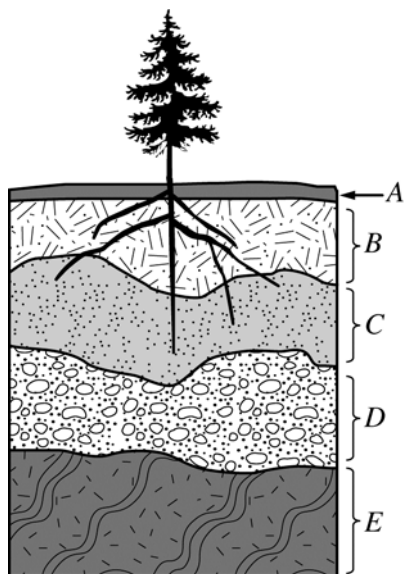

60. Which of the lettered choices in the soil profile above represents the region with the greatest concentration of organic material?

- (A) A
- (B) B
- (C) C
- (D) D
- (E) E

61. Some toxic compounds are ingested and retained in the tissues. These pollutants pose special risks to humans and other organisms high on the food chain because of which process?

- (A) Synergism
- (B) Compound contamination
- (C) Biomagnification
- (D) Threshold effect
- (E) Carcinogenesis

62. Which of the following is true of sewage treatment plants in the United States?

- (A) They release wastewater before solids are removed from the sewage.
- (B) They use stormwater runoff to assist in the treatment process.
- (C) They are not designed to remove pharmaceutical chemicals from wastewater.
- (D) They have largely eliminated cultural eutrophication in Chesapeake Bay.
- (E) They release wastewater that is not regulated by the Clean Water Act.

63. Defining characteristics of a wetland involve which of the following?

- I. Hydrology
- II. Soil type
- III. Species composition

- (A) I only
- (B) II only
- (C) I and II only
- (D) II and III only
- (E) I, II, and III

64. Which of the following is an appropriate remediation strategy for removing radon gas from the home?

- (A) Use filtered water for drinking and bathing.
- (B) Do not occupy the basement of the home.
- (C) Place monitors in suspect areas of the home.
- (D) Remove and replace soil in crawl spaces under the home.
- (E) Seal or ventilate places where radon enters the living space.

GO ON TO THE NEXT PAGE.

Questions 65-66 refer to the graph below showing the relationship between the induction of cancer in breast cells and the concentration of anastrozole.

RESPONSE OF BREAST CANCER CELLS TO ANASTROZOLE

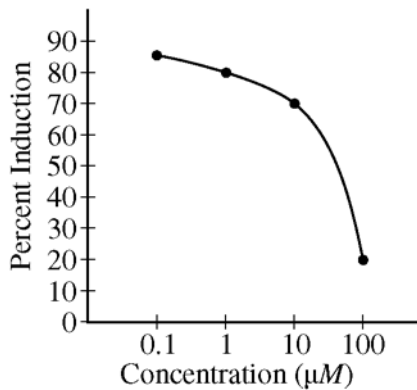

65. Toxicologists say, “the dose makes the poison,” meaning that most substances are harmful in high enough concentrations. The data for anastrozole
- (A) supports this concept because as concentration increases, so does response
 - (B) supports this concept because as concentration increases, response decreases
 - (C) does not support this concept because as concentration increases, response increases
 - (D) does not support this concept because as concentration increases, response decreases
 - (E) does not support this concept because the experiment was not done in animals
66. Based upon the data, what is the best description of this relationship?
- (A) As the concentration of anastrozole increases, the percent induction of breast cancer also increases.
 - (B) As the concentration of anastrozole increases, the percent induction of breast cancer decreases.
 - (C) There is a direct relationship between the concentration of anastrozole and induction of breast cancer.
 - (D) It is more advantageous to be exposed to low amounts of anastrozole.
 - (E) Anastrozole has no effect on breast cancer induction.
67. The development of dangerous strains of disease organisms represents a significant consequence of which of the following agricultural practices?
- (A) Using herbicides in mechanized, large-scale grain farming
 - (B) Using plant-based insecticidal compounds on vegetable crops
 - (C) Growing crops that are genetically modified for increased yields
 - (D) Including the use of legumes into crop-rotation protocols
 - (E) Incorporating antibiotics into the feeding regimens of densely concentrated livestock
68. Important factors that contribute to smog formation in the Los Angeles basin include which of the following?
- I. Ample summer sunshine
 - II. Sea-level elevation
 - III. High concentration of automobiles
- (A) I only
 - (B) III only
 - (C) I and III only
 - (D) II and III only
 - (E) I, II, and III
69. Particulates can be removed from smokestack emissions by which of the following methods?
- (A) Irradiation by UV light
 - (B) Electrostatic precipitators
 - (C) Catalytic converters
 - (D) Liquid chromatography
 - (E) Exhaust-stream aeration
70. Which of the following is the best example of a keystone species?
- (A) Sea otter
 - (B) Sea urchin
 - (C) Spotted owl
 - (D) Snail darter
 - (E) Condor
71. Which of the following are direct products of the use of hydrocarbon fuels in automobile engines?
- (A) O, N, and CO
 - (B) CO, Ar, and O₃
 - (C) CO₂, H₂O, and O₃
 - (D) CO₂, O₃, and Pb
 - (E) CO₂, NO_x, and VOCs

GO ON TO THE NEXT PAGE.

72. Which of the following best explains why more contaminants are leached when solid waste is crushed into small particles and put in contact with water than when the particles are large?
- (A) Larger particles have greater density per unit weight.
 - (B) Water penetrates larger particles more easily than smaller particles.
 - (C) Internal pressure is greater in smaller particles than in larger particles.
 - (D) Smaller particles have a larger surface area per unit volume than larger particles.
 - (E) The contaminant concentration gradient between particle interior and surface is greater for smaller particles.
73. Which of the following is the current recommendation of Congress for the permanent storage of high-level radioactive waste in the United States?
- (A) Burial deep underground at sites remote from population centers
 - (B) Storage in huge pools of water at the nuclear plants where they are produced
 - (C) Storage in concrete and steel casks, above ground in air-cooled buildings, at nuclear plants where they are produced
 - (D) Storage deep in the Antarctic ice sheet and burial beneath the ocean floor
 - (E) Injection deep underground in remote areas between impervious layers of shale and clay
74. Which of the following has the largest proven coal reserves?
- (A) South America
 - (B) The United States
 - (C) Australia
 - (D) Indonesia
 - (E) Africa
75. Which of the following is generally true of *K*-strategist species as compared to *r*-strategist species?
- (A) They reach sexual maturity earlier.
 - (B) They have more young.
 - (C) They are more likely to be invasive species.
 - (D) They have longer life spans.
 - (E) Their population cycles are more rapid.
76. Which of the following is the greatest component (by weight) of municipal solid waste in the United States?
- (A) Paper
 - (B) Yard waste
 - (C) Plastics
 - (D) Glass
 - (E) Food
77. Of the following, which is the primary method of waste disposal in the United States?
- (A) Incineration
 - (B) Landfilling
 - (C) Composting
 - (D) Recycling
 - (E) Ocean dumping
78. Which of the following is the best illustration of the tragedy of the commons?
- (A) Depletion of fishing stocks in the North Atlantic
 - (B) Collective farming of wine grapes in communities in France
 - (C) Using national forests for wood production and harvesting
 - (D) Allocation of all nuclear wastes to one site in Nevada
 - (E) Agreements among western ranchers to jointly manage common grazing land
79. Which of the following lakes contains approximately 20 percent of the world's freshwater?
- (A) Lake Chad
 - (B) Lake Titicaca
 - (C) Lake Tahoe
 - (D) Lake Baikal
 - (E) Lake Superior
80. In Mediterranean climate regions like portions of California, a wetter-than-normal winter often leads to greater severity of fires the following summer. This seeming paradox occurs because increased rain leads to
- (A) greater accumulation of chaparral biomass
 - (B) higher pollination rates of annual flowers
 - (C) greater recreational use of parklands
 - (D) greater erosion and damage of access roads
 - (E) decreased summer rainfall

GO ON TO THE NEXT PAGE.

81. The largest area of old-growth forest in the United States is located in
- (A) Alaska
 - (B) Montana
 - (C) California
 - (D) North Carolina
 - (E) Michigan
82. Which of the following is the zone of a pond or lake in which rooted, emergent plants such as cattails and rushes are located?
- (A) Benthic
 - (B) Limnetic
 - (C) Littoral
 - (D) Profundal
 - (E) Riparian
83. Which of the following has most directly resulted in increased skin cancer rates in Australia?
- (A) Water pollution in the Antarctic Ocean
 - (B) Ozone depletion in the stratosphere
 - (C) Increased immigration of Asian people into Australia
 - (D) The occurrence of a solar maximum
 - (E) Global warming in the lower atmosphere
84. Population biologists are concerned about introduced species such as the zebra mussel in North America because
- (A) their removal from their native habitat has a negative impact
 - (B) predators of the introduced species often overpopulate because of the influx of the introduced species
 - (C) the introduced species compete for resources more effectively than native species
 - (D) introduced species often become endangered when they are placed in a new habitat
 - (E) their introduction will require more land to be protected
85. It has recently been estimated that the growth in world population has slowed in the past decade. Despite this trend, environmentalists remain concerned about the environmental impact of world population, principally because
- (A) the standard of living is increasing in many developing countries, leading to an increased per capita use of natural resources
 - (B) people are living longer in developed nations, putting a strain on the economies of those countries
 - (C) life expectancy is still decreasing in Africa due to AIDS
 - (D) the standard of living is poor in many developing countries, leading to a great deal of deprivation and suffering
 - (E) fertility is falling due to exposure to endocrine disruptors released into the environment
86. The country of Sudan has an estimated annual growth rate of 2 percent. At this rate of growth, approximately how many years will it take for the population of Sudan to double?
- (A) 30 years
 - (B) 35 years
 - (C) 50 years
 - (D) 80 years
 - (E) 140 years
87. Waste from which of the following is an example of nonpoint source pollution?
- (A) Overflow from a sewage treatment plant
 - (B) Outgassing from a municipal landfill
 - (C) Dumping at a food-processing plant
 - (D) Drainage from an abandoned mine
 - (E) Runoff from agricultural fields
88. Which of the following laws gave the EPA the authority to control hazardous waste from “cradle-to-grave”, including the generation, transportation, treatment, storage, and disposal of hazardous waste?
- (A) Resource Conservation and Recovery Act (RCRA)
 - (B) Endangered Species Act (ESA)
 - (C) Comprehensive Environmental Response, Compensation, and Liability Act (CERCLA)
 - (D) National Environmental Policy Act (NEPA)
 - (E) Pollution Prevention Act (PPA)

GO ON TO THE NEXT PAGE.

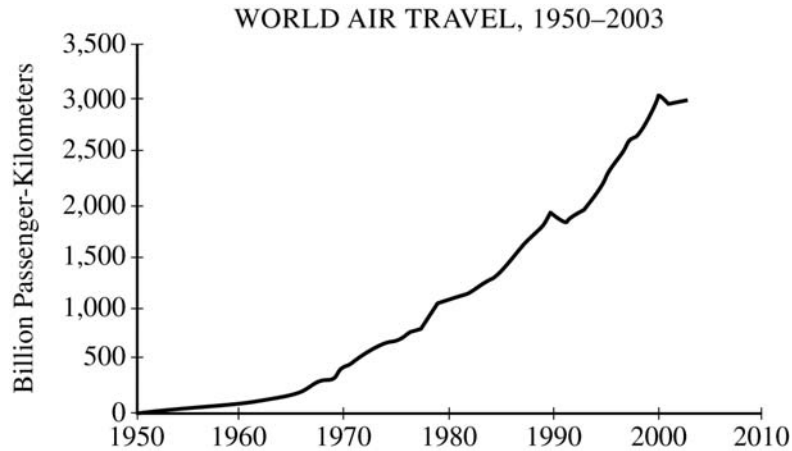

89. Of the phenomena that correlate with the data above, the one that is the most direct consequence of the trend in air travel is
- (A) the increase in the spread of infectious diseases
 - (B) the increase in urban sprawl
 - (C) the decrease in biodiversity
 - (D) the increase in hypoxic aquatic ecosystems
 - (E) the decrease in the total fertility rate of developed nations
-

90. A field is abandoned, and an invasive plant that can live in nutrient-poor soil moves into the field. If the land is later cleared of this invasive species and it is discovered that the soil has an abundance of nitrogen compounds, what conclusion can best be made?
- (A) The plants used up all of the phosphorus and potassium and left the nitrogen behind.
 - (B) Primary succession always produces an abundance of nitrogen.
 - (C) Bacteria in soil and in root nodules converted free nitrogen into nitrogen compounds.
 - (D) The plants were able to produce nitrogen in their leaves.
 - (E) More rock was weathered and broken down to release nitrogen compounds.

91. If an area was originally forested and then underwent urban development, which of the following shows the most likely effects on various parts of the water cycle in the area?

(Note: ↑ represents an increase; ↓ represents a decrease)

	Evaporation and Transpiration	Runoff	Groundwater Recharge
(A)	↓	↑	↓
(B)	↓	↑	↑
(C)	↓	↓	↓
(D)	↑	↑	↓
(E)	↑	↓	↓

92. Between 1960 and 1970, world oil consumption approximately doubled. Which of the following explanations is consistent with this increase?

- (A) The number of passengers per car increased.
- (B) People drove less, conserving gasoline.
- (C) The price of gasoline increased.
- (D) The number of cars on the road increased.
- (E) Cars that were more fuel-efficient were manufactured.

93. Which of the following practices is consistent with the production of organic crops according to the United States Department of Agriculture?

- (A) Using sodium nitrate as a fertilizer on green, leafy vegetables
- (B) Using strychnine to prevent buildup of aphid populations in field crops
- (C) Using chemicals known as pheromones to disrupt insect mating cycles
- (D) Using sewage sludge to improve the fertility and structure of soil
- (E) Using genetically modified plant varieties that kill insects that chew their leaves

94. Which of the following best describes the process known as “mountaintop removal”?

- (A) The use of trees planted at high elevations to eliminate carbon dioxide from the atmosphere
- (B) The use of heavy equipment to move overburden downhill during the strip mining of coal
- (C) The placement of hazardous-waste disposal sites at high elevations in mountainous regions
- (D) The shearing away of undersea mountain peaks to improve shipping lanes
- (E) The reduction of glacial ice resulting from increased global temperatures

GO ON TO THE NEXT PAGE.

95. Vegetarianism is often cited as a partial solution to the growing problem of deforestation and other types of habitat destruction as the human population continues to grow. The reason for this is
- (A) vegetarians are healthier due to a lack of animal fat in their diets
 - (B) more people can be fed using less agricultural land because vegetarians eat at a lower trophic level
 - (C) vegetarians consume fewer calories per person and therefore require fewer acres of farmland
 - (D) vegetarian diets often recommend consuming large amounts of tree nuts as a source of protein, which preserves forest habitats
 - (E) vegetarians often support conservation efforts that promote forest conservation
96. Although the use of DDT was banned in the United States in 1972, a test of the body tissue of an average United States resident today would most likely reveal the presence of DDT because
- (A) DDT is the breakdown product of some newer pesticides on the market
 - (B) DDT is water soluble
 - (C) other countries that export produce to the United States still use DDT
 - (D) many farmers in the United States are still using DDT illegally
 - (E) DDT is naturally produced by many plants
97. Which of the following is part of a positive feedback mechanism associated with global climate change?
- (A) Increased gas mileage in cars
 - (B) Increased cloudiness caused by more moisture in the atmosphere
 - (C) Melting of Arctic sea ice
 - (D) Increased acidity of seawater
 - (E) Increased growth of CO₂-absorbing trees and grasses

Questions 98-100

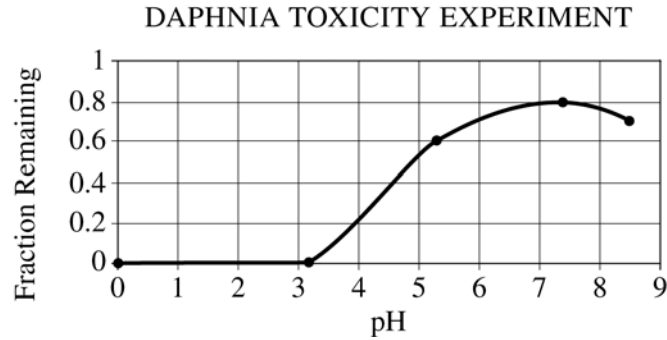

DAPHNIA TOXICITY EXPERIMENT

pH	Daphnia Remaining After Two Hours	Fraction of Daphnia Remaining
0	0	0
3.2	0	0
5.3	24	0.6
7.4	32	0.8
8.5	28	0.7

The data shown were collected in a laboratory experiment in which the effect of pH on the survival of water fleas (*Daphnia pulex*) was examined. In each trial, 40 live water fleas were added to a solution with the pH as indicated. After two hours, observations were made to determine the number of fleas remaining alive in the sample. Results are presented in the table and in graphical form above.

98. The pH at which 50 percent of the *Daphnia* survive after 2 hours of exposure can be predicted from the data. This pH is closest to
- (A) 2.5
 - (B) 3.5
 - (C) 4.5
 - (D) 7.5
 - (E) 8.5
99. How would including a control group be useful in this experiment?
- (A) It would provide a reference for the effects of random environmental factors.
 - (B) It would provide a number against which percentages can be computed.
 - (C) It would provide a value for which the standard pH can be measured.
 - (D) It would provide a standard number to test for statistical uncertainty.
 - (E) It would provide an end data point for graphical analysis.
100. On the basis of the data, the best prediction of the pH of the water in which *Daphnia* normally are found in the wild is
- (A) 1
 - (B) 3
 - (C) 5
 - (D) 7
 - (E) 9

GO ON TO THE NEXT PAGE.

END OF SECTION I
IF YOU FINISH BEFORE TIME IS CALLED,
YOU MAY CHECK YOUR WORK ON THIS SECTION.

DO NOT GO ON TO SECTION II UNTIL YOU ARE TOLD TO DO SO.

Section II

Free-Response Questions

ENVIRONMENTAL SCIENCE

SECTION II

Time—90 minutes

4 Questions

Directions: Answer all four questions, which are weighted equally; the suggested time is about 22 minutes for answering each question. Where calculations are required, clearly show how you arrived at your answer. Where explanation or discussion is required, support your answers with relevant information and/or specific examples.

1. Read the following article from the *Fremont Examiner* and answer the questions that follow.

MUNICIPAL SOLID WASTE THREATENS FREMONT WOOD TURTLE

At a recent meeting of the Fremont City Council, supporters of the rare Fremont wood turtle clashed with representatives of the Fremont Planning Board. Speaking for the Planning Board, Dr. David Loxsom explained to the 250 Fremont residents in attendance that the city needs to convert some of its woodlands to a landfill. Dr. Loxsom provided the diagram reproduced at the right, showing the urbanized northern tier of Fremont, State Highway 123, and three tracts of wooded municipal land south of the city (labeled Tract A, Tract B, and Tract C). According to Dr. Loxsom, the city currently trucks its municipal solid waste to a privately owned dump located about 50 miles north of the city. One-third of the city sanitation budget is spent on dumping fees and trucking costs associated with using this private dump.

Dr. Frederick Hong of the Save Our Wood Turtle Alliance spoke next. He opposed the destruction of any of the municipal land in south Fremont because each tract is suitable turtle habitat. Several other residents spoke about the landfill and the turtle. As the *Examiner*

went to press, there was consensus for building a landfill on one tract and setting aside the other two tracts to protect the turtle's habitat, but no agreement had been reached as to which land should be preserved.

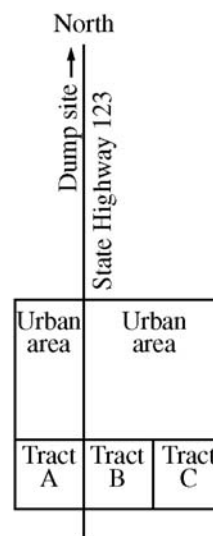

- Discuss ONE environmental benefit and ONE economic benefit to the city of Fremont that would result from Fremont having its own sanitary landfill within its city limits.
- Discuss TWO practical methods of maximizing the effectiveness, safety, and aesthetic appeal of the new sanitary landfill.
- Assuming that a landfill will be developed within city limits, indicate which tract (A, B, or C) should be the site of the landfill. The two remaining tracts will be preserved for turtle habitat. Provide ONE economic justification for your choice and ONE environmental justification for your choice.
- Identify ONE United States law or international treaty that could apply to this land-use decision, and explain how the law or treaty could be applied.

GO ON TO THE NEXT PAGE.

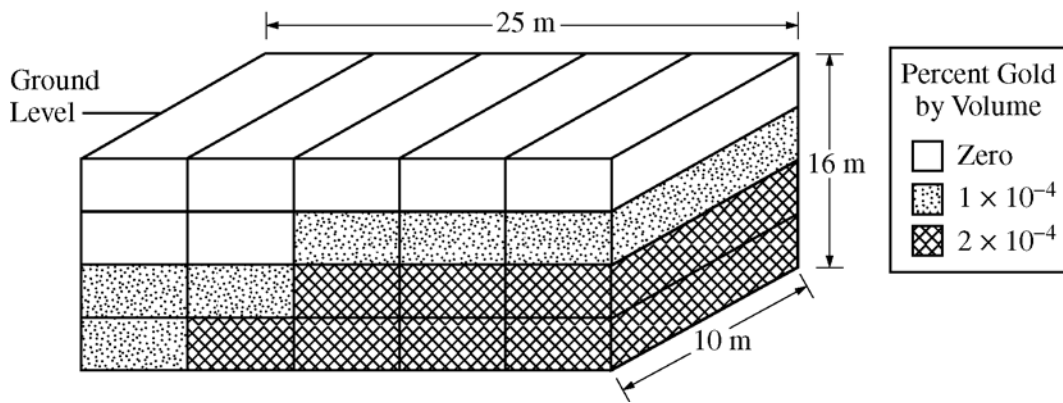

2. Auric Miners, Inc., won a contract to mine gold from the terrain represented in the diagram above. The terrain can be divided into 20 rectangular blocks, each with a volume of 200 cubic meters. Site analysis has revealed the average gold content of each block, as designated by the different patterns shown in the legend.
- Calculate the volume of gold, in cubic meters, that can be mined from the excavation of all 20 blocks. Show all work.
 - Calculate the percent of gold in the total excavation. Show all work.
 - If the total cost of excavating and extracting the gold is \$1,520,000, calculate the price that the gold must be sold for, in dollars per gram, in order for the mine to break even. (The density of gold is 19 g/cm^3 .)
 - Describe TWO potential uses for the mine waste that will be produced during the extraction of the gold from the excavated material.
 - Describe TWO environmental problems that are likely to develop at the mine site after the gold has been extracted and the mine is abandoned.

GO ON TO THE NEXT PAGE.

3. Studies indicate that between the present and 2050, substantial growth in population and energy consumption will occur both in less developed countries (LDCs) like India and China and in more developed countries (MDCs) like the United States and Japan. The table below displays these projections.

	Present	2050
Total Population: LDCs	5.1×10^9	7.8×10^9
Total Population: MDCs	1.2×10^9	1.3×10^9
Total Energy Consumption: LDCs	1.3×10^{17} Btu	5.2×10^{17} Btu
Total Energy Consumption: MDCs	2.5×10^{17} Btu	3.0×10^{17} Btu

- (a) Describe TWO current social conditions that support the prediction that most population growth will occur in LDCs between now and 2050.
- (b) Calculate the percent increase in
- total energy consumption by LDCs between the present and 2050
 - total energy consumption by MDCs between the present and 2050
- (c) Describe TWO reasons why the percent change in total energy consumption by LDCs is projected to be so different from the percent change in total energy consumption by MDCs.
- (d) Describe the process by which fossil fuels are used to provide electrical energy.
- (e) The increase in the global energy demand is expected to outstrip the energy available from the burning of fossil fuels. Describe TWO sustainable methods of energy production that can make a significant contribution toward meeting the future global energy demand.
4. Matter is continually recycled between the biotic and abiotic components of Earth's ecosystems in biogeochemical cycles. The various cycles differ from one another in several key aspects of their storage, conversion, and modes of transport.
- (a) Describe the critical processes by which nitrogen is cycled through the biotic and abiotic components of Earth's ecosystems and identify the primary storage sink for nitrogen.
- (b) Explain ONE major way in which the phosphorus cycle differs from the nitrogen cycle.
- (c) Identify EITHER one nitrogen compound OR one phosphorus compound that is considered a pollutant when released by human activity into the environment. For the compound you identified, describe the human activity and a specific environmental problem that results.
- (d) Describe ONE way in which humans have disrupted the natural cycling of carbon and TWO major environmental consequences of that disruption.

STOP

END OF EXAM

Name: _____

AP[®] Environmental Science
Student Answer Sheet for Multiple-Choice Section

No.	Answer
1	
2	
3	
4	
5	
6	
7	
8	
9	
10	
11	
12	
13	
14	
15	
16	
17	
18	
19	
20	
21	
22	
23	
24	
25	
26	
27	
28	
29	
30	

No.	Answer
31	
32	
33	
34	
35	
36	
37	
38	
39	
40	
41	
42	
43	
44	
45	
46	
47	
48	
49	
50	
51	
52	
53	
54	
55	
56	
57	
58	
59	
60	

No.	Answer
61	
62	
63	
64	
65	
66	
67	
68	
69	
70	
71	
72	
73	
74	
75	
76	
77	
78	
79	
80	
81	
82	
83	
84	
85	
86	
87	
88	
89	
90	

No.	Answer
91	
92	
93	
94	
95	
96	
97	
98	
99	
100	

**AP[®] Environmental Science
Multiple-Choice Answer Key**

No.	Correct Answer
1	D
2	E
3	D
4	A
5	E
6	D
7	B
8	E
9	D
10	A
11	B
12	A
13	A
14	E
15	A
16	E
17	B
18	B
19	C
20	E
21	E
22	D
23	E
24	B
25	B
26	E
27	E
28	C
29	C
30	B

No.	Correct Answer
31	E
32	A
33	C
34	A
35	C
36	D
37	D
38	D
39	A
40	C
41	E
42	B
43	C
44	C
45	E
46	B
47	A
48	E
49	D
50	C
51	E
52	B
53	A
54	D
55	D
56	B
57	B
58	D
59	C
60	A

No.	Correct Answer
61	C
62	C
63	E
64	E
65	D
66	B
67	E
68	C
69	B
70	A
71	E
72	D
73	A
74	B
75	D
76	A
77	B
78	A
79	D
80	A
81	A
82	C
83	B
84	C
85	A
86	B
87	E
88	A
89	A
90	C

No.	Correct Answer
91	A
92	D
93	C
94	B
95	B
96	C
97	C
98	C
99	A
100	D

AP[®] Environmental Science
Free-Response Scoring Guidelines

Question 1

- (a) One point is earned for an acceptable environmental benefit including, but not limited to, the following.
- Less pollution produced from transporting waste (separate from fuel *cost*).
 - Fremont can apply its own stringent standards for design and maintenance of landfill.
 - Can start from scratch—building a state-of-the-art landfill with emphasis on educating Fremont residents about recycling, reduction, and reuse.
 - Less chance of leakage during transport.

One point is earned for an acceptable economic benefit including, but not limited to, the following.

- Lower fuel costs for transporting waste.
- Avoids costly dumping (tipping) fees.
- Opportunity to capture methane for municipal use.
- Opportunity to burn solid waste for generation of electricity.
- Provides jobs for Fremont residents to work at landfill and recycling center.

- (b) One point is earned for each of two acceptable methods including, but not limited to, the following.
- Securely fenced to prevent trespassing and/or illegal dumping.
 - Covered daily with sufficient clean fill to reduce odor and pests.
 - Vent for methane exhaust.
 - Located a safe distance from streams/aquifers.
 - Lined with impermeable clay (and/or multiple poly/clay) layer to prevent leachate from exiting landfill/polluting ground water.
 - Peripheral monitoring wells to ensure safety of groundwater.
 - Treed buffer zone to minimize negative visual impact.
 - Leachate collected and treated on site.

- (c) Two points are earned for indicating that the site for the landfill should be tract A. One additional point is earned for an appropriate economic justification (such as necessary access roads can be shorter, reduced employee work hours due to shortened waste transport distance), and a second additional point is earned for an appropriate environmental justification (such as not fragmenting turtle habitat) and/or minimizing turtle/vehicle collisions.

One point is earned for indicating that the site for the landfill should be tract C. One additional point is earned for an appropriate economic justification (such as tract C is less valuable land because it has no road frontage), and a second additional point is earned for an appropriate environmental justification (such as keeping preserve unfragmented by building fences and under-highway corridors for turtle movement between tracts).

No point is earned for indicating that the site for the landfill should be tract B; however, 1 point can be earned for an appropriate economic justification (such as necessary access roads can be shorter), and a second point can be earned for appropriate environmental justification (such as maintenance of two breeding populations in case of a catastrophic loss of one of the populations).

- (d) One point is earned for identification of a relevant law or treaty (such as Endangered Species Act, Clean Water Act, Clean Air Act, RCRA), and 1 point is earned for explaining how the act applies to this situation.

AP[®] Environmental Science
Free-Response Scoring Guidelines

Question 2

- (a) One point is earned for an appropriate setup and a second point for the correct answer.
(Two example solutions are shown below.)

$$\begin{aligned} & 7 \text{ blocks} \times \frac{200 \text{ m}^3}{1 \text{ block}} \times (2 \times 10^{-4} \% \text{ gold}) + 7 \text{ blocks} \times \frac{200 \text{ m}^3}{1 \text{ block}} \times (0 \% \text{ gold}) + 6 \text{ blocks} \times \frac{200 \text{ m}^3}{1 \text{ block}} \times (1 \times 10^{-4} \% \text{ gold}) \\ & = 1,400 \text{ m}^3 \times (2 \times 10^{-6} \text{ gold}) + 1,400 \text{ m}^3 \times 0 + 1,200 \text{ m}^3 \times (1 \times 10^{-6} \text{ gold}) \\ & = (2.8 \times 10^{-3}) \text{ m}^3 \text{ gold} + 0 + (1.2 \times 10^{-3}) \text{ m}^3 \text{ gold} = 4.0 \times 10^{-3} \text{ m}^3 \text{ gold} \end{aligned}$$

OR

$$\begin{aligned} \text{avg. \% gold} &= \frac{7 \text{ blocks} \times (2 \times 10^{-4} \%) + 7 \text{ blocks} \times (0 \%) + 6 \text{ blocks} \times (1 \times 10^{-4} \%)}{20 \text{ blocks}} = 1.0 \times 10^{-4} \% \text{ gold} \\ \text{total volume} &= (25 \times 16 \times 10) \text{ m}^3 = 4,000 \text{ m}^3 \\ \text{volume of gold} &= 4,000 \text{ m}^3 \times (1.0 \times 10^{-4} \%) \text{ gold} = 4.0 \times 10^{-3} \text{ m}^3 \text{ gold} \end{aligned}$$

- (b) One point is earned for an appropriate setup and a second point for the correct answer.

$$\text{avg. \% gold} = \frac{7 \text{ blocks} \times (2 \times 10^{-4} \%) + 7 \text{ blocks} \times (0 \%) + 6 \text{ blocks} \times (1 \times 10^{-4} \%)}{20 \text{ blocks}} = 1.0 \times 10^{-4} \% \text{ gold}$$

OR

$$\text{percent gold in total excavation} = \frac{4.0 \times 10^{-3} \text{ m}^3 \text{ gold}}{4,000 \text{ m}^3 \text{ total volume}} \times 100\% = 1 \times 10^{-4} \%$$

- (c) One point is earned for an appropriate setup and a second point for the correct answer.

$$\begin{aligned} \text{mass of gold} &= 4 \times 10^{-3} \text{ m}^3 \text{ gold} \times \frac{10^6 \text{ cm}^3}{1 \text{ m}^3} \times \frac{19 \text{ g gold}}{1 \text{ cm}^3 \text{ gold}} = 76 \times 10^3 \text{ g gold} = 7.6 \times 10^4 \text{ g gold} \\ \text{cost of gold extraction} &= \frac{\$ 1,520,000}{7.6 \times 10^4 \text{ g}} = \$ 20 \text{ per gram} = \text{break even price} \end{aligned}$$

- (d) One point is earned for each of two potential uses for the mine waste (such as in concrete for buildings, as fill for road grading, for extraction of additional minerals that may be present). One additional elaboration point may be earned for a more detailed description of potential uses (such as specifying use of fill for necessary mine access roads, or identification of the minerals associated with gold deposits).

AP[®] Environmental Science
Free-Response Scoring Guidelines

Question 2 (continued)

- (e) One point is earned for each of two environmental problems associated with abandoned mines (such as lack of topsoil for regrowth of vegetation, contamination of groundwater by mine leachate, disruption of water drainage patterns, habitat destruction/fragmentation, community destabilization [secondary succession], unsightly tailings of mining process [loss of aesthetic beauty]).

One additional elaboration point may be earned for a more detailed description of potential environmental problems (such as identity of toxins like cyanide, often associated with gold mining, or explanation of the chemistry of acid mine drainage) or an overall description of the strip-mine reclamation process.

AP[®] Environmental Science
Free-Response Scoring Guidelines

Question 3

- (a) One point is earned for each of two social conditions including, but not limited to, the following.
- Large families are needed to provide agricultural workers.
 - Large families are needed to ensure security of elders (no government social networks).
 - High fertility rate is a reaction to high infant mortality.
 - Low education and limited access to family planning for women.
 - Fewer economic opportunities for women.
 - Population is less urbanized in LDCs.
 - Population contains a higher percentage of women of reproductive age.

One additional elaboration point may be earned for a more detailed description of social conditions in particular countries.

- (b)(i) One point is earned for an appropriate setup and a second point for the correct answer.

$$5.2 \times 10^{17} \text{ BTU} - 1.3 \times 10^{17} \text{ BTU} = 3.9 \times 10^{17} \text{ BTU increase}$$

$$\frac{3.0 \times 10^{17} \text{ BTU}}{1.3 \times 10^{17} \text{ BTU}} \times 100\% = 300\% \text{ increase}$$

- (b)(ii) One point is earned for an appropriate setup and a second point for the correct answer.

$$3.0 \times 10^{17} \text{ BTU} - 2.5 \times 10^{17} \text{ BTU} = 0.5 \times 10^{17} \text{ BTU increase}$$

$$\frac{0.5 \times 10^{17} \text{ BTU}}{2.5 \times 10^{17} \text{ BTU}} \times 100\% = 20\% \text{ increase}$$

- (c) One point is earned for identifying that the standard of living is increasing. By 2050, MDCs may increasingly use energy-conservation technologies. Also, energy-conservation incentives and the price of energy will likely cause decreased consumption in MDCs.

One point is earned for identifying faster growth of population in LDCs.

- (d) Up to 3 points can be earned, 1 each for the following steps.
- 1) Fuel is burned.
 - 2) Water is heated to steam.
 - 3) Steam pushes turbine blades.
 - 4) Spinning turbines rotate coils through magnetic field in generators.
 - 5) Current is induced in coils as they spin, producing electrical energy.

AP[®] Environmental Science
Free-Response Scoring Guidelines

Question 3 (continued)

- (e) One point is earned for each of two sustainable methods including, but not limited to, the following.
- Windmill-driven generators.
 - Use of sustainably produced biomass such as switch grass, algae.
 - Greater use of geothermal/heat pumps.
 - Tidal power or wave-generated power.
 - Photovoltaic cells.
 - Passive solar for heating buildings.
 - Hydroelectric.

One additional elaboration point may be earned for a more detailed description of a sustainable method of energy generation.

**AP[®] Environmental Science
Free-Response Scoring Guidelines**

Question 4

- (a) One point is earned for identification of atmosphere as the primary sink for nitrogen, N_2 .

Up to 3 more points can be earned, 1 each for the following steps.

- 1) Atmospheric nitrogen is fixed by bacteria in soil and in root nodules to produce ammonia/ammonium (some by lightning).
- 2) Ammonia is oxidized in soil by nitrifying bacteria to nitrites and then to nitrates.
- 3) Plants take up soluble nitrogen compounds through roots.
- 4) In plants, nitrogen compounds are used to produce biochemicals like protein, DNA, chlorophyll.
- 5) Denitrifying bacteria break down nitrogen compounds in the process of decomposition and release elemental nitrogen back into the atmosphere; or nitrifying decomposers break down organic nitrogen compounds, making them available to plants again in the form of nitrates.

- (b) One point is earned for explaining that the phosphorus cycle does not involve any gaseous P compounds, or that the major sink in the phosphorus cycle is the lithosphere, or that bacteria are not as pivotal in the phosphorus cycle as they are in the nitrogen cycle.

- (c) One point is earned for identification of one N or one P compound (such as nitrates in commercial fertilizers or phosphates in cleaning agents).

One point is earned for a description of a human activity that results in the release of the compound (such as application of fertilizer in farming and subsequent runoff, or release of gray water from improper wastewater treatment or cleaning operations).

One point is earned for describing a specific environmental problem that results from the release of the identified compound (such as altered DO, cultural eutrophication, dead zones).

- (d) One point is earned for identifying one disruption caused by humans (such as burning of fossil fuels, deforestation/slash and burn).

One point each is earned for two environmental consequences of the disruption (such as global warming, increased rates of photosynthesis, ocean acidification, sea-level rise, and weather disruptions resulting from global warming—for example, flooding, drought, heat waves, intensification of storms).

Note: No points are earned for acid rain or any other noncarbon-related environmental problems.

One additional elaboration point may be earned for a more detailed description of a sustainable method.