



PUZZLER

This one-bottle wine holder is an interesting example of a mechanical system that seems to defy gravity. The system (holder plus bottle) is balanced when its center of gravity is directly over the lowest support point. What two conditions are necessary for an object to exhibit this kind of stability? (Charles D. Winters)

Static Equilibrium and Elasticity

chapter

12

Chapter Outline

- 12.1** The Conditions for Equilibrium
- 12.2** More on the Center of Gravity
- 12.3** Examples of Rigid Objects in Static Equilibrium

- 12.4** Elastic Properties of Solids

In Chapters 10 and 11 we studied the dynamics of rigid objects—that is, objects whose parts remain at a fixed separation with respect to each other when subjected to external forces. Part of this chapter addresses the conditions under which a rigid object is in equilibrium. The term *equilibrium* implies either that the object is at rest or that its center of mass moves with constant velocity. We deal here only with the former case, in which the object is described as being in *static equilibrium*. Static equilibrium represents a common situation in engineering practice, and the principles it involves are of special interest to civil engineers, architects, and mechanical engineers. If you are an engineering student you will undoubtedly take an advanced course in statics in the future.

The last section of this chapter deals with how objects deform under load conditions. Such deformations are usually elastic and do not affect the conditions for equilibrium. An *elastic* object returns to its original shape when the deforming forces are removed. Several elastic constants are defined, each corresponding to a different type of deformation.

12.1 THE CONDITIONS FOR EQUILIBRIUM

In Chapter 5 we stated that one necessary condition for equilibrium is that the net force acting on an object be zero. If the object is treated as a particle, then this is the only condition that must be satisfied for equilibrium. The situation with real (extended) objects is more complex, however, because these objects cannot be treated as particles. For an extended object to be in static equilibrium, a second condition must be satisfied. This second condition involves the net torque acting on the extended object. Note that equilibrium does not require the absence of motion. For example, a rotating object can have constant angular velocity and still be in equilibrium.

Consider a single force \mathbf{F} acting on a rigid object, as shown in Figure 12.1. The effect of the force depends on its point of application P . If \mathbf{r} is the position vector of this point relative to O , the torque associated with the force \mathbf{F} about O is given by Equation 11.7:

$$\boldsymbol{\tau} = \mathbf{r} \times \mathbf{F}$$

Recall from the discussion of the vector product in Section 11.2 that the vector $\boldsymbol{\tau}$ is perpendicular to the plane formed by \mathbf{r} and \mathbf{F} . You can use the right-hand rule to determine the direction of $\boldsymbol{\tau}$: Curl the fingers of your right hand in the direction of rotation that \mathbf{F} tends to cause about an axis through O ; your thumb then points in the direction of $\boldsymbol{\tau}$. Hence, in Figure 12.1 $\boldsymbol{\tau}$ is directed toward you out of the page.

As you can see from Figure 12.1, the tendency of \mathbf{F} to rotate the object about an axis through O depends on the moment arm d , as well as on the magnitude of \mathbf{F} . Recall that the magnitude of $\boldsymbol{\tau}$ is Fd (see Eq. 10.19). Now suppose a rigid object is acted on first by force \mathbf{F}_1 and later by force \mathbf{F}_2 . If the two forces have the same magnitude, they will produce the same effect on the object only if they have the same direction and the same line of action. In other words,

two forces \mathbf{F}_1 and \mathbf{F}_2 are **equivalent** if and only if $F_1 = F_2$ and if and only if the two produce the same torque about any axis.

The two forces shown in Figure 12.2 are equal in magnitude and opposite in direction. They are *not* equivalent. The force directed to the right tends to rotate

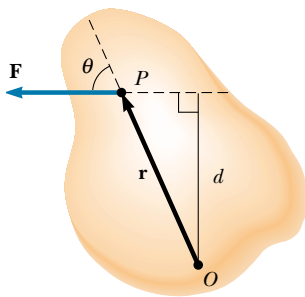

Figure 12.1 A single force \mathbf{F} acts on a rigid object at the point P .

Equivalent forces

the object clockwise about an axis perpendicular to the diagram through O , whereas the force directed to the left tends to rotate it counterclockwise about that axis.

Suppose an object is pivoted about an axis through its center of mass, as shown in Figure 12.3. Two forces of equal magnitude act in opposite directions along parallel lines of action. A pair of forces acting in this manner form what is called a **couple**. (The two forces shown in Figure 12.2 also form a couple.) Do not make the mistake of thinking that the forces in a couple are a result of Newton's third law. They cannot be third-law forces because they act on the same object. Third-law force pairs act on different objects. Because each force produces the same torque Fd , the net torque has a magnitude of $2Fd$. Clearly, the object rotates clockwise and undergoes an angular acceleration about the axis. With respect to rotational motion, this is a nonequilibrium situation. The net torque on the object gives rise to an angular acceleration α according to the relationship $\Sigma\tau = 2Fd = I\alpha$ (see Eq. 10.21).

In general, an object is in rotational equilibrium only if its angular acceleration $\alpha = 0$. Because $\Sigma\tau = I\alpha$ for rotation about a fixed axis, our second necessary condition for equilibrium is that **the net torque about any axis must be zero**. We now have two necessary conditions for equilibrium of an object:

1. The resultant external force must equal zero. $\Sigma\mathbf{F} = 0$ (12.1)

2. The resultant external torque about *any* axis must be zero. $\Sigma\tau = 0$ (12.2)

The first condition is a statement of translational equilibrium; it tells us that the linear acceleration of the center of mass of the object must be zero when viewed from an inertial reference frame. The second condition is a statement of rotational equilibrium and tells us that the angular acceleration about any axis must be zero. In the special case of **static equilibrium**, which is the main subject of this chapter, the object is at rest and so has no linear or angular speed (that is, $v_{\text{CM}} = 0$ and $\omega = 0$).

Quick Quiz 12.1

(a) Is it possible for a situation to exist in which Equation 12.1 is satisfied while Equation 12.2 is not? (b) Can Equation 12.2 be satisfied while Equation 12.1 is not?

The two vector expressions given by Equations 12.1 and 12.2 are equivalent, in general, to six scalar equations: three from the first condition for equilibrium, and three from the second (corresponding to x , y , and z components). Hence, in a complex system involving several forces acting in various directions, you could be faced with solving a set of equations with many unknowns. Here, we restrict our discussion to situations in which all the forces lie in the xy plane. (Forces whose vector representations are in the same plane are said to be *coplanar*.) With this restriction, we must deal with only three scalar equations. Two of these come from balancing the forces in the x and y directions. The third comes from the torque equation—namely, that the net torque about *any* point in the xy plane must be zero. Hence, the two conditions of equilibrium provide the equations

$$\Sigma F_x = 0 \quad \Sigma F_y = 0 \quad \Sigma \tau_z = 0 \quad (12.3)$$

where the axis of the torque equation is arbitrary, as we now show.

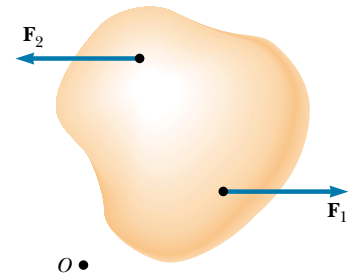

Figure 12.2 The forces \mathbf{F}_1 and \mathbf{F}_2 are not equivalent because they do not produce the same torque about some axis, even though they are equal in magnitude and opposite in direction.

Conditions for equilibrium

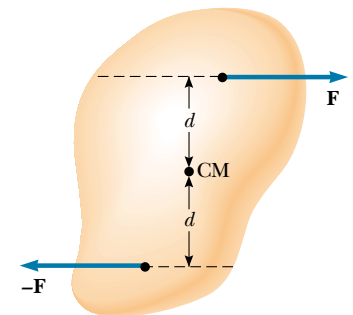

Figure 12.3 Two forces of equal magnitude form a couple if their lines of action are different parallel lines. In this case, the object rotates clockwise. The net torque about any axis is $2Fd$.

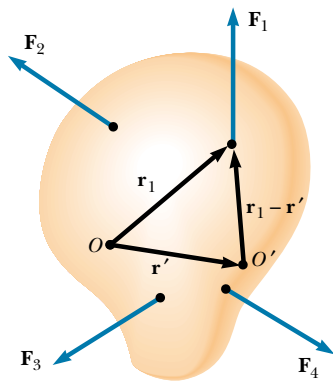

Figure 12.4 Construction showing that if the net torque is zero about origin O , it is also zero about any other origin, such as O' .

Regardless of the number of forces that are acting, if an object is in translational equilibrium and if the net torque is zero about one axis, then the net torque must also be zero about any other axis. The point can be inside or outside the boundaries of the object. Consider an object being acted on by several forces such that the resultant force $\Sigma \mathbf{F} = \mathbf{F}_1 + \mathbf{F}_2 + \mathbf{F}_3 + \dots = 0$. Figure 12.4 describes this situation (for clarity, only four forces are shown). The point of application of \mathbf{F}_1 relative to O is specified by the position vector \mathbf{r}_1 . Similarly, the points of application of $\mathbf{F}_2, \mathbf{F}_3, \dots$ are specified by $\mathbf{r}_2, \mathbf{r}_3, \dots$ (not shown). The net torque about an axis through O is

$$\Sigma \tau_O = \mathbf{r}_1 \times \mathbf{F}_1 + \mathbf{r}_2 \times \mathbf{F}_2 + \mathbf{r}_3 \times \mathbf{F}_3 + \dots$$

Now consider another arbitrary point O' having a position vector \mathbf{r}' relative to O . The point of application of \mathbf{F}_1 relative to O' is identified by the vector $\mathbf{r}_1 - \mathbf{r}'$. Likewise, the point of application of \mathbf{F}_2 relative to O' is $\mathbf{r}_2 - \mathbf{r}'$, and so forth. Therefore, the torque about an axis through O' is

$$\begin{aligned} \Sigma \tau_{O'} &= (\mathbf{r}_1 - \mathbf{r}') \times \mathbf{F}_1 + (\mathbf{r}_2 - \mathbf{r}') \times \mathbf{F}_2 + (\mathbf{r}_3 - \mathbf{r}') \times \mathbf{F}_3 + \dots \\ &= \mathbf{r}_1 \times \mathbf{F}_1 + \mathbf{r}_2 \times \mathbf{F}_2 + \mathbf{r}_3 \times \mathbf{F}_3 + \dots - \mathbf{r}' \times (\mathbf{F}_1 + \mathbf{F}_2 + \mathbf{F}_3 + \dots) \end{aligned}$$

Because the net force is assumed to be zero (given that the object is in translational equilibrium), the last term vanishes, and we see that the torque about O' is equal to the torque about O . Hence, **if an object is in translational equilibrium and the net torque is zero about one point, then the net torque must be zero about any other point.**

12.2 MORE ON THE CENTER OF GRAVITY

We have seen that the point at which a force is applied can be critical in determining how an object responds to that force. For example, two equal-magnitude but oppositely directed forces result in equilibrium if they are applied at the same point on an object. However, if the point of application of one of the forces is moved, so that the two forces no longer act along the same line of action, then a force couple results and the object undergoes an angular acceleration. (This is the situation shown in Figure 12.3.)

Whenever we deal with a rigid object, one of the forces we must consider is the force of gravity acting on it, and we must know the point of application of this force. As we learned in Section 9.6, on every object is a special point called its center of gravity. All the various gravitational forces acting on all the various mass elements of the object are equivalent to a single gravitational force acting through this point. Thus, to compute the torque due to the gravitational force on an object of mass M , we need only consider the force $M\mathbf{g}$ acting at the center of gravity of the object.

How do we find this special point? As we mentioned in Section 9.6, if we assume that \mathbf{g} is uniform over the object, then the center of gravity of the object coincides with its center of mass. To see that this is so, consider an object of arbitrary shape lying in the xy plane, as illustrated in Figure 12.5. Suppose the object is divided into a large number of particles of masses m_1, m_2, m_3, \dots having coordinates $(x_1, y_1), (x_2, y_2), (x_3, y_3), \dots$. In

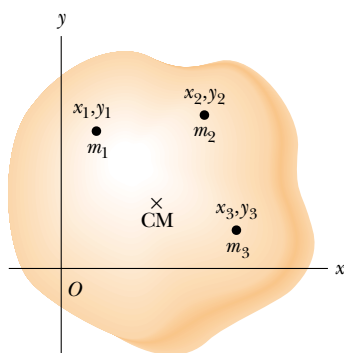

Figure 12.5 An object can be divided into many small particles each having a specific mass and specific coordinates. These particles can be used to locate the center of mass.

Equation 9.28 we defined the x coordinate of the center of mass of such an object to be

$$x_{\text{CM}} = \frac{m_1x_1 + m_2x_2 + m_3x_3 + \cdots}{m_1 + m_2 + m_3 + \cdots} = \frac{\sum_i m_i x_i}{\sum_i m_i}$$

We use a similar equation to define the y coordinate of the center of mass, replacing each x with its y counterpart.

Let us now examine the situation from another point of view by considering the force of gravity exerted on each particle, as shown in Figure 12.6. Each particle contributes a torque about the origin equal in magnitude to the particle's weight $m_i g$ multiplied by its moment arm. For example, the torque due to the force $m_1 \mathbf{g}_1$ is $m_1 g_1 x_1$, where g_1 is the magnitude of the gravitational field at the position of the particle of mass m_1 . We wish to locate the center of gravity, the point at which application of the single gravitational force $M\mathbf{g}$ (where $M = m_1 + m_2 + m_3 + \cdots$ is the total mass of the object) has the same effect on rotation as does the combined effect of all the individual gravitational forces $m_i \mathbf{g}_i$. Equating the torque resulting from $M\mathbf{g}$ acting at the center of gravity to the sum of the torques acting on the individual particles gives

$$(m_1 g_1 + m_2 g_2 + m_3 g_3 + \cdots) x_{\text{CG}} = m_1 g_1 x_1 + m_2 g_2 x_2 + m_3 g_3 x_3 + \cdots$$

This expression accounts for the fact that the gravitational field strength g can in general vary over the object. If we assume uniform g over the object (as is usually the case), then the g terms cancel and we obtain

$$x_{\text{CG}} = \frac{m_1 x_1 + m_2 x_2 + m_3 x_3 + \cdots}{m_1 + m_2 + m_3 + \cdots} \quad (12.4)$$

Comparing this result with Equation 9.28, we see that **the center of gravity is located at the center of mass as long as the object is in a uniform gravitational field.**

In several examples presented in the next section, we are concerned with homogeneous, symmetric objects. The center of gravity for any such object coincides with its geometric center.

12.3 EXAMPLES OF RIGID OBJECTS IN STATIC EQUILIBRIUM

 The photograph of the one-bottle wine holder on the first page of this chapter shows one example of a balanced mechanical system that seems to defy gravity. For the system (wine holder plus bottle) to be in equilibrium, the net external force must be zero (see Eq. 12.1) and the net external torque must be zero (see Eq. 12.2). The second condition can be satisfied only when the center of gravity of the system is directly over the support point.

In working static equilibrium problems, it is important to recognize all the external forces acting on the object. Failure to do so results in an incorrect analysis. When analyzing an object in equilibrium under the action of several external forces, use the following procedure.

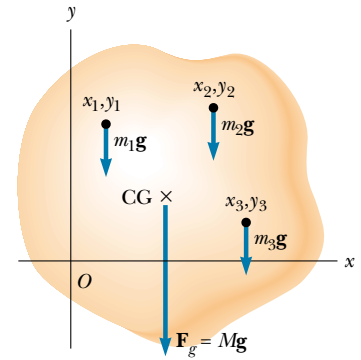
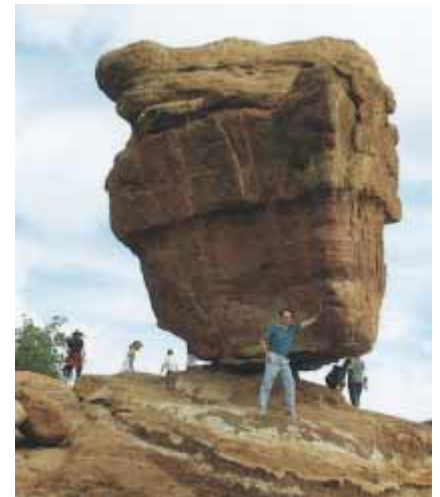

Figure 12.6 The center of gravity of an object is located at the center of mass if \mathbf{g} is constant over the object.



A large balanced rock at the Garden of the Gods in Colorado Springs, Colorado—an example of stable equilibrium.

Problem-Solving Hints

Objects in Static Equilibrium

- Draw a simple, neat diagram of the system.
- Isolate the object being analyzed. Draw a free-body diagram and then show and label all external forces acting on the object, indicating where those forces are applied. Do not include forces exerted by the object on its surroundings. (For systems that contain more than one object, draw a *separate* free-body diagram for each one.) Try to guess the correct direction for each force. If the direction you select leads to a negative force, do not be alarmed; this merely means that the direction of the force is the opposite of what you guessed.
- Establish a convenient coordinate system for the object and find the components of the forces along the two axes. Then apply the first condition for equilibrium. Remember to keep track of the signs of all force components.
- Choose a convenient axis for calculating the net torque on the object. Remember that the choice of origin for the torque equation is arbitrary; therefore, choose an origin that simplifies your calculation as much as possible. Note that a force that acts along a line passing through the point chosen as the origin gives zero contribution to the torque and thus can be ignored.

The first and second conditions for equilibrium give a set of linear equations containing several unknowns, and these equations can be solved simultaneously.



EXAMPLE 12.1 The Seesaw

A uniform 40.0-N board supports a father and daughter weighing 800 N and 350 N, respectively, as shown in Figure 12.7. If the support (called the *fulcrum*) is under the center of gravity of the board and if the father is 1.00 m from the center, (a) determine the magnitude of the upward force \mathbf{n} exerted on the board by the support.

Solution First note that, in addition to \mathbf{n} , the external forces acting on the board are the downward forces exerted by each person and the force of gravity acting on the board. We know that the board's center of gravity is at its geometric center because we were told the board is uniform. Because the system is in static equilibrium, the upward force \mathbf{n} must balance all the downward forces. From $\Sigma F_y = 0$, we have, once we define upward as the positive y direction,

$$n - 800 \text{ N} - 350 \text{ N} - 40.0 \text{ N} = 0$$

$$n = 1190 \text{ N}$$

(The equation $\Sigma F_x = 0$ also applies, but we do not need to consider it because no forces act horizontally on the board.)

(b) Determine where the child should sit to balance the system.

Solution To find this position, we must invoke the second condition for equilibrium. Taking an axis perpendicular to the page through the center of gravity of the board as the axis for our torque equation (this means that the torques

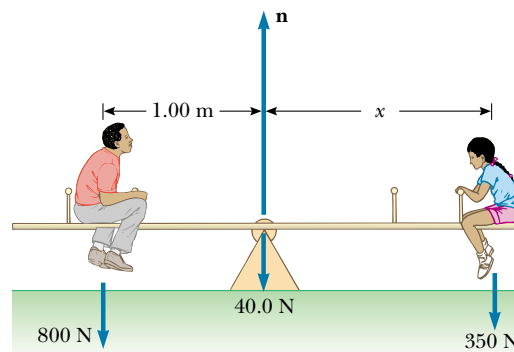

Figure 12.7 A balanced system.

produced by \mathbf{n} and the force of gravity acting on the board about this axis are zero), we see from $\Sigma \tau = 0$ that

$$(800 \text{ N})(1.00 \text{ m}) - (350 \text{ N})x = 0$$

$$x = 2.29 \text{ m}$$

(c) Repeat part (b) for another axis.

Solution To illustrate that the choice of axis is arbitrary, let us choose an axis perpendicular to the page and passing

through the location of the father. Recall that the sign of the torque associated with a force is positive if that force tends to rotate the system counterclockwise, while the sign of the torque is negative if the force tends to rotate the system clockwise. In this case, $\Sigma \tau = 0$ yields

$$n(1.00 \text{ m}) - (40.0 \text{ N})(1.00 \text{ m}) - (350 \text{ N})(1.00 \text{ m} + x) = 0$$

From part (a) we know that $n = 1190 \text{ N}$. Thus, we can solve for x to find $x = 2.29 \text{ m}$. This result is in agreement with the one we obtained in part (b).

Quick Quiz 12.2

In Example 12.1, if the fulcrum did not lie under the board's center of gravity, what other information would you need to solve the problem?

EXAMPLE 12.2 A Weighted Hand

A person holds a 50.0-N sphere in his hand. The forearm is horizontal, as shown in Figure 12.8a. The biceps muscle is attached 3.00 cm from the joint, and the sphere is 35.0 cm from the joint. Find the upward force exerted by the biceps on the forearm and the downward force exerted by the upper arm on the forearm and acting at the joint. Neglect the weight of the forearm.

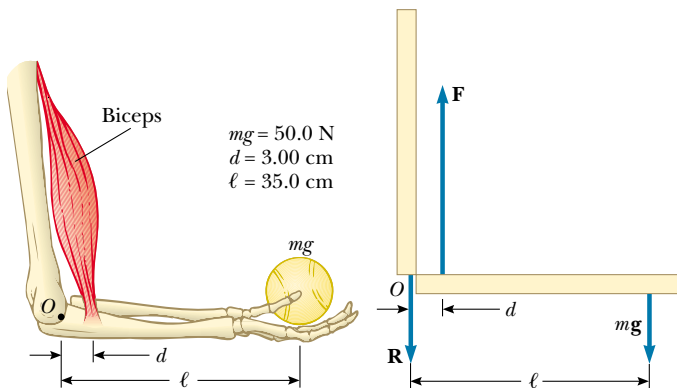

Figure 12.8 (a) The biceps muscle pulls upward with a force \mathbf{F} that is essentially at right angles to the forearm. (b) The mechanical model for the system described in part (a).

Solution We simplify the situation by modeling the forearm as a bar as shown in Figure 12.8b, where \mathbf{F} is the upward force exerted by the biceps and \mathbf{R} is the downward force exerted by the upper arm at the joint. From the first condition for equilibrium, we have, with upward as the positive y direction,

$$(1) \quad \Sigma F_y = F - R - 50.0 \text{ N} = 0$$

From the second condition for equilibrium, we know that the sum of the torques about any point must be zero. With the joint O as the axis, we have

$$Fd - mg\ell = 0$$

$$F(3.00 \text{ cm}) - (50.0 \text{ N})(35.0 \text{ cm}) = 0$$

$$F = 583 \text{ N}$$

This value for F can be substituted into Equation (1) to give $R = 533 \text{ N}$. As this example shows, the forces at joints and in muscles can be extremely large.

Exercise In reality, the biceps makes an angle of 15.0° with the vertical; thus, \mathbf{F} has both a vertical and a horizontal component. Find the magnitude of \mathbf{F} and the components of \mathbf{R} when you include this fact in your analysis.

Answer $F = 604 \text{ N}$, $R_x = 156 \text{ N}$, $R_y = 533 \text{ N}$.

EXAMPLE 12.3 Standing on a Horizontal Beam

A uniform horizontal beam with a length of 8.00 m and a weight of 200 N is attached to a wall by a pin connection. Its far end is supported by a cable that makes an angle of 53.0° with

the horizontal (Fig. 12.9a). If a 600-N person stands 2.00 m from the wall, find the tension in the cable, as well as the magnitude and direction of the force exerted by the wall on the beam.

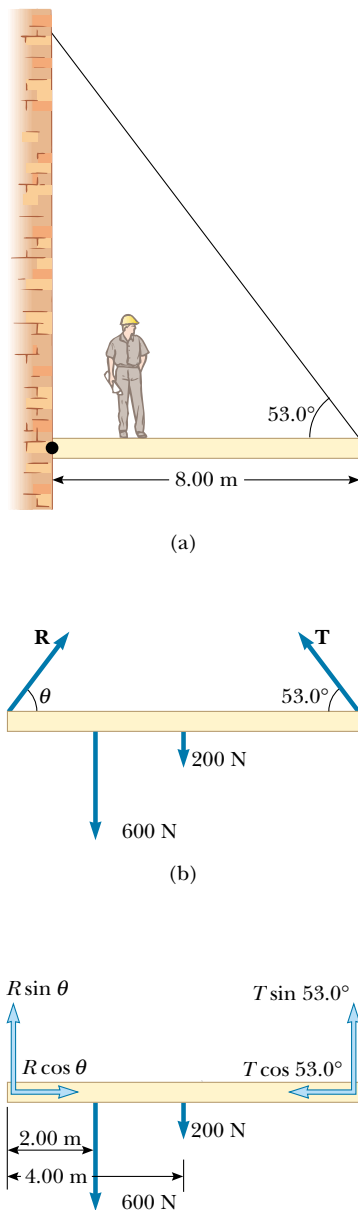

Figure 12.9 (a) A uniform beam supported by a cable. (b) The free-body diagram for the beam. (c) The free-body diagram for the beam showing the components of \mathbf{R} and \mathbf{T} .

Solution First we must identify all the external forces acting on the beam: They are the 200-N force of gravity, the force \mathbf{T} exerted by the cable, the force \mathbf{R} exerted by the wall at the pivot, and the 600-N force that the person exerts on the beam. These forces are all indicated in the free-body diagram for the beam shown in Figure 12.9b. When we consider directions for forces, it sometimes is helpful if we imagine what would happen if a force were suddenly removed. For example, if the wall were to vanish suddenly,

the left end of the beam would probably move to the left as it begins to fall. This tells us that the wall is not only holding the beam up but is also pressing outward against it. Thus, we draw the vector \mathbf{R} as shown in Figure 12.9b. If we resolve \mathbf{T} and \mathbf{R} into horizontal and vertical components, as shown in Figure 12.9c, and apply the first condition for equilibrium, we obtain

$$(1) \quad \sum F_x = R \cos \theta - T \cos 53.0^\circ = 0$$

$$(2) \quad \sum F_y = R \sin \theta + T \sin 53.0^\circ - 600 \text{ N} - 200 \text{ N} = 0$$

where we have chosen rightward and upward as our positive directions. Because R , T , and θ are all unknown, we cannot obtain a solution from these expressions alone. (The number of simultaneous equations must equal the number of unknowns for us to be able to solve for the unknowns.)

Now let us invoke the condition for rotational equilibrium. A convenient axis to choose for our torque equation is the one that passes through the pin connection. The feature that makes this point so convenient is that the force \mathbf{R} and the horizontal component of \mathbf{T} both have a moment arm of zero; hence, these forces provide no torque about this point. Recalling our counterclockwise-equals-positive convention for the sign of the torque about an axis and noting that the moment arms of the 600-N, 200-N, and $T \sin 53.0^\circ$ forces are 2.00 m, 4.00 m, and 8.00 m, respectively, we obtain

$$\sum \tau = (T \sin 53.0^\circ)(8.00 \text{ m}) - (600 \text{ N})(2.00 \text{ m}) - (200 \text{ N})(4.00 \text{ m}) = 0$$

$$T = 313 \text{ N}$$

Thus, the torque equation with this axis gives us one of the unknowns directly! We now substitute this value into Equations (1) and (2) and find that

$$R \cos \theta = 188 \text{ N}$$

$$R \sin \theta = 550 \text{ N}$$

We divide the second equation by the first and, recalling the trigonometric identity $\sin \theta / \cos \theta = \tan \theta$, we obtain

$$\tan \theta = \frac{550 \text{ N}}{188 \text{ N}} = 2.93$$

$$\theta = 71.1^\circ$$

This positive value indicates that our estimate of the direction of \mathbf{R} was accurate.

Finally,

$$R = \frac{188 \text{ N}}{\cos \theta} = \frac{188 \text{ N}}{\cos 71.1^\circ} = 580 \text{ N}$$

If we had selected some other axis for the torque equation, the solution would have been the same. For example, if

we had chosen an axis through the center of gravity of the beam, the torque equation would involve both T and R . However, this equation, coupled with Equations (1) and (2), could still be solved for the unknowns. Try it!

When many forces are involved in a problem of this nature, it is convenient to set up a table. For instance, for the example just given, we could construct the following table. Setting the sum of the terms in the last column equal to zero represents the condition of rotational equilibrium.

Force Component	Moment Arm Relative to O (m)	Torque About O ($N \cdot m$)
$T \sin 53.0^\circ$	8.00	$(8.00) T \sin 53.0^\circ$
$T \cos 53.0^\circ$	0	0
200 N	4.00	$-(4.00)(200)$
600 N	2.00	$-(2.00)(600)$
$R \sin \theta$	0	0
$R \cos \theta$	0	0

EXAMPLE 12.4 The Leaning Ladder

A uniform ladder of length ℓ and weight $mg = 50 \text{ N}$ rests against a smooth, vertical wall (Fig. 12.10a). If the coefficient of static friction between the ladder and the ground is $\mu_s = 0.40$, find the minimum angle θ_{\min} at which the ladder does not slip.

Solution The free-body diagram showing all the external forces acting on the ladder is illustrated in Figure 12.10b. The reaction force \mathbf{R} exerted by the ground on the ladder is the vector sum of a normal force \mathbf{n} and the force of static friction \mathbf{f}_s . The reaction force \mathbf{P} exerted by the wall on the ladder is horizontal because the wall is frictionless. Notice how we have included only forces that act on the ladder. For example, the forces exerted by the ladder on the ground and on the wall are not part of the problem and thus do not appear in the free-body diagram. Applying the first condition

for equilibrium to the ladder, we have

$$\begin{aligned} \sum F_x &= f - P = 0 \\ \sum F_y &= n - mg = 0 \end{aligned}$$

From the second equation we see that $n = mg = 50 \text{ N}$. Furthermore, when the ladder is on the verge of slipping, the force of friction must be a maximum, which is given by $f_{s,\max} = \mu_s n = 0.40(50 \text{ N}) = 20 \text{ N}$. (Recall Eq. 5.8: $f_s \leq \mu_s n$.) Thus, at this angle, $P = 20 \text{ N}$.

To find θ_{\min} , we must use the second condition for equilibrium. When we take the torques about an axis through the origin O at the bottom of the ladder, we have

$$\sum \tau_O = P\ell \sin \theta - mg \frac{\ell}{2} \cos \theta = 0$$

Because $P = 20 \text{ N}$ when the ladder is about to slip, and because $mg = 50 \text{ N}$, this expression gives

$$\tan \theta_{\min} = \frac{mg}{2P} = \frac{50 \text{ N}}{40 \text{ N}} = 1.25$$

$$\theta_{\min} = 51^\circ$$

An alternative approach is to consider the intersection O' of the lines of action of forces mg and \mathbf{P} . Because the torque about any origin must be zero, the torque about O' must be zero. This requires that the line of action of \mathbf{R} (the resultant of \mathbf{n} and \mathbf{f}) pass through O' . In other words, because the ladder is stationary, the three forces acting on it must all pass through some common point. (We say that such forces are *concurrent*.) With this condition, you could then obtain the angle ϕ that \mathbf{R} makes with the horizontal (where ϕ is greater than θ). Because this approach depends on the length of the ladder, you would have to know the value of ℓ to obtain a value for θ_{\min} .

Exercise For the angles labeled in Figure 12.10, show that $\tan \phi = 2 \tan \theta$.

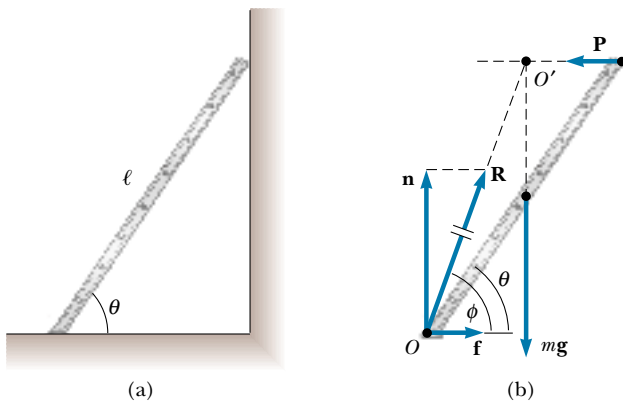

Figure 12.10 (a) A uniform ladder at rest, leaning against a smooth wall. The ground is rough. (b) The free-body diagram for the ladder. Note that the forces \mathbf{R} , $m\mathbf{g}$, and \mathbf{P} pass through a common point O' .

EXAMPLE 12.5 Negotiating a Curb

(a) Estimate the magnitude of the force \mathbf{F} a person must apply to a wheelchair's main wheel to roll up over a sidewalk curb (Fig. 12.11a). This main wheel, which is the one that comes in contact with the curb, has a radius r , and the height of the curb is h .

Solution Normally, the person's hands supply the required force to a slightly smaller wheel that is concentric with the main wheel. We assume that the radius of the smaller wheel is the same as the radius of the main wheel, and so we can use r for our radius. Let us estimate a combined weight of $mg = 1\,400\text{ N}$ for the person and the wheelchair and choose a wheel radius of $r = 30\text{ cm}$, as shown in Figure 12.11b. We also pick a curb height of $h = 10\text{ cm}$. We assume that the wheelchair and occupant are symmetric, and that each wheel supports a weight of 700 N . We then proceed to analyze only one of the wheels.

When the wheel is just about to be raised from the street, the reaction force exerted by the ground on the wheel at point Q goes to zero. Hence, at this time only three forces act on the wheel, as shown in Figure 12.11c. However, the force \mathbf{R} , which is the force exerted on the wheel by the curb, acts at point P , and so if we choose to have our axis of rotation pass through point P , we do not need to include \mathbf{R} in our torque equation. From the triangle OPQ shown in Figure 12.11b, we see that the moment arm d of the gravitational force $m\mathbf{g}$ acting on the wheel relative to point P is

$$d = \sqrt{r^2 - (r - h)^2} = \sqrt{2rh - h^2}$$

The moment arm of \mathbf{F} relative to point P is $2r - h$. Therefore, the net torque acting on the wheel about point P is

$$mgd - F(2r - h) = 0$$

$$mg\sqrt{2rh - h^2} - F(2r - h) = 0$$

$$F = \frac{mg\sqrt{2rh - h^2}}{2r - h}$$

$$F = \frac{(700\text{ N})\sqrt{2(0.3\text{ m})(0.1\text{ m}) - (0.1\text{ m})^2}}{2(0.3\text{ m}) - 0.1\text{ m}} = 300\text{ N}$$

(Notice that we have kept only one digit as significant.) This result indicates that the force that must be applied to each wheel is substantial. You may want to estimate the force required to roll a wheelchair up a typical sidewalk accessibility ramp for comparison.

(b) Determine the magnitude and direction of \mathbf{R} .

Solution We use the first condition for equilibrium to determine the direction:

$$\sum F_x = F - R \cos \theta = 0$$

$$\sum F_y = R \sin \theta - mg = 0$$

Dividing the second equation by the first gives

$$\tan \theta = \frac{mg}{F} = \frac{700\text{ N}}{300\text{ N}}; \quad \theta = 70^\circ$$



(a)

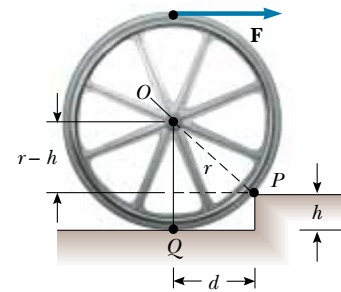

(b)

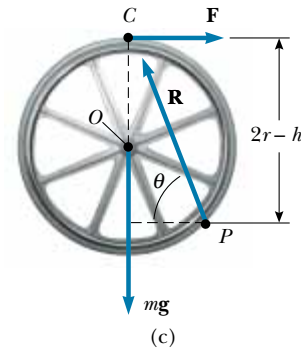

(c)

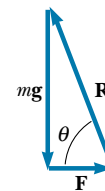

(d)

Figure 12.11 (a) A wheelchair and person of total weight mg being raised over a curb by a force \mathbf{F} . (b) Details of the wheel and curb. (c) The free-body diagram for the wheel when it is just about to be raised. Three forces act on the wheel at this instant: \mathbf{F} , which is exerted by the hand; \mathbf{R} , which is exerted by the curb; and the gravitational force $m\mathbf{g}$. (d) The vector sum of the three external forces acting on the wheel is zero.

We can use the right triangle shown in Figure 12.11d to obtain R :

$$R = \sqrt{(mg)^2 + F^2} = \sqrt{(700 \text{ N})^2 + (300 \text{ N})^2} = 800 \text{ N}$$

Exercise Solve this problem by noting that the three forces acting on the wheel are concurrent (that is, that all three pass through the point C). The three forces form the sides of the triangle shown in Figure 12.11d.

APPLICATION Analysis of a Truss

Roofs, bridges, and other structures that must be both strong and lightweight often are made of trusses similar to the one shown in Figure 12.12a. Imagine that this truss structure represents part of a bridge. To approach this problem, we assume that the structural components are connected by pin joints. We also assume that the entire structure is free to slide horizontally because it sits on “rockers” on each end, which allow it to move back and forth as it undergoes thermal expansion and contraction. Assuming the mass of the bridge structure is negligible compared with the load, let us calculate the forces of tension or compression in all the structural components when it is supporting a 7 200-N load at the center (see Problem 58).

The force notation that we use here is not of our usual format. Until now, we have used the notation F_{AB} to mean “the force exerted by A on B .” For this application, however, all double-letter subscripts on F indicate only the body exerting the force. The body on which a given force acts is not named in the subscript. For example, in Figure 12.12, F_{AB} is the force exerted by strut AB on the pin at A .

First, we apply Newton’s second law to the truss as a whole in the vertical direction. Internal forces do not enter into this accounting. We balance the weight of the load with the normal forces exerted at the two ends by the supports on which the bridge rests:

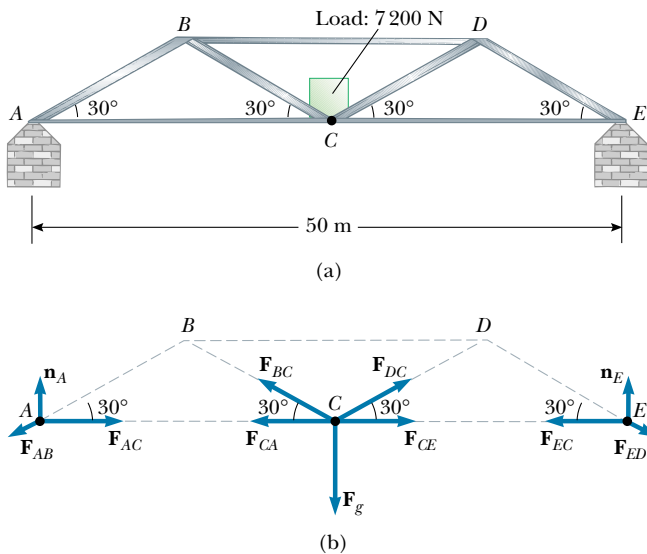

Figure 12.12 (a) Truss structure for a bridge. (b) The forces acting on the pins at points A , C , and E . As an exercise, you should diagram the forces acting on the pin at point B .

$$\begin{aligned} \sum F_y &= n_A + n_E - F_g = 0 \\ n_A + n_E &= 7\,200 \text{ N} \end{aligned}$$

Next, we calculate the torque about A , noting that the overall length of the bridge structure is $L = 50 \text{ m}$:

$$\begin{aligned} \sum \tau &= Ln_E - (L/2)F_g = 0 \\ n_E &= F_g/2 = 3\,600 \text{ N} \end{aligned}$$

Although we could repeat the torque calculation for the right end (point E), it should be clear from symmetry arguments that $n_A = 3\,600 \text{ N}$.

Now let us balance the vertical forces acting on the pin at point A . If we assume that strut AB is in compression, then the force F_{AB} that the strut exerts on the pin at point A has a negative y component. (If the strut is actually in tension, our calculations will result in a negative value for the magnitude of the force, still of the correct size):

$$\begin{aligned} \sum F_y &= n_A - F_{AB} \sin 30^\circ = 0 \\ F_{AB} &= 7\,200 \text{ N} \end{aligned}$$

The positive result shows that our assumption of compression was correct.

We can now find the forces acting in the strut between A and C by considering the horizontal forces acting on the pin at point A . Because point A is not accelerating, we can safely assume that F_{AC} must point toward the right (Fig. 12.12b); this indicates that the bar between points A and C is under tension:

$$\begin{aligned} \sum F_x &= F_{AC} - F_{AB} \cos 30^\circ = 0 \\ F_{AC} &= (7\,200 \text{ N}) \cos 30^\circ = 6\,200 \text{ N} \end{aligned}$$

Now let us consider the vertical forces acting on the pin at point C . We shall assume that strut BC is in tension. (Imagine the subsequent motion of the pin at point C if strut BC were to break suddenly.) On the basis of symmetry, we assert that $F_{BC} = F_{DC}$ and that $F_{AC} = F_{EC}$:

$$\begin{aligned} \sum F_y &= 2 F_{BC} \sin 30^\circ - 7\,200 \text{ N} = 0 \\ F_{BC} &= 7\,200 \text{ N} \end{aligned}$$

Finally, we balance the horizontal forces on B , assuming that strut BD is in compression:

$$\begin{aligned} \sum F_x &= F_{AB} \cos 30^\circ + F_{BC} \cos 30^\circ - F_{BD} = 0 \\ (7\,200 \text{ N}) \cos 30^\circ + (7\,200 \text{ N}) \cos 30^\circ - F_{BD} &= 0 \end{aligned}$$

$$F_{BD} = 12\,000 \text{ N}$$

Thus, the top bar in a bridge of this design must be very strong.

12.4 ELASTIC PROPERTIES OF SOLIDS

In our study of mechanics thus far, we have assumed that objects remain undeformed when external forces act on them. In reality, all objects are deformable. That is, it is possible to change the shape or the size of an object (or both) by applying external forces. As these changes take place, however, internal forces in the object resist the deformation.

We shall discuss the deformation of solids in terms of the concepts of stress and strain. **Stress** is a quantity that is proportional to the force causing a deformation; more specifically, stress is the external force acting on an object per unit cross-sectional area. **Strain** is a measure of the degree of deformation. It is found that, for sufficiently small stresses, **strain is proportional to stress**; the constant of proportionality depends on the material being deformed and on the nature of the deformation. We call this proportionality constant the **elastic modulus**. The elastic modulus is therefore the ratio of the stress to the resulting strain:

$$\text{Elastic modulus} \equiv \frac{\text{stress}}{\text{strain}} \quad (12.5)$$

In a very real sense it is a comparison of what is done to a solid object (a force is applied) and how that object responds (it deforms to some extent).

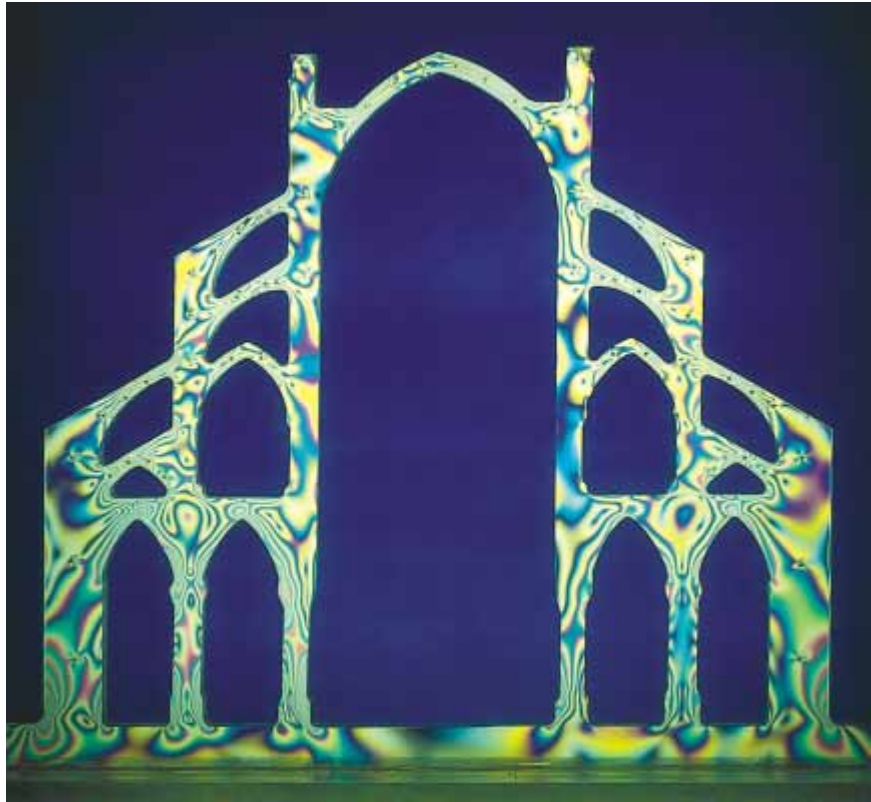

A plastic model of an arch structure under load conditions. The wavy lines indicate regions where the stresses are greatest. Such models are useful in designing architectural components.

We consider three types of deformation and define an elastic modulus for each:

1. **Young's modulus**, which measures the resistance of a solid to a change in its length
2. **Shear modulus**, which measures the resistance to motion of the planes of a solid sliding past each other
3. **Bulk modulus**, which measures the resistance of solids or liquids to changes in their volume

Young's Modulus: Elasticity in Length

Consider a long bar of cross-sectional area A and initial length L_i that is clamped at one end, as in Figure 12.13. When an external force is applied perpendicular to the cross section, internal forces in the bar resist distortion (“stretching”), but the bar attains an equilibrium in which its length L_f is greater than L_i and in which the external force is exactly balanced by internal forces. In such a situation, the bar is said to be stressed. We define the **tensile stress** as the ratio of the magnitude of the external force F to the cross-sectional area A . The **tensile strain** in this case is defined as the ratio of the change in length ΔL to the original length L_i . We define **Young's modulus** by a combination of these two ratios:

$$Y = \frac{\text{tensile stress}}{\text{tensile strain}} = \frac{F/A}{\Delta L/L_i} \quad (12.6)$$

Young's modulus is typically used to characterize a rod or wire stressed under either tension or compression. Note that because strain is a dimensionless quantity, Y has units of force per unit area. Typical values are given in Table 12.1. Experiments show (a) that for a fixed applied force, the change in length is proportional to the original length and (b) that the force necessary to produce a given strain is proportional to the cross-sectional area. Both of these observations are in accord with Equation 12.6.

The **elastic limit** of a substance is defined as the maximum stress that can be applied to the substance before it becomes permanently deformed. It is possible to exceed the elastic limit of a substance by applying a sufficiently large stress, as seen in Figure 12.14. Initially, a stress–strain curve is a straight line. As the stress increases, however, the curve is no longer straight. When the stress exceeds the elas-

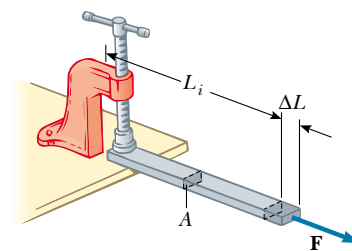

Figure 12.13 A long bar clamped at one end is stretched by an amount ΔL under the action of a force F .

Young's modulus

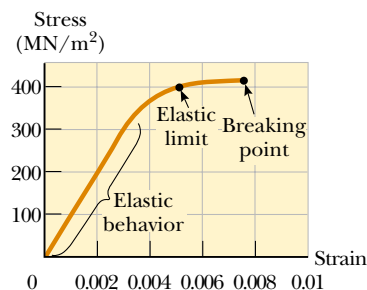

Figure 12.14 Stress-versus-strain curve for an elastic solid.

TABLE 12.1 Typical Values for Elastic Modulus

Substance	Young's Modulus (N/m ²)	Shear Modulus (N/m ²)	Bulk Modulus (N/m ²)
Tungsten	35×10^{10}	14×10^{10}	20×10^{10}
Steel	20×10^{10}	8.4×10^{10}	6×10^{10}
Copper	11×10^{10}	4.2×10^{10}	14×10^{10}
Brass	9.1×10^{10}	3.5×10^{10}	6.1×10^{10}
Aluminum	7.0×10^{10}	2.5×10^{10}	7.0×10^{10}
Glass	$6.5\text{--}7.8 \times 10^{10}$	$2.6\text{--}3.2 \times 10^{10}$	$5.0\text{--}5.5 \times 10^{10}$
Quartz	5.6×10^{10}	2.6×10^{10}	2.7×10^{10}
Water	—	—	0.21×10^{10}
Mercury	—	—	2.8×10^{10}

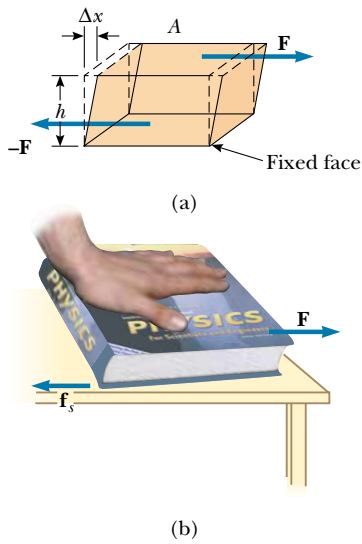

Figure 12.15 (a) A shear deformation in which a rectangular block is distorted by two forces of equal magnitude but opposite directions applied to two parallel faces. (b) A book under shear stress.

Shear modulus

QuickLab

Estimate the shear modulus for the pages of your textbook. Does the thickness of the book have any effect on the modulus value?

Bulk modulus

tic limit, the object is permanently distorted and does not return to its original shape after the stress is removed. Hence, the shape of the object is permanently changed. As the stress is increased even further, the material ultimately breaks.

Quick Quiz 12.3

What is Young's modulus for the elastic solid whose stress–strain curve is depicted in Figure 12.14?

Quick Quiz 12.4

A material is said to be *ductile* if it can be stressed well beyond its elastic limit without breaking. A *brittle* material is one that breaks soon after the elastic limit is reached. How would you classify the material in Figure 12.14?

Shear Modulus: Elasticity of Shape

Another type of deformation occurs when an object is subjected to a force tangential to one of its faces while the opposite face is held fixed by another force (Fig. 12.15a). The stress in this case is called a shear stress. If the object is originally a rectangular block, a shear stress results in a shape whose cross-section is a parallelogram. A book pushed sideways, as shown in Figure 12.15b, is an example of an object subjected to a shear stress. To a first approximation (for small distortions), no change in volume occurs with this deformation.

We define the **shear stress** as F/A , the ratio of the tangential force to the area A of the face being sheared. The **shear strain** is defined as the ratio $\Delta x/h$, where Δx is the horizontal distance that the sheared face moves and h is the height of the object. In terms of these quantities, the **shear modulus** is

$$S = \frac{\text{shear stress}}{\text{shear strain}} = \frac{F/A}{\Delta x/h} \quad (12.7)$$

Values of the shear modulus for some representative materials are given in Table 12.1. The unit of shear modulus is force per unit area.

Bulk Modulus: Volume Elasticity

Bulk modulus characterizes the response of a substance to uniform squeezing or to a reduction in pressure when the object is placed in a partial vacuum. Suppose that the external forces acting on an object are at right angles to all its faces, as shown in Figure 12.16, and that they are distributed uniformly over all the faces. As we shall see in Chapter 15, such a uniform distribution of forces occurs when an object is immersed in a fluid. An object subject to this type of deformation undergoes a change in volume but no change in shape. The **volume stress** is defined as the ratio of the magnitude of the normal force F to the area A . The quantity $P = F/A$ is called the **pressure**. If the pressure on an object changes by an amount $\Delta P = \Delta F/A$, then the object will experience a volume change ΔV . The **volume strain** is equal to the change in volume ΔV divided by the initial volume V_i . Thus, from Equation 12.5, we can characterize a volume (“bulk”) compression in terms of the **bulk modulus**, which is defined as

$$B \equiv \frac{\text{volume stress}}{\text{volume strain}} = -\frac{\Delta F/A}{\Delta V/V_i} = -\frac{\Delta P}{\Delta V/V_i} \quad (12.8)$$

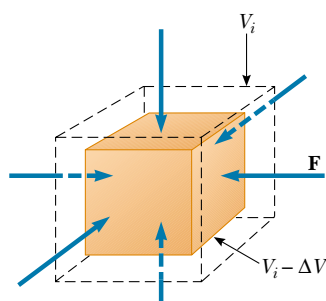

Figure 12.16 When a solid is under uniform pressure, it undergoes a change in volume but no change in shape. This cube is compressed on all sides by forces normal to its six faces.

A negative sign is inserted in this defining equation so that B is a positive number. This maneuver is necessary because an increase in pressure (positive ΔP) causes a decrease in volume (negative ΔV) and vice versa.

Table 12.1 lists bulk moduli for some materials. If you look up such values in a different source, you often find that the reciprocal of the bulk modulus is listed. The reciprocal of the bulk modulus is called the **compressibility** of the material.

Note from Table 12.1 that both solids and liquids have a bulk modulus. However, no shear modulus and no Young's modulus are given for liquids because a liquid does not sustain a shearing stress or a tensile stress (it flows instead).

Prestressed Concrete

If the stress on a solid object exceeds a certain value, the object fractures. The maximum stress that can be applied before fracture occurs depends on the nature of the material and on the type of applied stress. For example, concrete has a tensile strength of about $2 \times 10^6 \text{ N/m}^2$, a compressive strength of $20 \times 10^6 \text{ N/m}^2$, and a shear strength of $2 \times 10^6 \text{ N/m}^2$. If the applied stress exceeds these values, the concrete fractures. It is common practice to use large safety factors to prevent failure in concrete structures.

Concrete is normally very brittle when it is cast in thin sections. Thus, concrete slabs tend to sag and crack at unsupported areas, as shown in Figure 12.17a. The slab can be strengthened by the use of steel rods to reinforce the concrete, as illustrated in Figure 12.17b. Because concrete is much stronger under compression (squeezing) than under tension (stretching) or shear, vertical columns of concrete can support very heavy loads, whereas horizontal beams of concrete tend to sag and crack. However, a significant increase in shear strength is achieved if the reinforced concrete is prestressed, as shown in Figure 12.17c. As the concrete is being poured, the steel rods are held under tension by external forces. The external

QuickLab

Support a new flat eraser (art gum or Pink Pearl will do) on two parallel pencils at least 3 cm apart. Press down on the middle of the top surface just enough to make the top face of the eraser curve a bit. Is the top face under tension or compression? How about the bottom? Why does a flat slab of concrete supported at the ends tend to crack on the bottom face and not the top?

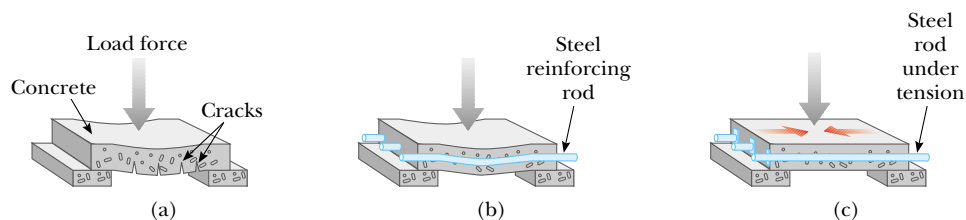

Figure 12.17 (a) A concrete slab with no reinforcement tends to crack under a heavy load. (b) The strength of the concrete is increased by using steel reinforcement rods. (c) The concrete is further strengthened by prestressing it with steel rods under tension.

forces are released after the concrete cures; this results in a permanent tension in the steel and hence a compressive stress on the concrete. This enables the concrete slab to support a much heavier load.

EXAMPLE 12.6 Stage Design

Recall Example 8.10, in which we analyzed a cable used to support an actor as he swung onto the stage. The tension in the cable was 940 N. What diameter should a 10-m-long steel wire have if we do not want it to stretch more than 0.5 cm under these conditions?

Solution From the definition of Young's modulus, we can solve for the required cross-sectional area. Assuming that the cross section is circular, we can determine the diameter of the wire. From Equation 12.6, we have

$$Y = \frac{F/A}{\Delta L/L_i}$$

$$A = \frac{FL_i}{Y\Delta L} = \frac{(940 \text{ N})(10 \text{ m})}{(20 \times 10^{10} \text{ N/m}^2)(0.005 \text{ m})} = 9.4 \times 10^{-6} \text{ m}^2$$

The radius of the wire can be found from $A = \pi r^2$:

$$r = \sqrt{\frac{A}{\pi}} = \sqrt{\frac{9.4 \times 10^{-6} \text{ m}^2}{\pi}} = 1.7 \times 10^{-3} \text{ m} = 1.7 \text{ mm}$$

$$d = 2r = 2(1.7 \text{ mm}) = 3.4 \text{ mm}$$

To provide a large margin of safety, we would probably use a flexible cable made up of many smaller wires having a total cross-sectional area substantially greater than our calculated value.

EXAMPLE 12.7 Squeezing a Brass Sphere

A solid brass sphere is initially surrounded by air, and the air pressure exerted on it is $1.0 \times 10^5 \text{ N/m}^2$ (normal atmospheric pressure). The sphere is lowered into the ocean to a depth at which the pressure is $2.0 \times 10^7 \text{ N/m}^2$. The volume of the sphere in air is 0.50 m^3 . By how much does this volume change once the sphere is submerged?

Solution From the definition of bulk modulus, we have

$$B = -\frac{\Delta P}{\Delta V/V_i}$$

$$\Delta V = -\frac{V_i \Delta P}{B}$$

Because the final pressure is so much greater than the initial pressure, we can neglect the initial pressure and state that $\Delta P = P_f - P_i \approx P_f = 2.0 \times 10^7 \text{ N/m}^2$. Therefore,

$$\Delta V = -\frac{(0.50 \text{ m}^3)(2.0 \times 10^7 \text{ N/m}^2)}{6.1 \times 10^{10} \text{ N/m}^2} = -1.6 \times 10^{-4} \text{ m}^3$$

The negative sign indicates a decrease in volume.

SUMMARY

A rigid object is in **equilibrium** if and only if **the resultant external force acting on it is zero and the resultant external torque on it is zero about any axis:**

$$\sum \mathbf{F} = 0 \quad (12.1)$$

$$\sum \boldsymbol{\tau} = 0 \quad (12.2)$$

The first condition is the condition for translational equilibrium, and the second is the condition for rotational equilibrium. These two equations allow you to analyze a great variety of problems. Make sure you can identify forces unambiguously, create a free-body diagram, and then apply Equations 12.1 and 12.2 and solve for the unknowns.

The force of gravity exerted on an object can be considered as acting at a single point called the **center of gravity**. The center of gravity of an object coincides with its center of mass if the object is in a uniform gravitational field.

We can describe the elastic properties of a substance using the concepts of stress and strain. **Stress** is a quantity proportional to the force producing a deformation; **strain** is a measure of the degree of deformation. Strain is proportional to stress, and the constant of proportionality is the **elastic modulus**:



$$\text{Elastic modulus} \equiv \frac{\text{stress}}{\text{strain}} \quad (12.5)$$

Three common types of deformation are (1) the resistance of a solid to elongation under a load, characterized by **Young's modulus** Y ; (2) the resistance of a solid to the motion of internal planes sliding past each other, characterized by the **shear modulus** S ; and (3) the resistance of a solid or fluid to a volume change, characterized by the **bulk modulus** B .

QUESTIONS

- Can a body be in equilibrium if only one external force acts on it? Explain.
- Can a body be in equilibrium if it is in motion? Explain.
- Locate the center of gravity for the following uniform objects: (a) sphere, (b) cube, (c) right circular cylinder.
- The center of gravity of an object may be located outside the object. Give a few examples for which this is the case.
- You are given an arbitrarily shaped piece of plywood, together with a hammer, nail, and plumb bob. How could you use these items to locate the center of gravity of the plywood? (*Hint*: Use the nail to suspend the plywood.)
- For a chair to be balanced on one leg, where must the center of gravity of the chair be located?
- Can an object be in equilibrium if the only torques acting on it produce clockwise rotation?
- A tall crate and a short crate of equal mass are placed side by side on an incline (without touching each other). As the incline angle is increased, which crate will topple first? Explain.
- When lifting a heavy object, why is it recommended to keep the back as vertical as possible, lifting from the knees, rather than bending over and lifting from the waist?
- Give a few examples in which several forces are acting on a system in such a way that their sum is zero but the system is not in equilibrium.
- If you measure the net torque and the net force on a system to be zero, (a) could the system still be rotating with respect to you? (b) Could it be translating with respect to you?
- A ladder is resting inclined against a wall. Would you feel safer climbing up the ladder if you were told that the ground is frictionless but the wall is rough or that the wall is frictionless but the ground is rough? Justify your answer.
- What kind of deformation does a cube of Jell-O exhibit when it "jiggles"?
- Ruins of ancient Greek temples often have intact vertical columns, but few horizontal slabs of stone are still in place. Can you think of a reason why this is so?

PROBLEMS

1, 2, 3 = straightforward, intermediate, challenging \square = full solution available in the *Student Solutions Manual and Study Guide*
 WEB = solution posted at <http://www.saunderscollege.com/physics/>  = Computer useful in solving problem  = Interactive Physics
 \square = paired numerical/symbolic problems

Section 12.1 The Conditions for Equilibrium

- A baseball player holds a 36-oz bat (weight = 10.0 N) with one hand at the point O (Fig. P12.1). The bat is in equilibrium. The weight of the bat acts along a line 60.0 cm to the right of O . Determine the force and the torque exerted on the bat by the player.

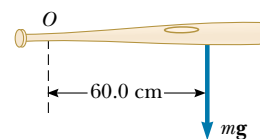

Figure P12.1

2. Write the necessary conditions of equilibrium for the body shown in Figure P12.2. Take the origin of the torque equation at the point O .

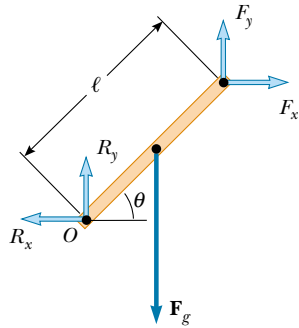

Figure P12.2

- WEB 3. A uniform beam of mass m_b and length ℓ supports blocks of masses m_1 and m_2 at two positions, as shown in Figure P12.3. The beam rests on two points. For what value of x will the beam be balanced at P such that the normal force at O is zero?

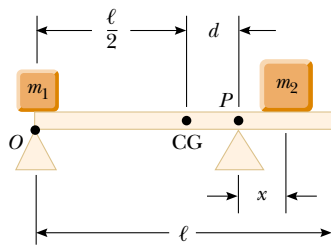

Figure P12.3

4. A student gets his car stuck in a snow drift. Not at a loss, having studied physics, he attaches one end of a stout rope to the vehicle and the other end to the trunk of a nearby tree, allowing for a very small amount of slack. The student then exerts a force \mathbf{F} on the center of the rope in the direction perpendicular to the car–tree line, as shown in Figure P12.4. If the rope is inextensible and if the magnitude of the applied force is 500 N, what is the force on the car? (Assume equilibrium conditions.)

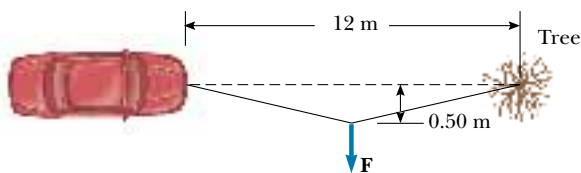

Figure P12.4

Section 12.2 More on the Center of Gravity

5. A 3.00-kg particle is located on the x axis at $x = -5.00$ m, and a 4.00-kg particle is located on the x axis at $x = 3.00$ m. Find the center of gravity of this two-particle system.
6. A circular pizza of radius R has a circular piece of radius $R/2$ removed from one side, as shown in Figure P12.6. Clearly, the center of gravity has moved from C to C' along the x axis. Show that the distance from C to C' is $R/6$. (Assume that the thickness and density of the pizza are uniform throughout.)

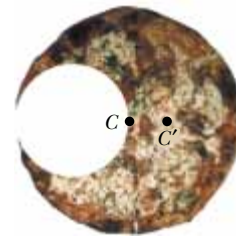

Figure P12.6

7. A carpenter's square has the shape of an L, as shown in Figure P12.7. Locate its center of gravity.

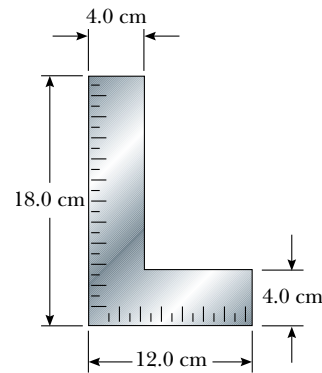

Figure P12.7

8. Pat builds a track for his model car out of wood, as illustrated in Figure P12.8. The track is 5.00 cm wide, 1.00 m high, and 3.00 m long, and it is solid. The runway is cut so that it forms a parabola described by the equation $y = (x - 3)^2/9$. Locate the horizontal position of the center of gravity of this track.
- WEB 9. Consider the following mass distribution: 5.00 kg at $(0, 0)$ m, 3.00 kg at $(0, 4.00)$ m, and 4.00 kg at $(3.00, 0)$ m. Where should a fourth mass of 8.00 kg be placed so that the center of gravity of the four-mass arrangement will be at $(0, 0)$?

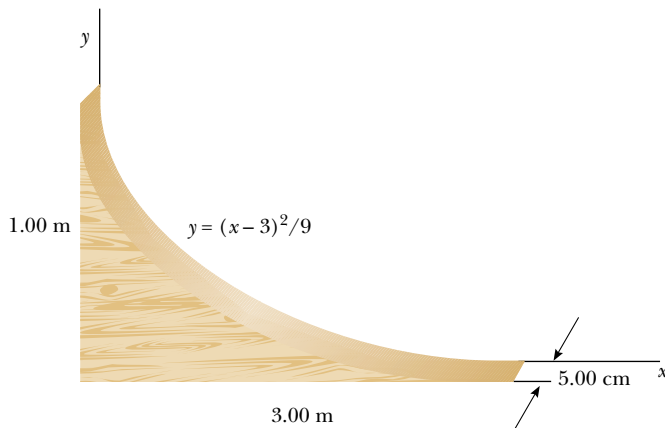

Figure P12.8

10. Figure P12.10 shows three uniform objects: a rod, a right triangle, and a square. Their masses in kilograms and their coordinates in meters are given. Determine the center of gravity for the three-object system.

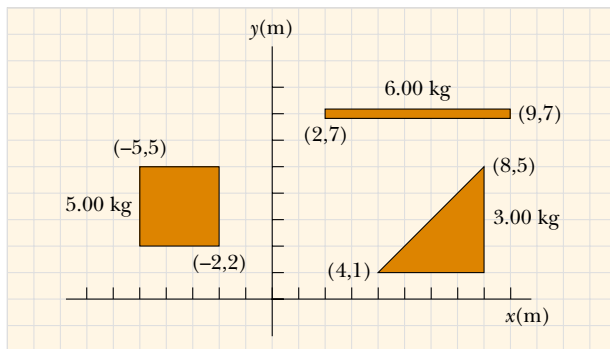

Figure P12.10

Section 12.3 Examples of Rigid Objects in Static Equilibrium

11. Stephen is pushing his sister Joyce in a wheelbarrow when it is stopped by a brick 8.00 cm high (Fig. P12.11). The handles make an angle of 15.0° from the horizontal. A downward force of 400 N is exerted on the wheel, which has a radius of 20.0 cm. (a) What force must Stephen apply along the handles to just start the wheel over the brick? (b) What is the force (magnitude and direction) that the brick exerts on the wheel just as the wheel begins to lift over the brick? Assume in both parts (a) and (b) that the brick remains fixed and does not slide along the ground.
12. Two pans of a balance are 50.0 cm apart. The fulcrum of the balance has been shifted 1.00 cm away from the center by a dishonest shopkeeper. By what percentage is the true weight of the goods being marked up by the shopkeeper? (Assume that the balance has negligible mass.)



Figure P12.11

13. A 15.0-m uniform ladder weighing 500 N rests against a frictionless wall. The ladder makes a 60.0° angle with the horizontal. (a) Find the horizontal and vertical forces that the ground exerts on the base of the ladder when an 800-N firefighter is 4.00 m from the bottom. (b) If the ladder is just on the verge of slipping when the firefighter is 9.00 m up, what is the coefficient of static friction between the ladder and the ground?
14. A uniform ladder of length L and mass m_1 rests against a frictionless wall. The ladder makes an angle θ with the horizontal. (a) Find the horizontal and vertical forces that the ground exerts on the base of the ladder when a firefighter of mass m_2 is a distance x from the bottom. (b) If the ladder is just on the verge of slipping when the firefighter is a distance d from the bottom, what is the coefficient of static friction between the ladder and the ground?
15. Figure P12.15 shows a claw hammer as it is being used to pull a nail out of a horizontal surface. If a force of magnitude 150 N is exerted horizontally as shown, find



Figure P12.15

(a) the force exerted by the hammer claws on the nail and (b) the force exerted by the surface on the point of contact with the hammer head. Assume that the force the hammer exerts on the nail is parallel to the nail.

16. A uniform plank with a length of 6.00 m and a mass of 30.0 kg rests horizontally across two horizontal bars of a scaffold. The bars are 4.50 m apart, and 1.50 m of the plank hangs over one side of the scaffold. Draw a free-body diagram for the plank. How far can a painter with a mass of 70.0 kg walk on the overhanging part of the plank before it tips?
17. A 1 500-kg automobile has a wheel base (the distance between the axles) of 3.00 m. The center of mass of the automobile is on the center line at a point 1.20 m behind the front axle. Find the force exerted by the ground on each wheel.
18. A vertical post with a square cross section is 10.0 m tall. Its bottom end is encased in a base 1.50 m tall that is precisely square but slightly loose. A force of 5.50 N to the right acts on the top of the post. The base maintains the post in equilibrium. Find the force that the top of the right sidewall of the base exerts on the post. Find the force that the bottom of the left sidewall of the base exerts on the post.
19. A flexible chain weighing 40.0 N hangs between two hooks located at the same height (Fig. P12.19). At each hook, the tangent to the chain makes an angle $\theta = 42.0^\circ$ with the horizontal. Find (a) the magnitude of the force each hook exerts on the chain and (b) the tension in the chain at its midpoint. (*Hint:* For part (b), make a free-body diagram for half the chain.)

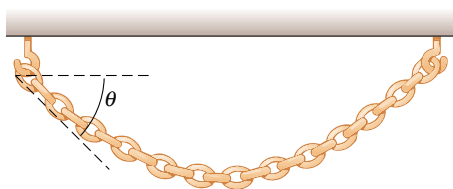

Figure P12.19

20. A hemispherical sign 1.00 m in diameter and of uniform mass density is supported by two strings, as shown in Figure P12.20. What fraction of the sign's weight is supported by each string?
21. Sir Lost-a-Lot dons his armor and sets out from the castle on his trusty steed in his quest to improve communication between damsels and dragons (Fig. P12.21). Unfortunately, his squire lowered the draw bridge too far and finally stopped lowering it when it was 20.0° below the horizontal. Lost-a-Lot and his horse stop when their combined center of mass is 1.00 m from the end of the bridge. The bridge is 8.00 m long and has a mass of 2 000 kg. The lift cable is attached to the bridge 5.00 m from the hinge at the castle end and to a point on the castle wall 12.0 m above the bridge. Lost-a-Lot's mass

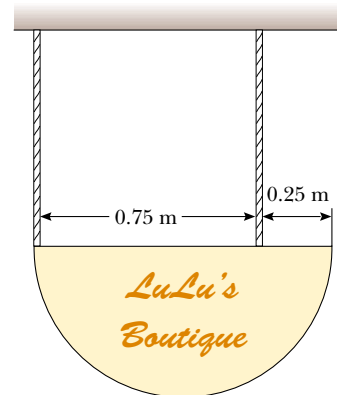

Figure P12.20

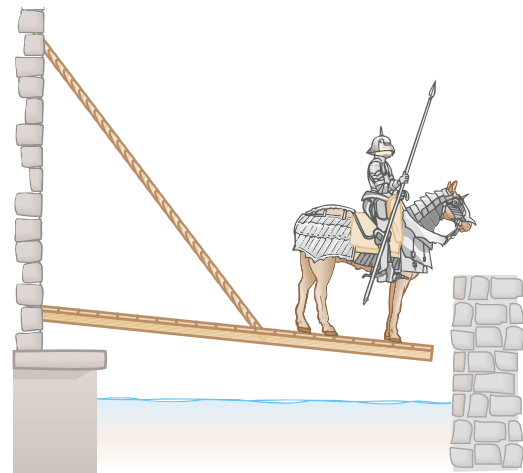

Figure P12.21

combined with that of his armor and steed is 1 000 kg. Determine (a) the tension in the cable, as well as (b) the horizontal and (c) the vertical force components acting on the bridge at the hinge.

22. Two identical, uniform bricks of length L are placed in a stack over the edge of a horizontal surface such that the maximum possible overhang without falling is achieved, as shown in Figure P12.22. Find the distance x .

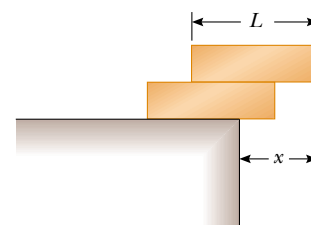

Figure P12.22

23. A vaulter holds a 29.4-N pole in equilibrium by exerting an upward force \mathbf{U} with her leading hand and a downward force \mathbf{D} with her trailing hand, as shown in Figure P12.23. Point C is the center of gravity of the pole. What are the magnitudes of \mathbf{U} and \mathbf{D} ?

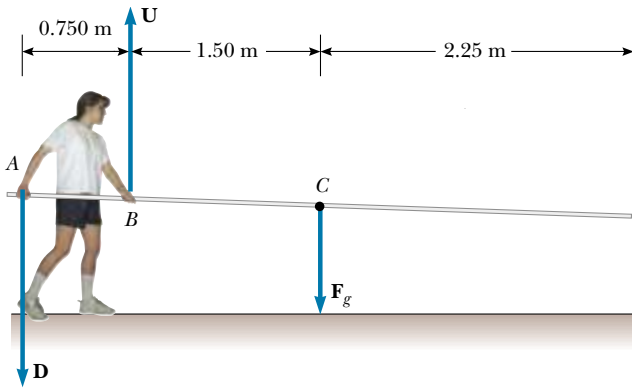

Figure P12.23

Section 12.4 Elastic Properties of Solids

24. Assume that Young's modulus for bone is $1.50 \times 10^{10} \text{ N/m}^2$ and that a bone will fracture if more than $1.50 \times 10^8 \text{ N/m}^2$ is exerted. (a) What is the maximum force that can be exerted on the femur bone in the leg if it has a minimum effective diameter of 2.50 cm? (b) If a force of this magnitude is applied compressively, by how much does the 25.0-cm-long bone shorten?
25. A 200-kg load is hung on a wire with a length of 4.00 m, a cross-sectional area of $0.200 \times 10^{-4} \text{ m}^2$, and a Young's modulus of $8.00 \times 10^{10} \text{ N/m}^2$. What is its increase in length?
26. A steel wire 1 mm in diameter can support a tension of 0.2 kN. Suppose you need a cable made of these wires to support a tension of 20 kN. The cable's diameter should be of what order of magnitude?
27. A child slides across a floor in a pair of rubber-soled shoes. The frictional force acting on each foot is 20.0 N. The footprint area of each shoe's sole is 14.0 cm^2 , and the thickness of each sole is 5.00 mm. Find the horizontal distance by which the upper and lower surfaces of each sole are offset. The shear modulus of the rubber is $3.00 \times 10^6 \text{ N/m}^2$.
28. **Review Problem.** A 30.0-kg hammer strikes a steel spike 2.30 cm in diameter while moving with a speed of 20.0 m/s. The hammer rebounds with a speed of 10.0 m/s after 0.110 s. What is the average strain in the spike during the impact?
29. If the elastic limit of copper is $1.50 \times 10^8 \text{ N/m}^2$, determine the minimum diameter a copper wire can have under a load of 10.0 kg if its elastic limit is not to be exceeded.
30. **Review Problem.** A 2.00-m-long cylindrical steel wire with a cross-sectional diameter of 4.00 mm is placed over a light frictionless pulley, with one end of the wire connected to a 5.00-kg mass and the other end connected to a 3.00-kg mass. By how much does the wire stretch while the masses are in motion?
31. **Review Problem.** A cylindrical steel wire of length L_i with a cross-sectional diameter d is placed over a light frictionless pulley, with one end of the wire connected to a mass m_1 and the other end connected to a mass m_2 . By how much does the wire stretch while the masses are in motion?
32. Calculate the density of sea water at a depth of 1 000 m, where the water pressure is about $1.00 \times 10^7 \text{ N/m}^2$. (The density of sea water is $1.030 \times 10^3 \text{ kg/m}^3$ at the surface.)
33. **WEB** If the shear stress exceeds about $4.00 \times 10^8 \text{ N/m}^2$, steel ruptures. Determine the shearing force necessary (a) to shear a steel bolt 1.00 cm in diameter and (b) to punch a 1.00-cm-diameter hole in a steel plate 0.500 cm thick.
34. (a) Find the minimum diameter of a steel wire 18.0 m long that elongates no more than 9.00 mm when a load of 380 kg is hung on its lower end. (b) If the elastic limit for this steel is $3.00 \times 10^8 \text{ N/m}^2$, does permanent deformation occur with this load?
35. When water freezes, it expands by about 9.00%. What would be the pressure increase inside your automobile's engine block if the water in it froze? (The bulk modulus of ice is $2.00 \times 10^9 \text{ N/m}^2$.)
36. For safety in climbing, a mountaineer uses a 50.0-m nylon rope that is 10.0 mm in diameter. When supporting the 90.0-kg climber on one end, the rope elongates by 1.60 m. Find Young's modulus for the rope material.

ADDITIONAL PROBLEMS

37. A bridge with a length of 50.0 m and a mass of $8.00 \times 10^4 \text{ kg}$ is supported on a smooth pier at each end, as illustrated in Figure P12.37. A truck of mass $3.00 \times 10^4 \text{ kg}$

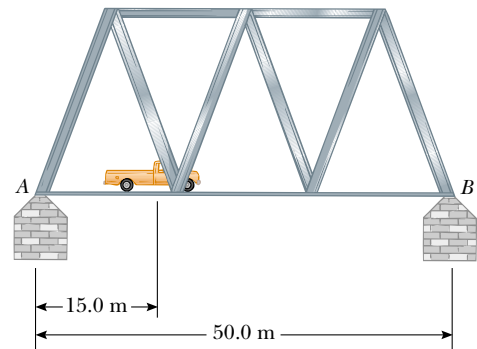

Figure P12.37

is located 15.0 m from one end. What are the forces on the bridge at the points of support?

38. A frame in the shape of the letter **A** is formed from two uniform pieces of metal, each of weight 26.0 N and length 1.00 m. They are hinged at the top and held together by a horizontal wire 1.20 m in length (Fig. P12.38). The structure rests on a frictionless surface. If the wire is connected at points a distance of 0.650 m from the top of the frame, determine the tension in the wire.

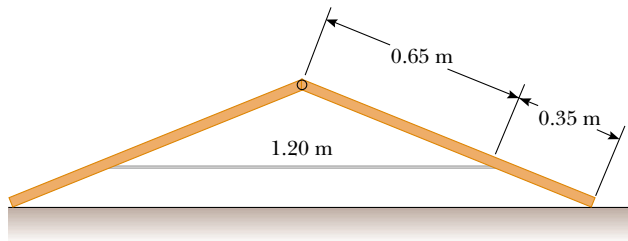

Figure P12.38

39. Refer to Figure 12.17c. A lintel of prestressed reinforced concrete is 1.50 m long. The cross-sectional area of the concrete is 50.0 cm². The concrete encloses one steel reinforcing rod with a cross-sectional area of 1.50 cm². The rod joins two strong end plates. Young's modulus for the concrete is 30.0×10^9 N/m². After the concrete cures and the original tension T_1 in the rod is released, the concrete will be under a compressive stress of 8.00×10^6 N/m². (a) By what distance will the rod compress the concrete when the original tension in the rod is released? (b) Under what tension T_2 will the rod still be? (c) How much longer than its unstressed length will the rod then be? (d) When the concrete was poured, the rod should have been stretched by what extension distance from its unstressed length? (e) Find the required original tension T_1 in the rod.
40. A solid sphere of radius R and mass M is placed in a trough, as shown in Figure P12.40. The inner surfaces of the trough are frictionless. Determine the forces exerted by the trough on the sphere at the two contact points.
41. A 10.0-kg monkey climbs up a 120-N uniform ladder of length L , as shown in Figure P12.41. The upper and

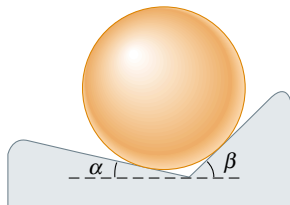

Figure P12.40

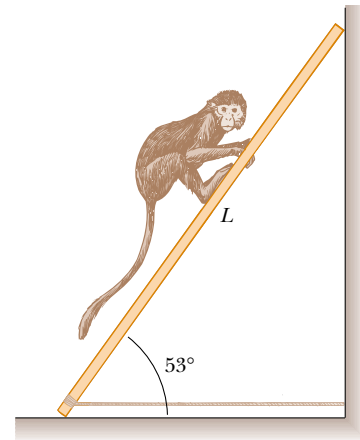

Figure P12.41

lower ends of the ladder rest on frictionless surfaces. The lower end is fastened to the wall by a horizontal rope that can support a maximum tension of 110 N. (a) Draw a free-body diagram for the ladder. (b) Find the tension in the rope when the monkey is one third the way up the ladder. (c) Find the maximum distance d that the monkey can climb up the ladder before the rope breaks. Express your answer as a fraction of L .

42. A hungry bear weighing 700 N walks out on a beam in an attempt to retrieve a basket of food hanging at the end of the beam (Fig. P12.42). The beam is uniform, weighs 200 N, and is 6.00 m long; the basket weighs 80.0 N. (a) Draw a free-body diagram for the beam. (b) When the bear is at $x = 1.00$ m, find the tension in the wire and the components of the force exerted by the wall on the left end of the beam. (c) If the wire can withstand a maximum tension of 900 N, what is the maximum distance that the bear can walk before the wire breaks?

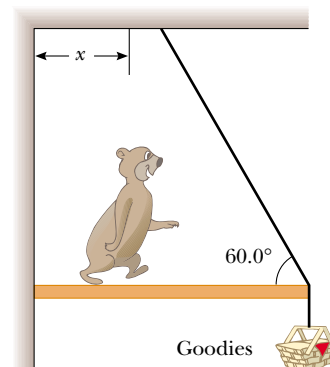

Figure P12.42

43. Old MacDonald had a farm, and on that farm he had a gate (Fig. P12.43). The gate is 3.00 m wide and 1.80 m

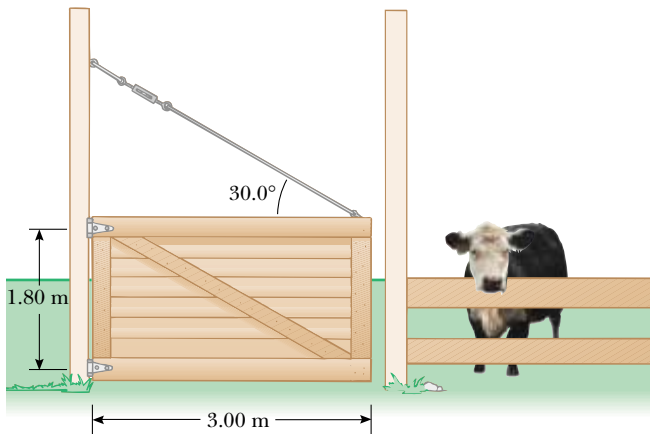

Figure P12.43

high, with hinges attached to the top and bottom. The guy wire makes an angle of 30.0° with the top of the gate and is tightened by a turn buckle to a tension of 200 N. The mass of the gate is 40.0 kg. (a) Determine the horizontal force exerted on the gate by the bottom hinge. (b) Find the horizontal force exerted by the upper hinge. (c) Determine the combined vertical force exerted by both hinges. (d) What must the tension in the guy wire be so that the horizontal force exerted by the upper hinge is zero?

44. A 1 200-N uniform boom is supported by a cable, as illustrated in Figure P12.44. The boom is pivoted at the bottom, and a 2 000-N object hangs from its top. Find the tension in the cable and the components of the reaction force exerted on the boom by the floor.

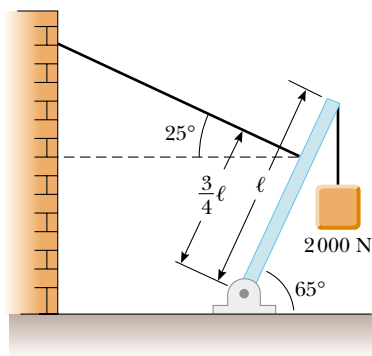

Figure P12.44

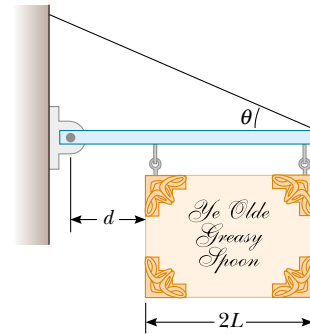

Figure P12.45

46. A crane of mass 3 000 kg supports a load of 10 000 kg as illustrated in Figure P12.46. The crane is pivoted with a frictionless pin at A and rests against a smooth support at B. Find the reaction forces at A and B.

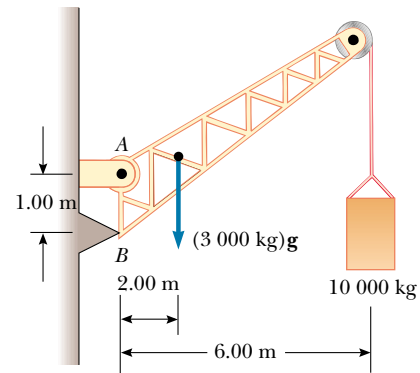

Figure P12.46

- WEB 45. A uniform sign of weight F_g and width $2L$ hangs from a light, horizontal beam hinged at the wall and supported by a cable (Fig. P12.45). Determine (a) the tension in the cable and (b) the components of the reaction force exerted by the wall on the beam in terms of F_g , d , L , and θ .

47. A ladder having a uniform density and a mass m rests against a frictionless vertical wall, making an angle 60.0° with the horizontal. The lower end rests on a flat surface, where the coefficient of static friction is $\mu_s = 0.400$. A window cleaner having a mass $M = 2m$ attempts to climb the ladder. What fraction of the length L of the ladder will the worker have reached when the ladder begins to slip?
48. A uniform ladder weighing 200 N is leaning against a wall (see Fig. 12.10). The ladder slips when $\theta = 60.0^\circ$. Assuming that the coefficients of static friction at the wall and the ground are the same, obtain a value for μ_s .
49. A 10 000-N shark is supported by a cable attached to a 4.00-m rod that can pivot at its base. Calculate the tension in the tie-rope between the wall and the rod if it is holding the system in the position shown in Figure P12.49. Find the horizontal and vertical forces exerted on the base of the rod. (Neglect the weight of the rod.)

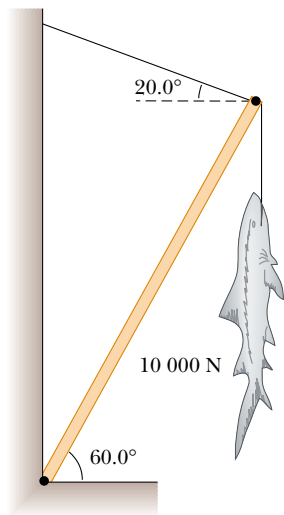
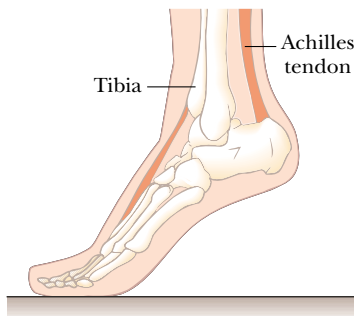
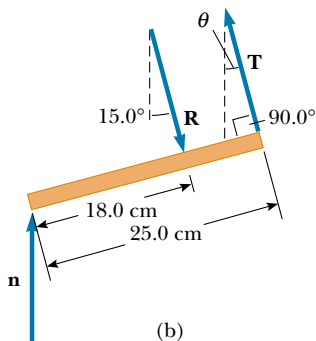

Figure P12.49

50. When a person stands on tiptoe (a strenuous position), the position of the foot is as shown in Figure P12.50a. The total weight of the body F_g is supported by the force \mathbf{n} exerted by the floor on the toe. A mechanical model for the situation is shown in Figure P12.50b,



(a)



(b)

Figure P12.50

where \mathbf{T} is the force exerted by the Achilles tendon on the foot and \mathbf{R} is the force exerted by the tibia on the foot. Find the values of T , R , and θ when $F_g = 700\text{ N}$.

51. A person bends over and lifts a 200-N object as shown in Figure P12.51a, with his back in a horizontal position (a terrible way to lift an object). The back muscle attached at a point two thirds the way up the spine maintains the position of the back, and the angle between the spine and this muscle is 12.0° . Using the mechanical model shown in Figure P12.51b and taking the weight of the upper body to be 350 N, find the tension in the back muscle and the compressional force in the spine.

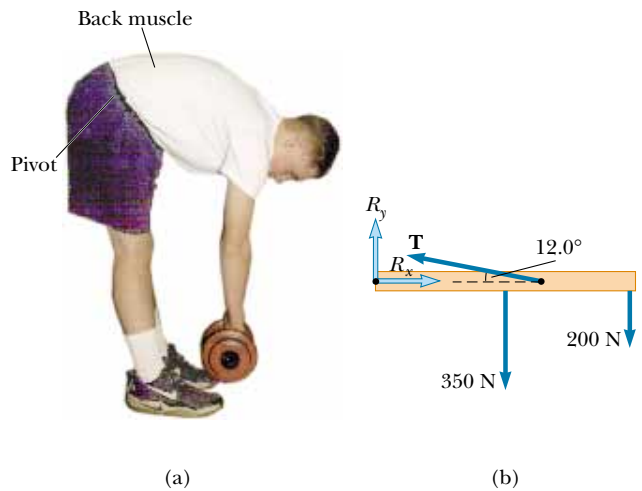

Figure P12.51

52. Two 200-N traffic lights are suspended from a single cable, as shown in Figure 12.52. Neglecting the cable's weight, (a) prove that if $\theta_1 = \theta_2$, then $T_1 = T_2$. (b) Determine the three tensions T_1 , T_2 , and T_3 if $\theta_1 = \theta_2 = 8.00^\circ$.

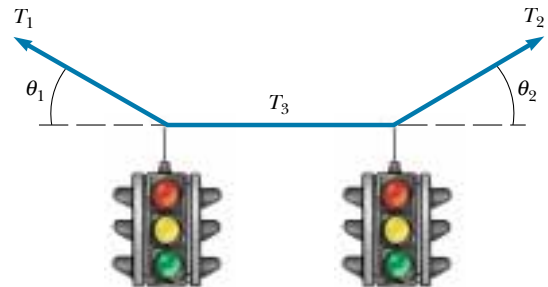

Figure P12.52

53. A force acts on a rectangular cabinet weighing 400 N, as illustrated in Figure P12.53. (a) If the cabinet slides with constant speed when $F = 200\text{ N}$ and $h = 0.400\text{ m}$,

find the coefficient of kinetic friction and the position of the resultant normal force. (b) If $F = 300$ N, find the value of h for which the cabinet just begins to tip.

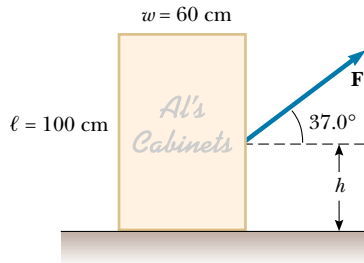

Figure P12.53 Problems 53 and 54.

54. Consider the rectangular cabinet of Problem 53, but with a force \mathbf{F} applied horizontally at its upper edge. (a) What is the minimum force that must be applied for the cabinet to start tipping? (b) What is the minimum coefficient of static friction required to prevent the cabinet from sliding with the application of a force of this magnitude? (c) Find the magnitude and direction of the minimum force required to tip the cabinet if the point of application can be chosen anywhere on it.
55. A uniform rod of weight F_g and length L is supported at its ends by a frictionless trough, as shown in Figure P12.55. (a) Show that the center of gravity of the rod is directly over point O when the rod is in equilibrium. (b) Determine the equilibrium value of the angle θ .

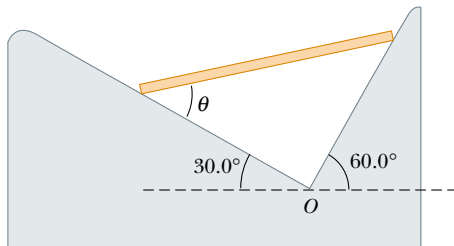

Figure P12.55

56. **Review Problem.** A cue stick strikes a cue ball and delivers a horizontal impulse in such a way that the ball rolls without slipping as it starts to move. At what height above the ball's center (in terms of the radius of the ball) was the blow struck?
57. A uniform beam of mass m is inclined at an angle θ to the horizontal. Its upper end produces a 90° bend in a very rough rope tied to a wall, and its lower end rests on a rough floor (Fig. P12.57). (a) If the coefficient of static friction between the beam and the floor is μ_s , determine an expression for the maximum mass M that can

be suspended from the top before the beam slips. (b) Determine the magnitude of the reaction force at the floor and the magnitude of the force exerted by the beam on the rope at P in terms of m , M , and μ_s .

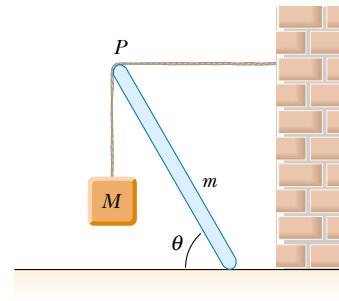

Figure P12.57

58. Figure P12.58 shows a truss that supports a downward force of 1 000 N applied at the point B . The truss has negligible weight. The piers at A and C are smooth. (a) Apply the conditions of equilibrium to prove that $n_A = 366$ N and that $n_C = 634$ N. (b) Show that, because forces act on the light truss only at the hinge joints, each bar of the truss must exert on each hinge pin only a force along the length of that bar—a force of tension or compression. (c) Find the force of tension or compression in each of the three bars.

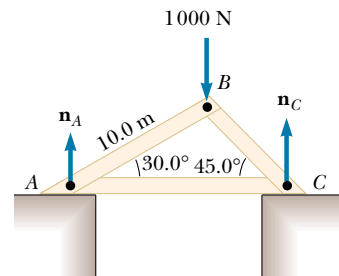

Figure P12.58

59. A stepladder of negligible weight is constructed as shown in Figure P12.59. A painter with a mass of 70.0 kg stands on the ladder 3.00 m from the bottom. Assuming that the floor is frictionless, find (a) the tension in the horizontal bar connecting the two halves of the ladder, (b) the normal forces at A and B , and (c) the components of the reaction force at the single hinge C that the left half of the ladder exerts on the right half. (*Hint:* Treat each half of the ladder separately.)

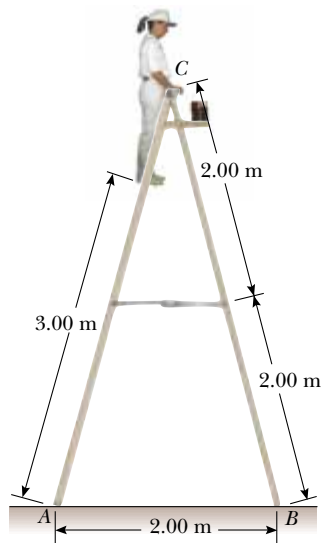

Figure P12.59

60. A flat dance floor of dimensions 20.0 m by 20.0 m has a mass of 1 000 kg. Three dance couples, each of mass 125 kg, start in the top left, top right, and bottom left corners. (a) Where is the initial center of gravity? (b) The couple in the bottom left corner moves 10.0 m to the right. Where is the new center of gravity? (c) What was the average velocity of the center of gravity if it took that couple 8.00 s to change position?
61. A shelf bracket is mounted on a vertical wall by a single screw, as shown in Figure P12.61. Neglecting the weight of the bracket, find the horizontal component of the force that the screw exerts on the bracket when an 80.0-N vertical force is applied as shown. (*Hint:* Imagine that the bracket is slightly loose.)

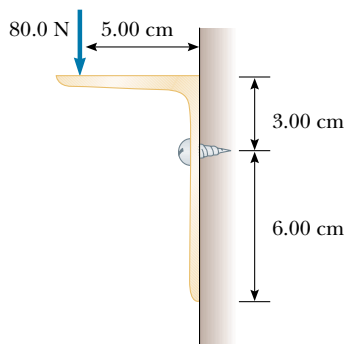

Figure P12.61

62. Figure P12.62 shows a vertical force applied tangentially to a uniform cylinder of weight F_g . The coefficient of

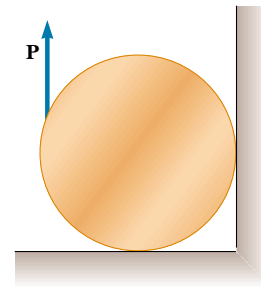

Figure P12.62

static friction between the cylinder and all surfaces is 0.500. In terms of F_g , find the maximum force \mathbf{P} that can be applied that does not cause the cylinder to rotate. (*Hint:* When the cylinder is on the verge of slipping, both friction forces are at their maximum values. Why?)

- WEB 63. **Review Problem.** A wire of length L_i , Young's modulus Y , and cross-sectional area A is stretched elastically by an amount ΔL . According to Hooke's law, the restoring force is $-k \Delta L$. (a) Show that $k = YA/L_i$. (b) Show that the work done in stretching the wire by an amount ΔL is $W = YA(\Delta L)^2/2L_i$.
64. Two racquetballs are placed in a glass jar, as shown in Figure P12.64. Their centers and the point A lie on a straight line. (a) Assuming that the walls are frictionless, determine P_1 , P_2 , and P_3 . (b) Determine the magnitude of the force exerted on the right ball by the left ball. Assume each ball has a mass of 170 g.

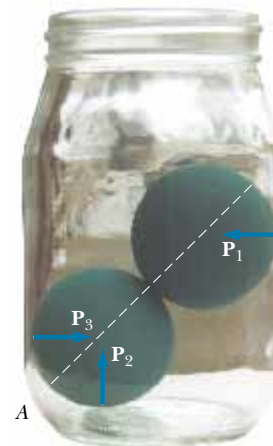

Figure P12.64

65. In Figure P12.65, the scales read $F_{g1} = 380 \text{ N}$ and $F_{g2} = 320 \text{ N}$. Neglecting the weight of the supporting plank,

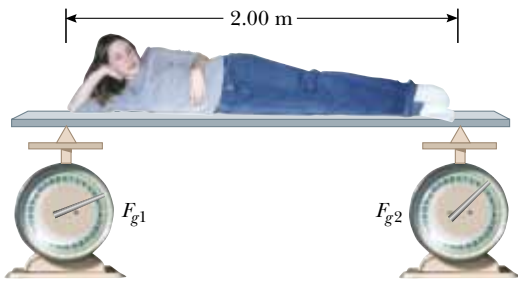

Figure P12.65

how far from the woman's feet is her center of mass, given that her height is 2.00 m?

66. A steel cable 3.00 cm^2 in cross-sectional area has a mass of 2.40 kg per meter of length. If 500 m of the cable is hung over a vertical cliff, how much does the cable stretch under its own weight? (For Young's modulus for steel, refer to Table 12.1.)
67. (a) Estimate the force with which a karate master strikes a board if the hand's speed at time of impact is 10.0 m/s and decreases to 1.00 m/s during a 0.00200-s time-of-contact with the board. The mass of coordinated hand-and-arm is 1.00 kg . (b) Estimate the shear stress if this force is exerted on a 1.00-cm -thick pine board that is 10.0 cm wide. (c) If the maximum shear stress a pine board can receive before breaking is $3.60 \times 10^6 \text{ N/m}^2$, will the board break?
68. A bucket is made from thin sheet metal. The bottom and top of the bucket have radii of 25.0 cm and 35.0 cm , respectively. The bucket is 30.0 cm high and filled with water. Where is the center of gravity? (Ignore the weight of the bucket itself.)
69. **Review Problem.** A trailer with a loaded weight of F_g is being pulled by a vehicle with a force \mathbf{P} , as illustrated in Figure P12.69. The trailer is loaded such that its center of mass is located as shown. Neglect the force of rolling friction and let a represent the x component of the acceleration of the trailer. (a) Find the vertical component of \mathbf{P} in terms of the given parameters. (b) If $a = 2.00 \text{ m/s}^2$ and $h = 1.50 \text{ m}$, what must be the value of d

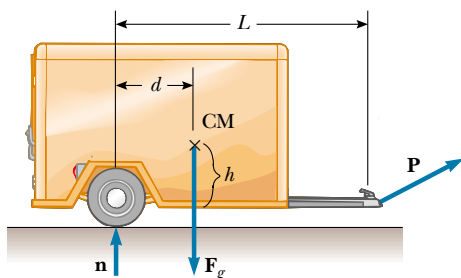

Figure P12.69

so that $P_y = 0$ (that is, no vertical load on the vehicle)? (c) Find the values of P_x and P_y given that $F_g = 1500 \text{ N}$, $d = 0.800 \text{ m}$, $L = 3.00 \text{ m}$, $h = 1.50 \text{ m}$, and $a = -2.00 \text{ m/s}^2$.

70. **Review Problem.** An aluminum wire is 0.850 m long and has a circular cross section of diameter 0.780 mm . Fixed at the top end, the wire supports a 1.20-kg mass that swings in a horizontal circle. Determine the angular velocity required to produce strain 1.00×10^{-3} .
71. A 200-m -long bridge truss extends across a river (Fig. P12.71). Calculate the force of tension or compression in each structural component when a 1360-kg car is at the center of the bridge. Assume that the structure is free to slide horizontally to permit thermal expansion and contraction, that the structural components are connected by pin joints, and that the masses of the structural components are small compared with the mass of the car.

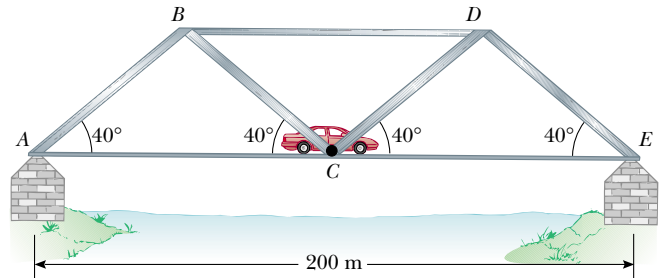

Figure P12.71

72. A 100-m -long bridge truss is supported at its ends so that it can slide freely (Fig. P12.72). A 1500-kg car is halfway between points A and C. Show that the weight of the car is evenly distributed between points A and C, and calculate the force in each structural component. Specify whether each structural component is under tension or compression. Assume that the structural components are connected by pin joints and that the masses of the components are small compared with the mass of the car.

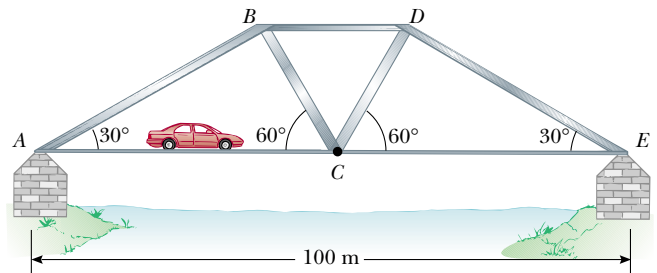

Figure P12.72

ANSWERS TO QUICK QUIZZES

- 12.1** (a) Yes, as Figure 12.3 shows. The unbalanced torques cause an angular acceleration even though the linear acceleration is zero. (b) Yes, again. This happens when the lines of action of all the forces intersect at a common point. If a net force acts on the object, then the object has a translational acceleration. However, because there is no net torque on the object, the object has no angular acceleration. There are other instances in which torques cancel but the forces do not. You should be able to draw at least two.
- 12.2** The location of the board's center of gravity relative to the fulcrum.
- 12.3** Young's modulus is given by the ratio of stress to strain, which is the slope of the elastic behavior section of the graph in Figure 12.14. Reading from the graph, we note that a stress of approximately $3 \times 10^8 \text{ N/m}^2$ results in a strain of 0.003. The slope, and hence Young's modulus, are therefore $10 \times 10^{10} \text{ N/m}^2$.
- 12.4** A substantial part of the graph extends beyond the elastic limit, indicating permanent deformation. Thus, the material is ductile.