

PUZZLER

If all these appliances were operating at one time, a circuit breaker would probably be tripped, preventing a potentially dangerous situation. What causes a circuit breaker to trip when too many electrical devices are plugged into one circuit? (George Semple)



chapter

28

Direct Current Circuits

Chapter Outline

28.1 Electromotive Force

28.2 Resistors in Series and in Parallel

28.3 Kirchhoff's Rules

28.4 *RC* Circuits

28.5 (Optional) Electrical Instruments

28.6 (Optional) Household Wiring and Electrical Safety

This chapter is concerned with the analysis of some simple electric circuits that contain batteries, resistors, and capacitors in various combinations. The analysis of these circuits is simplified by the use of two rules known as *Kirchhoff's rules*, which follow from the laws of conservation of energy and conservation of electric charge. Most of the circuits analyzed are assumed to be in *steady state*, which means that the currents are constant in magnitude and direction. In Section 28.4 we discuss circuits in which the current varies with time. Finally, we describe a variety of common electrical devices and techniques for measuring current, potential difference, resistance, and emf.

28.1 ELECTROMOTIVE FORCE

In Section 27.6 we found that a constant current can be maintained in a closed circuit through the use of a source of *emf*, which is a device (such as a battery or generator) that produces an electric field and thus may cause charges to move around a circuit. One can think of a source of emf as a “charge pump.” When an electric potential difference exists between two points, the source moves charges “uphill” from the lower potential to the higher. The emf \mathcal{E} describes the work done per unit charge, and hence the SI unit of emf is the volt.

Consider the circuit shown in Figure 28.1, consisting of a battery connected to a resistor. We assume that the connecting wires have no resistance. The positive terminal of the battery is at a higher potential than the negative terminal. If we neglect the internal resistance of the battery, the potential difference across it (called the *terminal voltage*) equals its emf. However, because a real battery always has some internal resistance r , the terminal voltage is not equal to the emf for a battery in a circuit in which there is a current. To understand why this is so, consider the circuit diagram in Figure 28.2a, where the battery of Figure 28.1 is represented by the dashed rectangle containing an emf \mathcal{E} in series with an internal resistance r . Now imagine moving through the battery clockwise from a to b and measuring the electric potential at various locations. As we pass from the negative terminal to the positive terminal, the potential *increases* by an amount \mathcal{E} . However, as we move through the resistance r , the potential *decreases* by an amount Ir , where I is the current in the circuit. Thus, the terminal voltage of the battery $\Delta V = V_b - V_a$ is¹

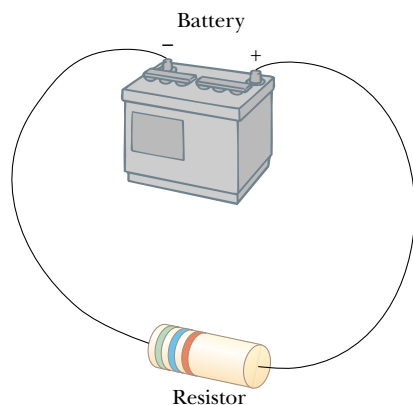

Figure 28.1 A circuit consisting of a resistor connected to the terminals of a battery.

¹ The terminal voltage in this case is less than the emf by an amount Ir . In some situations, the terminal voltage may *exceed* the emf by an amount Ir . This happens when the direction of the current is *opposite* that of the emf, as in the case of charging a battery with another source of emf.

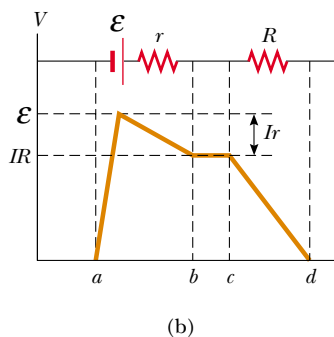
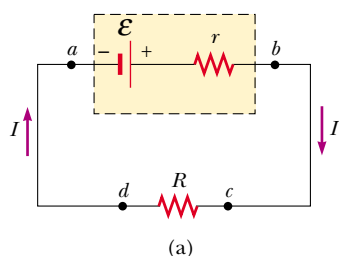

Figure 28.2 (a) Circuit diagram of a source of emf \mathcal{E} (in this case, a battery), of internal resistance r , connected to an external resistor of resistance R . (b) Graphical representation showing how the electric potential changes as the circuit in part (a) is traversed clockwise.

$$\Delta V = \mathcal{E} - Ir \quad (28.1)$$

From this expression, note that \mathcal{E} is equivalent to the **open-circuit voltage**—that is, the *terminal voltage when the current is zero*. The emf is the voltage labeled on a battery—for example, the emf of a D cell is 1.5 V. The actual potential difference between the terminals of the battery depends on the current through the battery, as described by Equation 28.1.

Figure 28.2b is a graphical representation of the changes in electric potential as the circuit is traversed in the clockwise direction. By inspecting Figure 28.2a, we see that the terminal voltage ΔV must equal the potential difference across the external resistance R , often called the **load resistance**. The load resistor might be a simple resistive circuit element, as in Figure 28.1, or it could be the resistance of some electrical device (such as a toaster, an electric heater, or a lightbulb) connected to the battery (or, in the case of household devices, to the wall outlet). The resistor represents a *load* on the battery because the battery must supply energy to operate the device. The potential difference across the load resistance is $\Delta V = IR$. Combining this expression with Equation 28.1, we see that

$$\mathcal{E} = IR + Ir \quad (28.2)$$

Solving for the current gives

$$I = \frac{\mathcal{E}}{R + r} \quad (28.3)$$

This equation shows that the current in this simple circuit depends on both the load resistance R external to the battery and the internal resistance r . If R is much greater than r , as it is in many real-world circuits, we can neglect r .

If we multiply Equation 28.2 by the current I , we obtain

$$I\mathcal{E} = I^2R + I^2r \quad (28.4)$$

This equation indicates that, because power $\mathcal{P} = I\Delta V$ (see Eq. 27.22), the total power output $I\mathcal{E}$ of the battery is delivered to the external load resistance in the amount I^2R and to the internal resistance in the amount I^2r . Again, if $r \ll R$, then most of the power delivered by the battery is transferred to the load resistance.

EXAMPLE 28.1 Terminal Voltage of a Battery

A battery has an emf of 12.0 V and an internal resistance of 0.05 Ω . Its terminals are connected to a load resistance of 3.00 Ω . (a) Find the current in the circuit and the terminal voltage of the battery.

Solution Using first Equation 28.3 and then Equation 28.1, we obtain

$$I = \frac{\mathcal{E}}{R + r} = \frac{12.0 \text{ V}}{3.05 \Omega} = 3.93 \text{ A}$$

$$\Delta V = \mathcal{E} - Ir = 12.0 \text{ V} - (3.93 \text{ A})(0.05 \Omega) = 11.8 \text{ V}$$

To check this result, we can calculate the voltage across the load resistance R :

$$\Delta V = IR = (3.93 \text{ A})(3.00 \Omega) = 11.8 \text{ V}$$

(b) Calculate the power delivered to the load resistor, the power delivered to the internal resistance of the battery, and the power delivered by the battery.

Solution The power delivered to the load resistor is

$$\mathcal{P}_R = I^2R = (3.93 \text{ A})^2 (3.00 \Omega) = 46.3 \text{ W}$$

The power delivered to the internal resistance is

$$\mathcal{P}_r = I^2r = (3.93 \text{ A})^2 (0.05 \Omega) = 0.772 \text{ W}$$

Hence, the power delivered by the battery is the sum of these quantities, or 47.1 W. You should check this result, using the expression $\mathcal{P} = I\mathcal{E}$.

EXAMPLE 28.2 Matching the Load

Show that the maximum power delivered to the load resistance R in Figure 28.2a occurs when the load resistance matches the internal resistance—that is, when $R = r$.

Solution The power delivered to the load resistance is equal to I^2R , where I is given by Equation 28.3:

$$\mathcal{P} = I^2R = \frac{\mathcal{E}^2R}{(R + r)^2}$$

When \mathcal{P} is plotted versus R as in Figure 28.3, we find that \mathcal{P} reaches a maximum value of $\mathcal{E}^2/4r$ at $R = r$. We can also prove this by differentiating \mathcal{P} with respect to R , setting the result equal to zero, and solving for R . The details are left as a problem for you to solve (Problem 57).

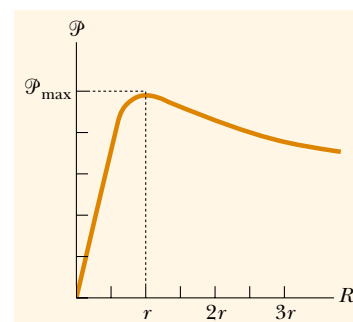

Figure 28.3 Graph of the power \mathcal{P} delivered by a battery to a load resistor of resistance R as a function of R . The power delivered to the resistor is a maximum when the load resistance equals the internal resistance of the battery.

28.2 RESISTORS IN SERIES AND IN PARALLEL

Suppose that you and your friends are at a crowded basketball game in a sports arena and decide to leave early. You have two choices: (1) your whole group can exit through a single door and walk down a long hallway containing several concession stands, each surrounded by a large crowd of people waiting to buy food or souvenirs; or (2) each member of your group can exit through a separate door in the main hall of the arena, where each will have to push his or her way through a single group of people standing by the door. In which scenario will less time be required for your group to leave the arena?

It should be clear that your group will be able to leave faster through the separate doors than down the hallway where each of you has to push through several groups of people. We could describe the groups of people in the hallway as acting in *series*, because each of you must push your way through all of the groups. The groups of people around the doors in the arena can be described as acting in *parallel*. Each member of your group must push through only one group of people, and each member pushes through a *different* group of people. This simple analogy will help us understand the behavior of currents in electric circuits containing more than one resistor.

When two or more resistors are connected together as are the lightbulbs in Figure 28.4a, they are said to be in *series*. Figure 28.4b is the circuit diagram for the lightbulbs, which are shown as resistors, and the battery. In a series connection, all the charges moving through one resistor must also pass through the second resistor. (This is analogous to all members of your group pushing through the crowds in the single hallway of the sports arena.) Otherwise, charge would accumulate between the resistors. Thus,

for a series combination of resistors, the currents in the two resistors are the same because any charge that passes through R_1 must also pass through R_2 .

The potential difference applied across the series combination of resistors will divide between the resistors. In Figure 28.4b, because the voltage drop² from a to b

² The term *voltage drop* is synonymous with a decrease in electric potential across a resistor and is used often by individuals working with electric circuits.

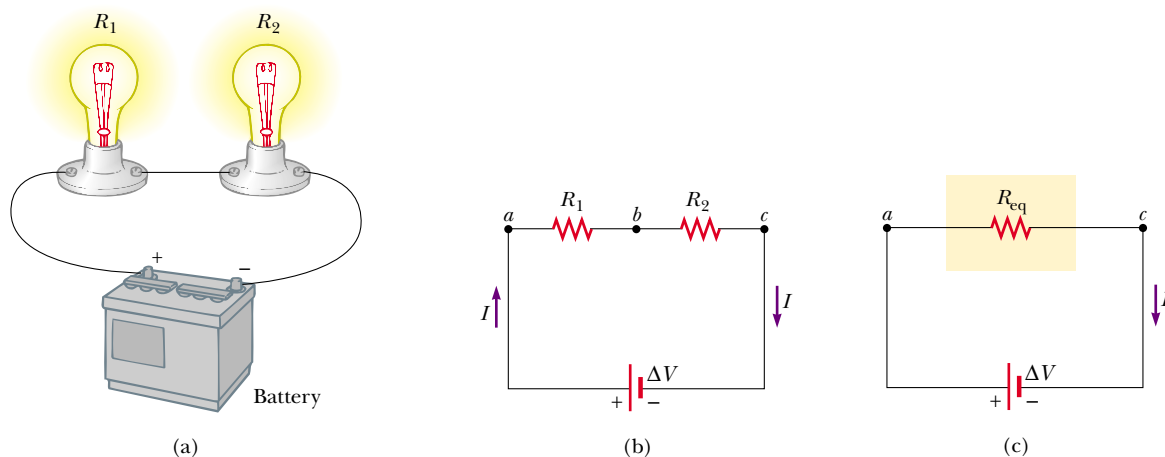

Figure 28.4 (a) A series connection of two resistors R_1 and R_2 . The current in R_1 is the same as that in R_2 . (b) Circuit diagram for the two-resistor circuit. (c) The resistors replaced with a single resistor having an equivalent resistance $R_{\text{eq}} = R_1 + R_2$.

equals IR_1 and the voltage drop from b to c equals IR_2 , the voltage drop from a to c is

$$\Delta V = IR_1 + IR_2 = I(R_1 + R_2)$$

Therefore, we can replace the two resistors in series with a single resistor having an *equivalent resistance* R_{eq} , where

$$R_{\text{eq}} = R_1 + R_2 \quad (28.5)$$

The resistance R_{eq} is equivalent to the series combination $R_1 + R_2$ in the sense that the circuit current is unchanged when R_{eq} replaces $R_1 + R_2$.

The equivalent resistance of three or more resistors connected in series is

$$R_{\text{eq}} = R_1 + R_2 + R_3 + \cdots \quad (28.6)$$

This relationship indicates that **the equivalent resistance of a series connection of resistors is always greater than any individual resistance.**

Quick Quiz 28.1

If a piece of wire is used to connect points b and c in Figure 28.4b, does the brightness of bulb R_1 increase, decrease, or stay the same? What happens to the brightness of bulb R_2 ?

Now consider two resistors connected in *parallel*, as shown in Figure 28.5. When the current I reaches point a in Figure 28.5b, called a *junction*, it splits into two parts, with I_1 going through R_1 and I_2 going through R_2 . A **junction** is any point in a circuit where a current can split (just as your group might split up and leave the arena through several doors, as described earlier.) This split results in less current in each individual resistor than the current leaving the battery. Because charge must be conserved, the current I that enters point a must equal the total current leaving that point:

$$I = I_1 + I_2$$



A series connection of three light-bulbs, all rated at 120 V but having power ratings of 60 W, 75 W, and 200 W. Why are the intensities of the bulbs different? Which bulb has the greatest resistance? How would their relative intensities differ if they were connected in parallel?

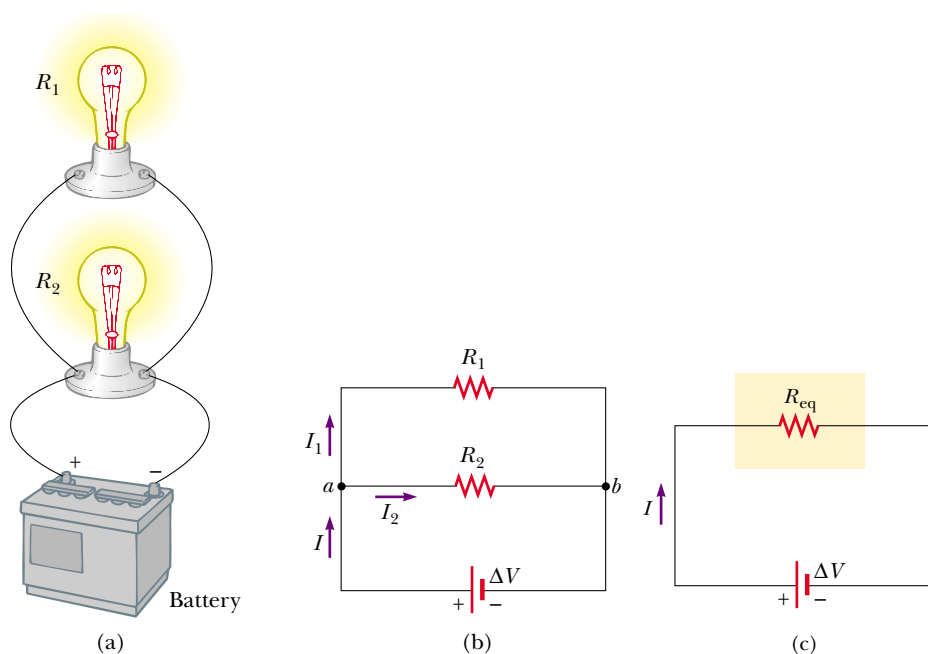

Figure 28.5 (a) A parallel connection of two resistors R_1 and R_2 . The potential difference across R_1 is the same as that across R_2 . (b) Circuit diagram for the two-resistor circuit. (c) The resistors replaced with a single resistor having an equivalent resistance $R_{\text{eq}} = (R_1^{-1} + R_2^{-1})^{-1}$.

As can be seen from Figure 28.5, both resistors are connected directly across the terminals of the battery. Thus,

when resistors are connected in parallel, the potential differences across them are the same.

Because the potential differences across the resistors are the same, the expression $\Delta V = IR$ gives

$$I = I_1 + I_2 = \frac{\Delta V}{R_1} + \frac{\Delta V}{R_2} = \Delta V \left(\frac{1}{R_1} + \frac{1}{R_2} \right) = \frac{\Delta V}{R_{\text{eq}}}$$

From this result, we see that the equivalent resistance of two resistors in parallel is given by

$$\frac{1}{R_{\text{eq}}} = \frac{1}{R_1} + \frac{1}{R_2} \quad (28.7)$$

or

$$R_{\text{eq}} = \frac{1}{\frac{1}{R_1} + \frac{1}{R_2}}$$

An extension of this analysis to three or more resistors in parallel gives

$$\frac{1}{R_{\text{eq}}} = \frac{1}{R_1} + \frac{1}{R_2} + \frac{1}{R_3} + \dots \quad (28.8)$$

QuickLab

Tape one pair of drinking straws end to end, and tape a second pair side by side. Which pair is easier to blow through? What would happen if you were comparing three straws taped end to end with three taped side by side?

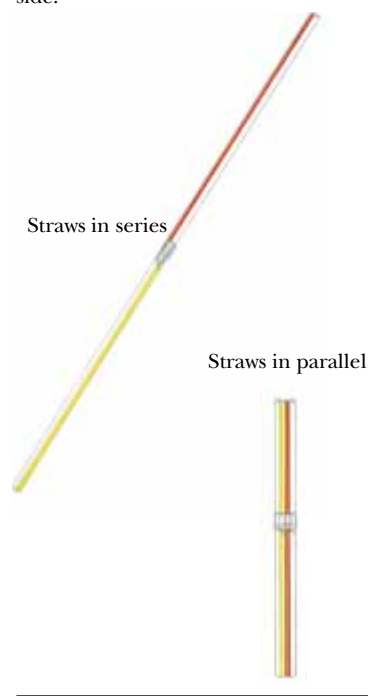

The equivalent resistance of several resistors in parallel



Three lightbulbs having power ratings of 25 W, 75 W, and 150 W, connected in parallel to a voltage source of about 100 V. All bulbs are rated at the same voltage. Why do the intensities differ? Which bulb draws the most current? Which has the least resistance?

We can see from this expression that **the equivalent resistance of two or more resistors connected in parallel is always less than the least resistance in the group.**

Household circuits are always wired such that the appliances are connected in parallel. Each device operates independently of the others so that if one is switched off, the others remain on. In addition, the devices operate on the same voltage.

Quick Quiz 28.2

Assume that the battery of Figure 28.1 has zero internal resistance. If we add a second resistor in series with the first, does the current in the battery increase, decrease, or stay the same? How about the potential difference across the battery terminals? Would your answers change if the second resistor were connected in parallel to the first one?

Quick Quiz 28.3

Are automobile headlights wired in series or in parallel? How can you tell?

EXAMPLE 28.3 Find the Equivalent Resistance

Four resistors are connected as shown in Figure 28.6a. (a) Find the equivalent resistance between points a and c .

Solution The combination of resistors can be reduced in steps, as shown in Figure 28.6. The $8.0\text{-}\Omega$ and $4.0\text{-}\Omega$ resistors are in series; thus, the equivalent resistance between a and b is $12\ \Omega$ (see Eq. 28.5). The $6.0\text{-}\Omega$ and $3.0\text{-}\Omega$ resistors are in parallel, so from Equation 28.7 we find that the equivalent resistance from b to c is $2.0\ \Omega$. Hence, the equivalent resistance from a to c is $14\ \Omega$.

(b) What is the current in each resistor if a potential difference of 42 V is maintained between a and c ?

Solution The currents in the $8.0\text{-}\Omega$ and $4.0\text{-}\Omega$ resistors are the same because they are in series. In addition, this is the same as the current that would exist in the $14\text{-}\Omega$ equivalent resistor subject to the 42-V potential difference. Therefore, using Equation 27.8 ($R = \Delta V/I$) and the results from part (a), we obtain

$$I = \frac{\Delta V_{ac}}{R_{\text{eq}}} = \frac{42\ \text{V}}{14\ \Omega} = 3.0\ \text{A}$$

This is the current in the $8.0\text{-}\Omega$ and $4.0\text{-}\Omega$ resistors. When this 3.0-A current enters the junction at b , however, it splits, with part passing through the $6.0\text{-}\Omega$ resistor (I_1) and part through the $3.0\text{-}\Omega$ resistor (I_2). Because the potential difference is ΔV_{bc} across each of these resistors (since they are in parallel), we see that $(6.0\ \Omega)I_1 = (3.0\ \Omega)I_2$, or $I_2 = 2I_1$. Using this result and the fact that $I_1 + I_2 = 3.0\ \text{A}$, we find that $I_1 = 1.0\ \text{A}$ and

$I_2 = 2.0\ \text{A}$. We could have guessed this at the start by noting that the current through the $3.0\text{-}\Omega$ resistor has to be twice that through the $6.0\text{-}\Omega$ resistor, in view of their relative resistances and the fact that the same voltage is applied to each of them.

As a final check of our results, note that $\Delta V_{bc} = (6.0\ \Omega)I_1 = (3.0\ \Omega)I_2 = 6.0\ \text{V}$ and $\Delta V_{ab} = (12\ \Omega)I = 36\ \text{V}$; therefore, $\Delta V_{ac} = \Delta V_{ab} + \Delta V_{bc} = 42\ \text{V}$, as it must.

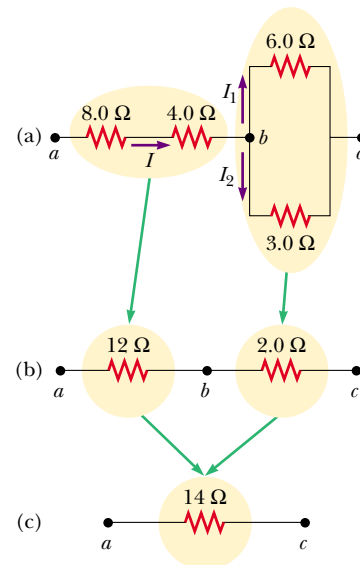

Figure 28.6

EXAMPLE 28.4 Three Resistors in Parallel

Three resistors are connected in parallel as shown in Figure 28.7. A potential difference of 18 V is maintained between points a and b . (a) Find the current in each resistor.

Solution The resistors are in parallel, and so the potential difference across each must be 18 V. Applying the relationship $\Delta V = IR$ to each resistor gives

$$I_1 = \frac{\Delta V}{R_1} = \frac{18 \text{ V}}{3.0 \Omega} = 6.0 \text{ A}$$

$$I_2 = \frac{\Delta V}{R_2} = \frac{18 \text{ V}}{6.0 \Omega} = 3.0 \text{ A}$$

$$I_3 = \frac{\Delta V}{R_3} = \frac{18 \text{ V}}{9.0 \Omega} = 2.0 \text{ A}$$

(b) Calculate the power delivered to each resistor and the total power delivered to the combination of resistors.

Solution We apply the relationship $\mathcal{P} = (\Delta V)^2/R$ to each resistor and obtain

$$\mathcal{P}_1 = \frac{\Delta V^2}{R_1} = \frac{(18 \text{ V})^2}{3.0 \Omega} = 110 \text{ W}$$

$$\mathcal{P}_2 = \frac{\Delta V^2}{R_2} = \frac{(18 \text{ V})^2}{6.0 \Omega} = 54 \text{ W}$$

$$\mathcal{P}_3 = \frac{\Delta V^2}{R_3} = \frac{(18 \text{ V})^2}{9.0 \Omega} = 36 \text{ W}$$

This shows that the smallest resistor receives the most power. Summing the three quantities gives a total power of 200 W.

(c) Calculate the equivalent resistance of the circuit.

Solution We can use Equation 28.8 to find R_{eq} :

$$\begin{aligned} \frac{1}{R_{\text{eq}}} &= \frac{1}{3.0 \Omega} + \frac{1}{6.0 \Omega} + \frac{1}{9.0 \Omega} \\ &= \frac{6}{18 \Omega} + \frac{3}{18 \Omega} + \frac{2}{18 \Omega} = \frac{11}{18 \Omega} \end{aligned}$$

$$R_{\text{eq}} = \frac{18 \Omega}{11} = 1.6 \Omega$$

Exercise Use R_{eq} to calculate the total power delivered by the battery.

Answer 200 W.

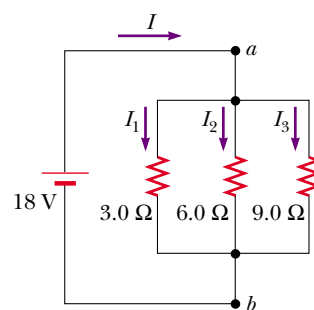

Figure 28.7 Three resistors connected in parallel. The voltage across each resistor is 18 V.

EXAMPLE 28.5 Finding R_{eq} by Symmetry Arguments

Consider five resistors connected as shown in Figure 28.8a. Find the equivalent resistance between points a and b .

Solution In this type of problem, it is convenient to assume a current entering junction a and then apply symmetry

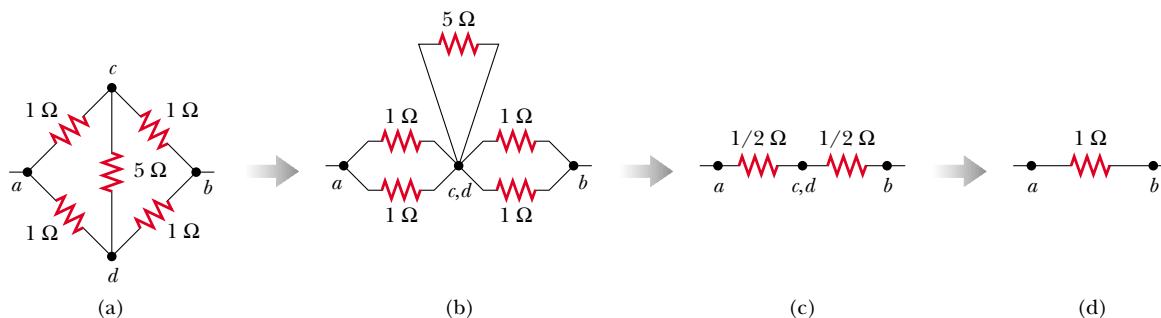

Figure 28.8 Because of the symmetry in this circuit, the 5- Ω resistor does not contribute to the resistance between points a and b and therefore can be disregarded when we calculate the equivalent resistance.

arguments. Because of the symmetry in the circuit (all $1\text{-}\Omega$ resistors in the outside loop), the currents in branches ac and ad must be equal; hence, the electric potentials at points c and d must be equal. This means that $\Delta V_{cd} = 0$ and, as a result, points c and d may be connected together without affecting the circuit, as in Figure 28.8b. Thus, the $5\text{-}\Omega$ resistor may

be removed from the circuit and the remaining circuit then reduced as in Figures 28.8c and d. From this reduction we see that the equivalent resistance of the combination is $1\text{ }\Omega$. Note that the result is $1\text{ }\Omega$ regardless of the value of the resistor connected between c and d .

CONCEPTUAL EXAMPLE 28.6 Operation of a Three-Way Lightbulb

Figure 28.9 illustrates how a three-way lightbulb is constructed to provide three levels of light intensity. The socket of the lamp is equipped with a three-way switch for selecting different light intensities. The bulb contains two filaments. When the lamp is connected to a 120-V source, one filament receives 100 W of power, and the other receives 75 W . Explain how the two filaments are used to provide three different light intensities.

Solution The three light intensities are made possible by applying the 120 V to one filament alone, to the other filament alone, or to the two filaments in parallel. When switch S_1 is closed and switch S_2 is opened, current passes only through the 75-W filament. When switch S_1 is open and switch S_2 is closed, current passes only through the 100-W filament. When both switches are closed, current passes through both filaments, and the total power is 175 W .

If the filaments were connected in series and one of them were to break, no current could pass through the bulb, and the bulb would give no illumination, regardless of the switch position. However, with the filaments connected in parallel, if one of them (for example, the 75-W filament) breaks, the bulb will still operate in two of the switch positions as current passes through the other (100-W) filament.

Exercise Determine the resistances of the two filaments and their parallel equivalent resistance.

Answer $144\text{ }\Omega$, $192\text{ }\Omega$, $82.3\text{ }\Omega$.

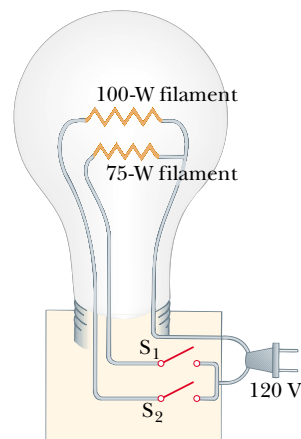

Figure 28.9 A three-way lightbulb.

APPLICATION Strings of Lights

Strings of lights are used for many ornamental purposes, such as decorating Christmas trees. Over the years, both parallel and series connections have been used for multilight strings powered by 120 V .³ Series-wired bulbs are safer than parallel-wired bulbs for indoor Christmas-tree use because series-wired bulbs operate with less light per bulb and at a lower temperature. However, if the filament of a single bulb fails (or if the bulb is removed from its socket), all the lights on the string are extinguished. The popularity of series-wired light strings diminished because troubleshooting a failed bulb was a tedious, time-consuming chore that involved trial-and-error substitution of a good bulb in each socket along the string until the defective bulb was found.

In a parallel-wired string, each bulb operates at 120 V . By design, the bulbs are brighter and hotter than those on a series-wired string. As a result, these bulbs are inherently more dangerous (more likely to start a fire, for instance), but if one bulb in a parallel-wired string fails or is removed, the rest of the bulbs continue to glow. (A 25-bulb string of 4-W bulbs results in a power of 100 W ; the total power becomes substantial when several strings are used.)

A new design was developed for so-called “miniature” lights wired in series, to prevent the failure of one bulb from extinguishing the entire string. The solution is to create a connection (called a jumper) across the filament after it fails. (If an alternate connection existed across the filament before

³ These and other household devices, such as the three-way lightbulb in Conceptual Example 28.6 and the kitchen appliances shown in this chapter’s Puzzler, actually operate on alternating current (ac), to be introduced in Chapter 33.

it failed, each bulb would represent a parallel circuit; in this circuit, the current would flow through the alternate connection, forming a short circuit, and the bulb would not glow.) When the filament breaks in one of these miniature lightbulbs, 120 V appears across the bulb because no current is present in the bulb and therefore no drop in potential occurs across the other bulbs. Inside the lightbulb, a small loop covered by an insulating material is wrapped around the filament leads. An arc burns the insulation and connects the filament leads when 120 V appears across the bulb—that is, when the filament fails. This “short” now completes the circuit through the bulb even though the filament is no longer active (Fig. 28.10).

Suppose that all the bulbs in a 50-bulb miniature-light string are operating. A 2.4-V potential drop occurs across each bulb because the bulbs are in series. The power input to this style of bulb is 0.34 W, so the total power supplied to the string is only 17 W. We calculate the filament resistance at the operating temperature to be $(2.4 \text{ V})^2 / (0.34 \text{ W}) = 17 \Omega$. When the bulb fails, the resistance across its terminals is reduced to zero because of the alternate jumper connection mentioned in the preceding paragraph. All the other bulbs not only stay on but glow more brightly because the total resistance of the string is reduced and consequently the current in each bulb increases.

Let us assume that the operating resistance of a bulb remains at 17Ω even though its temperature rises as a result of the increased current. If one bulb fails, the potential drop across each of the remaining bulbs increases to 2.45 V, the current increases from 0.142 A to 0.145 A, and the power increases to 0.354 W. As more lights fail, the current keeps rising, the filament of each bulb operates at a higher temperature, and the lifetime of the bulb is reduced. It is therefore a good idea to check for failed (nonglowing) bulbs in such a series-wired string and replace them as soon as possible, in order to maximize the lifetimes of all the bulbs.

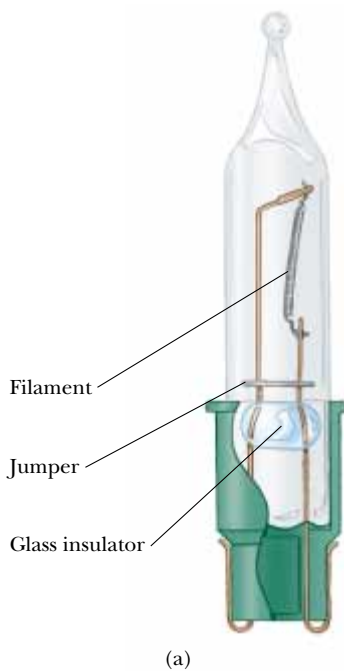

Figure 28.10 (a) Schematic diagram of a modern “miniature” holiday lightbulb, with a jumper connection to provide a current path if the filament breaks. (b) A Christmas-tree lightbulb.

28.3 KIRCHHOFF'S RULES

13.4 As we saw in the preceding section, we can analyze simple circuits using the expression $\Delta V = IR$ and the rules for series and parallel combinations of resistors. Very often, however, it is not possible to reduce a circuit to a single loop. The procedure for analyzing more complex circuits is greatly simplified if we use two principles called **Kirchhoff's rules**:

1. The sum of the currents entering any junction in a circuit must equal the sum of the currents leaving that junction:

$$\sum I_{\text{in}} = \sum I_{\text{out}} \quad (28.9)$$

Gustav Kirchhoff (1824–1887)

Kirchhoff, a professor at Heidelberg, Germany, and Robert Bunsen invented the spectroscope and founded the science of spectroscopy, which we shall study in Chapter 40. They discovered the elements cesium and rubidium and invented astronomical spectroscopy. Kirchhoff formulated another Kirchhoff's rule, namely, "a cool substance will absorb light of the same wavelengths that it emits when hot." (AIP ESVA/W. F. Meggers Collection)

QuickLab

Draw an arbitrarily shaped closed loop that does not cross over itself. Label five points on the loop a , b , c , d , and e , and assign a random number to each point. Now start at a and work your way around the loop, calculating the difference between each pair of adjacent numbers. Some of these differences will be positive, and some will be negative. Add the differences together, making sure you accurately keep track of the algebraic signs. What is the sum of the differences all the way around the loop?

2. The sum of the potential differences across all elements around any closed circuit loop must be zero:

$$\sum_{\text{closed loop}} \Delta V = 0 \quad (28.10)$$

Kirchhoff's first rule is a statement of conservation of electric charge. All current that enters a given point in a circuit must leave that point because charge cannot build up at a point. If we apply this rule to the junction shown in Figure 28.11a, we obtain

$$I_1 = I_2 + I_3$$

Figure 28.11b represents a mechanical analog of this situation, in which water flows through a branched pipe having no leaks. The flow rate into the pipe equals the total flow rate out of the two branches on the right.

Kirchhoff's second rule follows from the law of conservation of energy. Let us imagine moving a charge around the loop. When the charge returns to the starting point, the charge–circuit system must have the same energy as when the charge started from it. The sum of the increases in energy in some circuit elements must equal the sum of the decreases in energy in other elements. The potential energy decreases whenever the charge moves through a potential drop $-IR$ across a resistor or whenever it moves in the reverse direction through a source of emf. The potential energy increases whenever the charge passes through a battery from the negative terminal to the positive terminal. Kirchhoff's second rule applies only for circuits in which an electric potential is defined at each point; this criterion may not be satisfied if changing electromagnetic fields are present, as we shall see in Chapter 31.

In justifying our claim that Kirchhoff's second rule is a statement of conservation of energy, we imagined carrying a charge around a loop. When applying this rule, we imagine *traveling* around the loop and consider changes in *electric potential*, rather than the changes in *potential energy* described in the previous paragraph. You should note the following sign conventions when using the second rule:

- Because charges move from the high-potential end of a resistor to the low-potential end, if a resistor is traversed in the direction of the current, the change in potential ΔV across the resistor is $-IR$ (Fig. 28.12a).
- If a resistor is traversed in the direction *opposite* the current, the change in potential ΔV across the resistor is $+IR$ (Fig. 28.12b).
- If a source of emf (assumed to have zero internal resistance) is traversed in the direction of the emf (from $-$ to $+$), the change in potential ΔV is $+\mathcal{E}$ (Fig. 28.12c). The emf of the battery increases the electric potential as we move through it in this direction.
- If a source of emf (assumed to have zero internal resistance) is traversed in the direction opposite the emf (from $+$ to $-$), the change in potential ΔV is $-\mathcal{E}$ (Fig. 28.12d). In this case the emf of the battery reduces the electric potential as we move through it.

Limitations exist on the numbers of times you can usefully apply Kirchhoff's rules in analyzing a given circuit. You can use the junction rule as often as you need, so long as each time you write an equation you include in it a current that has not been used in a preceding junction-rule equation. In general, the number of times you can use the junction rule is one fewer than the number of junction

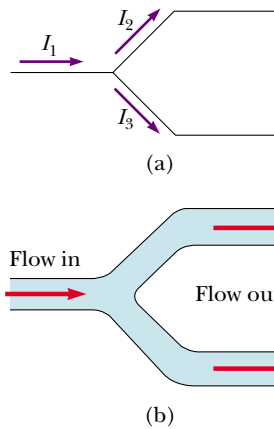

Figure 28.11 (a) Kirchhoff's junction rule. Conservation of charge requires that all current entering a junction must leave that junction. Therefore, $I_1 = I_2 + I_3$. (b) A mechanical analog of the junction rule: the amount of water flowing out of the branches on the right must equal the amount flowing into the single branch on the left.

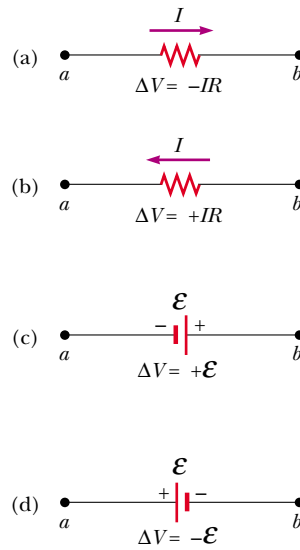

Figure 28.12 Rules for determining the potential changes across a resistor and a battery. (The battery is assumed to have no internal resistance.) Each circuit element is traversed from left to right.

points in the circuit. You can apply the loop rule as often as needed, so long as a new circuit element (resistor or battery) or a new current appears in each new equation. In general, **in order to solve a particular circuit problem, the number of independent equations you need to obtain from the two rules equals the number of unknown currents.**

Complex networks containing many loops and junctions generate great numbers of independent linear equations and a correspondingly great number of unknowns. Such situations can be handled formally through the use of matrix algebra. Computer programs can also be written to solve for the unknowns.

The following examples illustrate how to use Kirchhoff's rules. In all cases, it is assumed that the circuits have reached steady-state conditions—that is, the currents in the various branches are constant. Any capacitor **acts as an open circuit**; that is, the current in the branch containing the capacitor is zero under steady-state conditions.

Problem-Solving Hints

Kirchhoff's Rules

- Draw a circuit diagram, and label all the known and unknown quantities. You must assign a *direction* to the current in each branch of the circuit. Do not be alarmed if you guess the direction of a current incorrectly; your result will be negative, but *its magnitude will be correct*. Although the assignment of current directions is arbitrary, you must adhere rigorously to the assigned directions when applying Kirchhoff's rules.
- Apply the junction rule to any junctions in the circuit that provide new relationships among the various currents.

- Apply the loop rule to as many loops in the circuit as are needed to solve for the unknowns. To apply this rule, you must correctly identify the change in potential as you imagine crossing each element in traversing the closed loop (either clockwise or counterclockwise). Watch out for errors in sign!
- Solve the equations simultaneously for the unknown quantities.

EXAMPLE 28.7 A Single-Loop Circuit

A single-loop circuit contains two resistors and two batteries, as shown in Figure 28.13. (Neglect the internal resistances of the batteries.) (a) Find the current in the circuit.

Solution We do not need Kirchhoff's rules to analyze this simple circuit, but let us use them anyway just to see how they are applied. There are no junctions in this single-loop circuit; thus, the current is the same in all elements. Let us assume that the current is clockwise, as shown in Figure 28.13. Traversing the circuit in the clockwise direction, starting at a , we see that $a \rightarrow b$ represents a potential change of $+\mathcal{E}_1$, $b \rightarrow c$ represents a potential change of $-IR_1$, $c \rightarrow d$ represents a potential change of $-\mathcal{E}_2$, and $d \rightarrow a$ represents a potential change of $-IR_2$. Applying Kirchhoff's loop rule gives

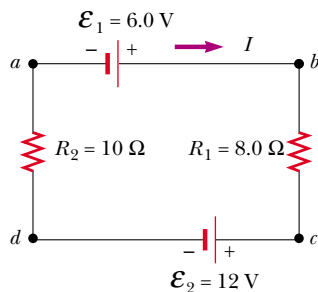

Figure 28.13 A series circuit containing two batteries and two resistors, where the polarities of the batteries are in opposition.

$$\sum \Delta V = 0$$

$$\mathcal{E}_1 - IR_1 - \mathcal{E}_2 - IR_2 = 0$$

Solving for I and using the values given in Figure 28.13, we obtain

$$I = \frac{\mathcal{E}_1 - \mathcal{E}_2}{R_1 + R_2} = \frac{6.0 \text{ V} - 12 \text{ V}}{8.0 \Omega + 10 \Omega} = -0.33 \text{ A}$$

The negative sign for I indicates that the direction of the current is opposite the assumed direction.

(b) What power is delivered to each resistor? What power is delivered by the 12-V battery?

Solution

$$\mathcal{P}_1 = I^2 R_1 = (0.33 \text{ A})^2 (8.0 \Omega) = 0.87 \text{ W}$$

$$\mathcal{P}_2 = I^2 R_2 = (0.33 \text{ A})^2 (10 \Omega) = 1.1 \text{ W}$$

Hence, the total power delivered to the resistors is $\mathcal{P}_1 + \mathcal{P}_2 = 2.0 \text{ W}$.

The 12-V battery delivers power $I\mathcal{E}_2 = 4.0 \text{ W}$. Half of this power is delivered to the two resistors, as we just calculated. The other half is delivered to the 6-V battery, which is being charged by the 12-V battery. If we had included the internal resistances of the batteries in our analysis, some of the power would appear as internal energy in the batteries; as a result, we would have found that less power was being delivered to the 6-V battery.

EXAMPLE 28.8 Applying Kirchhoff's Rules

Find the currents I_1 , I_2 , and I_3 in the circuit shown in Figure 28.14.

Solution Notice that we cannot reduce this circuit to a simpler form by means of the rules of adding resistances in series and in parallel. We must use Kirchhoff's rules to analyze this circuit. We arbitrarily choose the directions of the currents as labeled in Figure 28.14. Applying Kirchhoff's junction rule to junction c gives

$$(1) \quad I_1 + I_2 = I_3$$

We now have one equation with three unknowns— I_1 , I_2 , and I_3 . There are three loops in the circuit— $abcd$, $befcb$, and $aefta$. We therefore need only two loop equations to determine the unknown currents. (The third loop equation would give no new information.) Applying Kirchhoff's loop rule to loops $abcd$ and $befcb$ and traversing these loops clockwise, we obtain the expressions

$$(2) \quad abcd \quad 10 \text{ V} - (6 \Omega)I_1 - (2 \Omega)I_3 = 0$$

$$(3) \quad befcb \quad -14 \text{ V} + (6 \Omega)I_1 - 10 \text{ V} - (4 \Omega)I_2 = 0$$

Note that in loop *befcb* we obtain a positive value when traversing the $6\text{-}\Omega$ resistor because our direction of travel is opposite the assumed direction of I_1 .

Expressions (1), (2), and (3) represent three independent equations with three unknowns. Substituting Equation (1) into Equation (2) gives

$$10\text{ V} - (6\ \Omega)I_1 - (2\ \Omega)(I_1 + I_2) = 0$$

$$(4) \quad 10\text{ V} = (8\ \Omega)I_1 + (2\ \Omega)I_2$$

Dividing each term in Equation (3) by 2 and rearranging gives

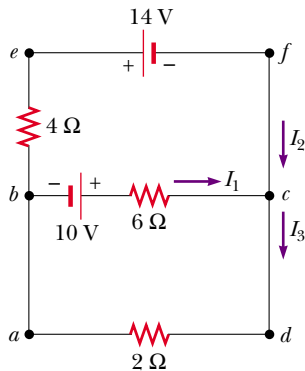

Figure 28.14 A circuit containing three loops.

$$(5) \quad -12\text{ V} = -(3\ \Omega)I_1 + (2\ \Omega)I_2$$

Subtracting Equation (5) from Equation (4) eliminates I_2 , giving

$$22\text{ V} = (11\ \Omega)I_1$$

$$I_1 = 2\text{ A}$$

Using this value of I_1 in Equation (5) gives a value for I_2 :

$$(2\ \Omega)I_2 = (3\ \Omega)I_1 - 12\text{ V} = (3\ \Omega)(2\text{ A}) - 12\text{ V} = -6\text{ V}$$

$$I_2 = -3\text{ A}$$

Finally,

$$I_3 = I_1 + I_2 = -1\text{ A}$$

The fact that I_2 and I_3 are both negative indicates only that the currents are opposite the direction we chose for them. However, the numerical values are correct. What would have happened had we left the current directions as labeled in Figure 28.14 but traversed the loops in the opposite direction?

Exercise Find the potential difference between points *b* and *c*.

Answer 2 V.

EXAMPLE 28.9 A Multiloop Circuit

(a) Under steady-state conditions, find the unknown currents I_1 , I_2 , and I_3 in the multiloop circuit shown in Figure 28.15.

Solution First note that because the capacitor represents an open circuit, there is no current between *g* and *b* along path *ghab* under steady-state conditions. Therefore, when the charges associated with I_1 reach point *g*, they all go through the 8.00-V battery to point *b*; hence, $I_{gb} = I_1$. Labeling the currents as shown in Figure 28.15 and applying Equation 28.9 to junction *c*, we obtain

$$(1) \quad I_1 + I_2 = I_3$$

Equation 28.10 applied to loops *defcd* and *cfgbc*, traversed clockwise, gives

$$(2) \quad \text{defcd} \quad 4.00\text{ V} - (3.00\ \Omega)I_2 - (5.00\ \Omega)I_3 = 0$$

$$(3) \quad \text{cfgbc} \quad (3.00\ \Omega)I_2 - (5.00\ \Omega)I_1 + 8.00\text{ V} = 0$$

From Equation (1) we see that $I_1 = I_3 - I_2$, which, when substituted into Equation (3), gives

$$(4) \quad (8.00\ \Omega)I_2 - (5.00\ \Omega)I_3 + 8.00\text{ V} = 0$$

Subtracting Equation (4) from Equation (2), we eliminate I_3 and find that

$$I_2 = -\frac{4.00\text{ V}}{11.0\ \Omega} = -0.364\text{ A}$$

Because our value for I_2 is negative, we conclude that the direction of I_2 is from *c* to *f* through the $3.00\text{-}\Omega$ resistor. Despite

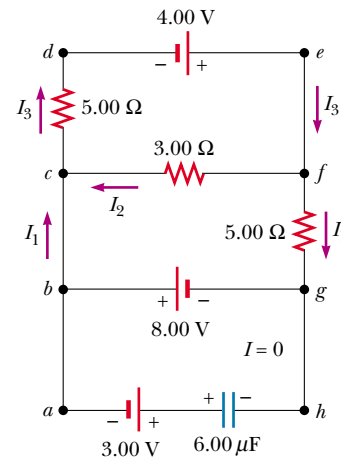

Figure 28.15 A multiloop circuit. Kirchhoff's loop rule can be applied to any closed loop, including the one containing the capacitor.

this interpretation of the direction, however, we must continue to use this negative value for I_2 in subsequent calculations because our equations were established with our original choice of direction.

Using $I_2 = -0.364$ A in Equations (3) and (1) gives

$$I_1 = 1.38 \text{ A} \quad I_3 = 1.02 \text{ A}$$

(b) What is the charge on the capacitor?

Solution We can apply Kirchhoff's loop rule to loop *bghab* (or any other loop that contains the capacitor) to find the potential difference ΔV_{cap} across the capacitor. We enter this potential difference in the equation without reference to a sign convention because the charge on the capacitor depends only on the magnitude of the potential difference. Moving clockwise around this loop, we obtain

$$\begin{aligned} -8.00 \text{ V} + \Delta V_{\text{cap}} - 3.00 \text{ V} &= 0 \\ \Delta V_{\text{cap}} &= 11.0 \text{ V} \end{aligned}$$

Because $Q = C \Delta V_{\text{cap}}$ (see Eq. 26.1), the charge on the capacitor is

$$Q = (6.00 \mu\text{F})(11.0 \text{ V}) = 66.0 \mu\text{C}$$

Why is the left side of the capacitor positively charged?

Exercise Find the voltage across the capacitor by traversing any other loop.

Answer 11.0 V.

Exercise Reverse the direction of the 3.00-V battery and answer parts (a) and (b) again.

Answer (a) $I_1 = 1.38$ A, $I_2 = -0.364$ A, $I_3 = 1.02$ A; (b) 30 μC .

28.4 RC CIRCUITS

So far we have been analyzing steady-state circuits, in which the current is constant. In circuits containing capacitors, the current may vary in time. A circuit containing a series combination of a resistor and a capacitor is called an **RC circuit**.

Charging a Capacitor

Let us assume that the capacitor in Figure 28.16 is initially uncharged. There is no current while switch S is open (Fig. 28.16b). If the switch is closed at $t = 0$, however, charge begins to flow, setting up a current in the circuit, and the capacitor begins to charge.⁴ Note that during charging, charges do not jump across the capacitor plates because the gap between the plates represents an open circuit. Instead, charge is transferred between each plate and its connecting wire due to the electric field established in the wires by the battery, until the capacitor is fully charged. As the plates become charged, the potential difference across the capacitor increases. The value of the maximum charge depends on the voltage of the battery. Once the maximum charge is reached, the current in the circuit is zero because the potential difference across the capacitor matches that supplied by the battery.

To analyze this circuit quantitatively, let us apply Kirchhoff's loop rule to the circuit after the switch is closed. Traversing the loop clockwise gives

$$\mathcal{E} - \frac{q}{C} - IR = 0 \quad (28.11)$$

where q/C is the potential difference across the capacitor and IR is the potential

⁴ In previous discussions of capacitors, we assumed a steady-state situation, in which no current was present in any branch of the circuit containing a capacitor. Now we are considering the case *before* the steady-state condition is realized; in this situation, charges are moving and a current exists in the wires connected to the capacitor.

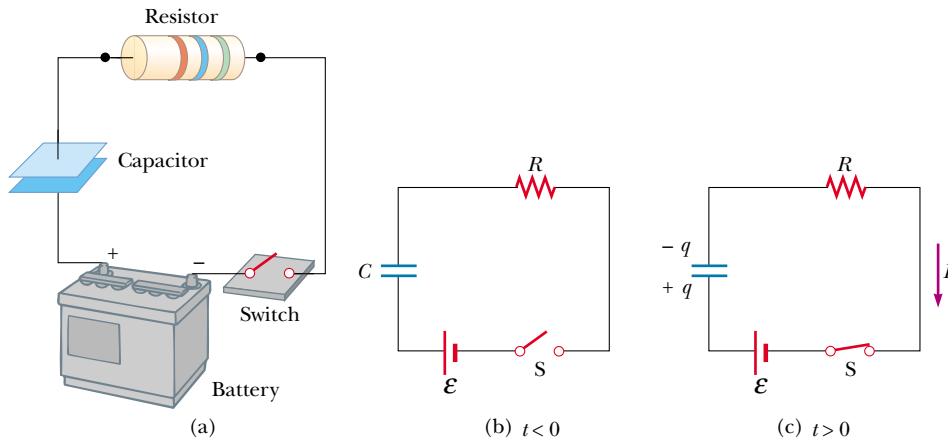

Figure 28.16 (a) A capacitor in series with a resistor, switch, and battery. (b) Circuit diagram representing this system at time $t < 0$, before the switch is closed. (c) Circuit diagram at time $t > 0$, after the switch has been closed.

difference across the resistor. We have used the sign conventions discussed earlier for the signs on \mathcal{E} and IR . For the capacitor, notice that we are traveling in the direction from the positive plate to the negative plate; this represents a decrease in potential. Thus, we use a negative sign for this voltage in Equation 28.11. Note that q and I are *instantaneous* values that depend on time (as opposed to steady-state values) as the capacitor is being charged.

We can use Equation 28.11 to find the initial current in the circuit and the maximum charge on the capacitor. At the instant the switch is closed ($t = 0$), the charge on the capacitor is zero, and from Equation 28.11 we find that the initial current in the circuit I_0 is a maximum and is equal to

$$I_0 = \frac{\mathcal{E}}{R} \quad (\text{current at } t = 0) \quad (28.12)$$

Maximum current

At this time, the potential difference from the battery terminals appears entirely across the resistor. Later, when the capacitor is charged to its maximum value Q , charges cease to flow, the current in the circuit is zero, and the potential difference from the battery terminals appears entirely across the capacitor. Substituting $I = 0$ into Equation 28.11 gives the charge on the capacitor at this time:

$$Q = C\mathcal{E} \quad (\text{maximum charge}) \quad (28.13)$$

Maximum charge on the capacitor

To determine analytical expressions for the time dependence of the charge and current, we must solve Equation 28.11—a single equation containing two variables, q and I . The current in all parts of the series circuit must be the same. Thus, the current in the resistance R must be the same as the current flowing out of and into the capacitor plates. This current is equal to the time rate of change of the charge on the capacitor plates. Thus, we substitute $I = dq/dt$ into Equation 28.11 and rearrange the equation:

$$\frac{dq}{dt} = \frac{\mathcal{E}}{R} - \frac{q}{RC}$$

To find an expression for q , we first combine the terms on the right-hand side:

$$\frac{dq}{dt} = \frac{C\mathcal{E}}{RC} - \frac{q}{RC} = -\frac{q - C\mathcal{E}}{RC}$$

Now we multiply by dt and divide by $q - C\mathcal{E}$ to obtain

$$\frac{dq}{q - C\mathcal{E}} = -\frac{1}{RC} dt$$

Integrating this expression, using the fact that $q = 0$ at $t = 0$, we obtain

$$\int_0^q \frac{dq}{q - C\mathcal{E}} = -\frac{1}{RC} \int_0^t dt$$

$$\ln\left(\frac{q - C\mathcal{E}}{-C\mathcal{E}}\right) = -\frac{t}{RC}$$

From the definition of the natural logarithm, we can write this expression as

Charge versus time for a capacitor being charged

$$q(t) = C\mathcal{E} (1 - e^{-t/RC}) = Q(1 - e^{-t/RC}) \quad (28.14)$$

where e is the base of the natural logarithm and we have made the substitution $C\mathcal{E} = Q$ from Equation 28.13.

We can find an expression for the charging current by differentiating Equation 28.14 with respect to time. Using $I = dq/dt$, we find that

Current versus time for a charging capacitor

$$I(t) = \frac{\mathcal{E}}{R} e^{-t/RC} \quad (28.15)$$

Plots of capacitor charge and circuit current versus time are shown in Figure 28.17. Note that the charge is zero at $t = 0$ and approaches the maximum value $C\mathcal{E}$ as $t \rightarrow \infty$. The current has its maximum value $I_0 = \mathcal{E}/R$ at $t = 0$ and decays exponentially to zero as $t \rightarrow \infty$. The quantity RC , which appears in the exponents of Equations 28.14 and 28.15, is called the **time constant** τ of the circuit. It represents the time it takes the current to decrease to $1/e$ of its initial value; that is, in a time τ , $I = e^{-1}I_0 = 0.368I_0$. In a time 2τ , $I = e^{-2}I_0 = 0.135I_0$, and so forth. Likewise, in a time τ , the charge increases from zero to $C\mathcal{E} (1 - e^{-1}) = 0.632C\mathcal{E}$.

The following dimensional analysis shows that τ has the units of time:

$$[\tau] = [RC] = \left[\frac{\Delta V}{I} \times \frac{Q}{\Delta V} \right] = \left[\frac{Q}{Q/\Delta t} \right] = [\Delta t] = \text{T}$$

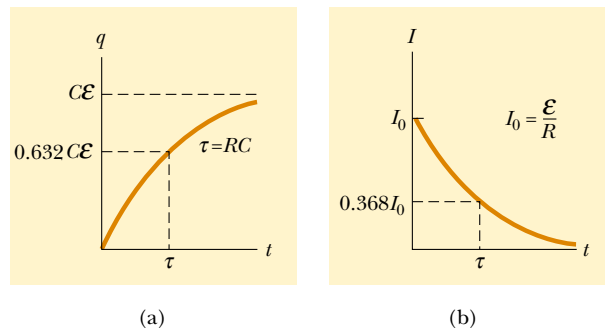

Figure 28.17 (a) Plot of capacitor charge versus time for the circuit shown in Figure 28.16. After a time interval equal to one time constant τ has passed, the charge is 63.2% of the maximum value $C\mathcal{E}$. The charge approaches its maximum value as t approaches infinity. (b) Plot of current versus time for the circuit shown in Figure 28.16. The current has its maximum value $I_0 = \mathcal{E}/R$ at $t = 0$ and decays to zero exponentially as t approaches infinity. After a time interval equal to one time constant τ has passed, the current is 36.8% of its initial value.

Because $\tau = RC$ has units of time, the combination t/RC is dimensionless, as it must be in order to be an exponent of e in Equations 28.14 and 28.15.

The energy output of the battery as the capacitor is fully charged is $Q\mathcal{E} = C\mathcal{E}^2$. After the capacitor is fully charged, the energy stored in the capacitor is $\frac{1}{2}Q\mathcal{E} = \frac{1}{2}C\mathcal{E}^2$, which is just half the energy output of the battery. It is left as a problem (Problem 60) to show that the remaining half of the energy supplied by the battery appears as internal energy in the resistor.

Discharging a Capacitor

Now let us consider the circuit shown in Figure 28.18, which consists of a capacitor carrying an initial charge Q , a resistor, and a switch. The *initial* charge Q is not the same as the *maximum* charge Q in the previous discussion, unless the discharge occurs after the capacitor is fully charged (as described earlier). When the switch is open, a potential difference Q/C exists across the capacitor and there is zero potential difference across the resistor because $I = 0$. If the switch is closed at $t = 0$, the capacitor begins to discharge through the resistor. At some time t during the discharge, the current in the circuit is I and the charge on the capacitor is q (Fig. 28.18b). The circuit in Figure 28.18 is the same as the circuit in Figure 28.16 except for the absence of the battery. Thus, we eliminate the emf \mathcal{E} from Equation 28.11 to obtain the appropriate loop equation for the circuit in Figure 28.18:

$$-\frac{q}{C} - IR = 0 \quad (28.16)$$

When we substitute $I = dq/dt$ into this expression, it becomes

$$\begin{aligned} -R \frac{dq}{dt} &= \frac{q}{C} \\ \frac{dq}{q} &= -\frac{1}{RC} dt \end{aligned}$$

Integrating this expression, using the fact that $q = Q$ at $t = 0$, gives

$$\begin{aligned} \int_Q^q \frac{dq}{q} &= -\frac{1}{RC} \int_0^t dt \\ \ln\left(\frac{q}{Q}\right) &= -\frac{t}{RC} \end{aligned}$$

$$q(t) = Qe^{-t/RC} \quad (28.17)$$

Differentiating this expression with respect to time gives the instantaneous current as a function of time:

$$I(t) = \frac{dq}{dt} = \frac{d}{dt} (Qe^{-t/RC}) = -\frac{Q}{RC} e^{-t/RC} \quad (28.18)$$

where $Q/RC = I_0$ is the initial current. The negative sign indicates that the current direction now that the capacitor is discharging is opposite the current direction when the capacitor was being charged. (Compare the current directions in Figs. 28.16c and 28.18b.) We see that both the charge on the capacitor and the current decay exponentially at a rate characterized by the time constant $\tau = RC$.

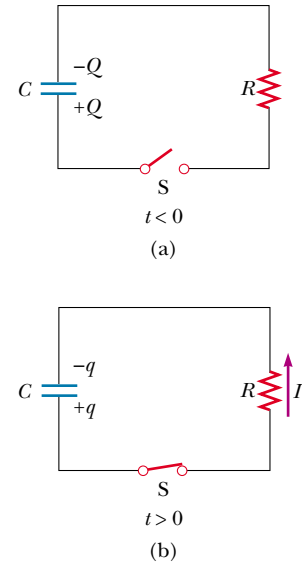

Figure 28.18 (a) A charged capacitor connected to a resistor and a switch, which is open at $t < 0$. (b) After the switch is closed, a current that decreases in magnitude with time is set up in the direction shown, and the charge on the capacitor decreases exponentially with time.

Charge versus time for a discharging capacitor

Current versus time for a discharging capacitor

CONCEPTUAL EXAMPLE 28.10 Intermittent Windshield Wipers

Many automobiles are equipped with windshield wipers that can operate intermittently during a light rainfall. How does the operation of such wipers depend on the charging and discharging of a capacitor?

Solution The wipers are part of an RC circuit whose time constant can be varied by selecting different values of R

through a multiposition switch. As it increases with time, the voltage across the capacitor reaches a point at which it triggers the wipers and discharges, ready to begin another charging cycle. The time interval between the individual sweeps of the wipers is determined by the value of the time constant.

EXAMPLE 28.11 Charging a Capacitor in an RC Circuit

An uncharged capacitor and a resistor are connected in series to a battery, as shown in Figure 28.19. If $\mathcal{E} = 12.0 \text{ V}$, $C = 5.00 \mu\text{F}$, and $R = 8.00 \times 10^5 \Omega$, find the time constant of the circuit, the maximum charge on the capacitor, the maximum current in the circuit, and the charge and current as functions of time.

Solution The time constant of the circuit is $\tau = RC = (8.00 \times 10^5 \Omega)(5.00 \times 10^{-6} \text{ F}) = 4.00 \text{ s}$. The maximum charge on the capacitor is $Q = C\mathcal{E} = (5.00 \mu\text{F})(12.0 \text{ V}) = 60.0 \mu\text{C}$. The maximum current in the circuit is $I_0 = \mathcal{E}/R = (12.0 \text{ V})/(8.00 \times 10^5 \Omega) = 15.0 \mu\text{A}$. Using these values and Equations 28.14 and 28.15, we find that

$$q(t) = (60.0 \mu\text{C})(1 - e^{-t/4.00 \text{ s}})$$

$$I(t) = (15.0 \mu\text{A})e^{-t/4.00 \text{ s}}$$

Graphs of these functions are provided in Figure 28.20.

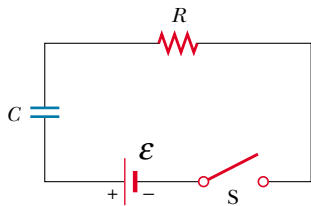

Figure 28.19 The switch of this series RC circuit, open for times $t < 0$, is closed at $t = 0$.

Exercise Calculate the charge on the capacitor and the current in the circuit after one time constant has elapsed.

Answer $37.9 \mu\text{C}$, $5.52 \mu\text{A}$.

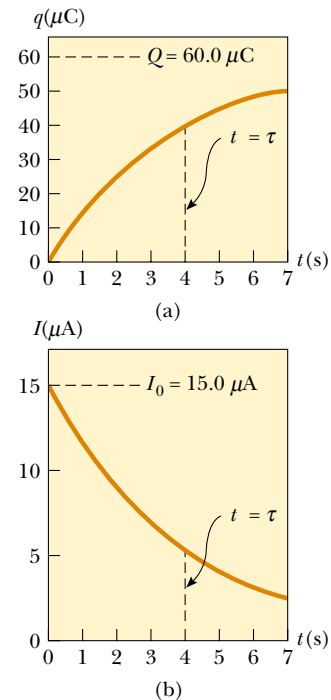

Figure 28.20 Plots of (a) charge versus time and (b) current versus time for the RC circuit shown in Figure 28.19, with $\mathcal{E} = 12.0 \text{ V}$, $R = 8.00 \times 10^5 \Omega$, and $C = 5.00 \mu\text{F}$.

EXAMPLE 28.12 Discharging a Capacitor in an RC Circuit

Consider a capacitor of capacitance C that is being discharged through a resistor of resistance R , as shown in Figure 28.18. (a) After how many time constants is the charge on the capacitor one-fourth its initial value?

Solution The charge on the capacitor varies with time according to Equation 28.17, $q(t) = Qe^{-t/RC}$. To find the time it takes q to drop to one-fourth its initial value, we substitute $q(t) = Q/4$ into this expression and solve for t :

$$\frac{Q}{4} = Qe^{-t/RC}$$

$$\frac{1}{4} = e^{-t/RC}$$

Taking logarithms of both sides, we find

$$-\ln 4 = -\frac{t}{RC}$$

$$t = RC(\ln 4) = 1.39RC = 1.39\tau$$

(b) The energy stored in the capacitor decreases with time as the capacitor discharges. After how many time constants is this stored energy one-fourth its initial value?

Solution Using Equations 26.11 ($U = Q^2/2C$) and 28.17, we can express the energy stored in the capacitor at any time t as

$$U = \frac{q^2}{2C} = \frac{(Qe^{-t/RC})^2}{2C} = \frac{Q^2}{2C} e^{-2t/RC} = U_0 e^{-2t/RC}$$

where $U_0 = Q^2/2C$ is the initial energy stored in the capacitor. As in part (a), we now set $U = U_0/4$ and solve for t :

$$\frac{U_0}{4} = U_0 e^{-2t/RC}$$

$$\frac{1}{4} = e^{-2t/RC}$$

Again, taking logarithms of both sides and solving for t gives

$$t = \frac{1}{2}RC(\ln 4) = 0.693RC = 0.693\tau$$

Exercise After how many time constants is the current in the circuit one-half its initial value?

Answer $0.693RC = 0.693\tau$.

EXAMPLE 28.13 Energy Delivered to a Resistor

A 5.00- μF capacitor is charged to a potential difference of 800 V and then discharged through a 25.0-k Ω resistor. How much energy is delivered to the resistor in the time it takes to fully discharge the capacitor?

Solution We shall solve this problem in two ways. The first way is to note that the initial energy in the circuit equals the energy stored in the capacitor, $C\mathcal{E}^2/2$ (see Eq. 26.11). Once the capacitor is fully discharged, the energy stored in it is zero. Because energy is conserved, the initial energy stored in the capacitor is transformed into internal energy in the resistor. Using the given values of C and \mathcal{E} , we find

$$\text{Energy} = \frac{1}{2}C\mathcal{E}^2 = \frac{1}{2}(5.00 \times 10^{-6} \text{ F})(800 \text{ V})^2 = 1.60 \text{ J}$$

The second way, which is more difficult but perhaps more instructive, is to note that as the capacitor discharges through the resistor, the rate at which energy is delivered to the resistor is given by I^2R , where I is the instantaneous current given by Equation 28.18. Because power is defined as the time rate of change of energy, we conclude that the energy delivered to the resistor must equal the time integral of $I^2R dt$:

$$\text{Energy} = \int_0^\infty I^2 R dt = \int_0^\infty (I_0 e^{-t/RC})^2 R dt$$

To evaluate this integral, we note that the initial current I_0 is equal to \mathcal{E}/R and that all parameters except t are constant. Thus, we find

$$(1) \quad \text{Energy} = \frac{\mathcal{E}^2}{R} \int_0^\infty e^{-2t/RC} dt$$

This integral has a value of $RC/2$; hence, we find

$$\text{Energy} = \frac{1}{2}C\mathcal{E}^2$$

which agrees with the result we obtained using the simpler approach, as it must. Note that we can use this second approach to find the total energy delivered to the resistor at any time after the switch is closed by simply replacing the upper limit in the integral with that specific value of t .

Exercise Show that the integral in Equation (1) has the value $RC/2$.

Optional Section

28.5 ELECTRICAL INSTRUMENTS

The Ammeter

A device that measures current is called an **ammeter**. The current to be measured must pass directly through the ammeter, so the ammeter must be connected in se-

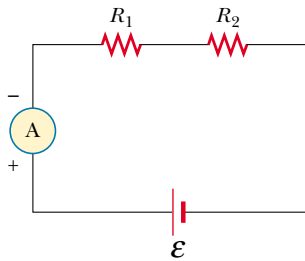

Figure 28.21 Current can be measured with an ammeter connected in series with the resistor and battery of a circuit. An ideal ammeter has zero resistance.

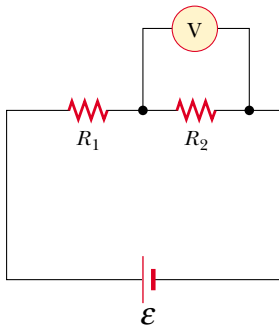

Figure 28.22 The potential difference across a resistor can be measured with a voltmeter connected in parallel with the resistor. An ideal voltmeter has infinite resistance.

ries with other elements in the circuit, as shown in Figure 28.21. When using an ammeter to measure direct currents, you must be sure to connect it so that current enters the instrument at the positive terminal and exits at the negative terminal.

Ideally, an ammeter should have zero resistance so that the current being measured is not altered. In the circuit shown in Figure 28.21, this condition requires that the resistance of the ammeter be much less than $R_1 + R_2$. Because any ammeter always has some internal resistance, the presence of the ammeter in the circuit slightly reduces the current from the value it would have in the meter's absence.

The Voltmeter

A device that measures potential difference is called a **voltmeter**. The potential difference between any two points in a circuit can be measured by attaching the terminals of the voltmeter between these points without breaking the circuit, as shown in Figure 28.22. The potential difference across resistor R_2 is measured by connecting the voltmeter in parallel with R_2 . Again, it is necessary to observe the polarity of the instrument. The positive terminal of the voltmeter must be connected to the end of the resistor that is at the higher potential, and the negative terminal to the end of the resistor at the lower potential.

An ideal voltmeter has infinite resistance so that no current passes through it. In Figure 28.22, this condition requires that the voltmeter have a resistance much greater than R_2 . In practice, if this condition is not met, corrections should be made for the known resistance of the voltmeter.

The Galvanometer

The **galvanometer** is the main component in analog ammeters and voltmeters. Figure 28.23a illustrates the essential features of a common type called the *D'Arsonval galvanometer*. It consists of a coil of wire mounted so that it is free to rotate on a pivot in a magnetic field provided by a permanent magnet. The basic op-

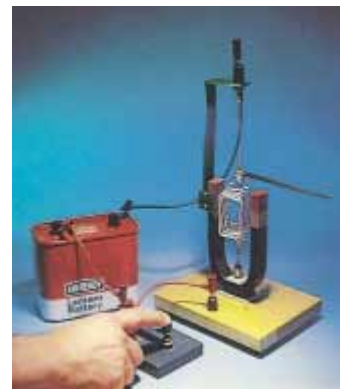
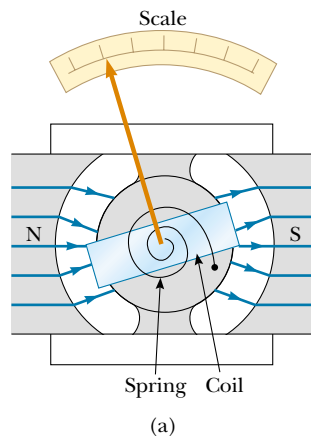

Figure 28.23 (a) The principal components of a D'Arsonval galvanometer. When the coil situated in a magnetic field carries a current, the magnetic torque causes the coil to twist. The angle through which the coil rotates is proportional to the current in the coil because of the counteracting torque of the spring. (b) A large-scale model of a galvanometer movement. Why does the coil rotate about the vertical axis after the switch is closed?

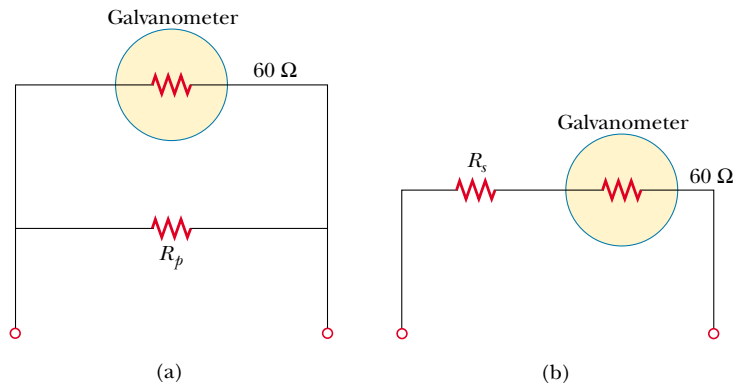

Figure 28.24 (a) When a galvanometer is to be used as an ammeter, a shunt resistor R_p is connected in parallel with the galvanometer. (b) When the galvanometer is used as a voltmeter, a resistor R_s is connected in series with the galvanometer.

eration of the galvanometer makes use of the fact that a torque acts on a current loop in the presence of a magnetic field (Chapter 29). The torque experienced by the coil is proportional to the current through it: the larger the current, the greater the torque and the more the coil rotates before the spring tightens enough to stop the rotation. Hence, the deflection of a needle attached to the coil is proportional to the current. Once the instrument is properly calibrated, it can be used in conjunction with other circuit elements to measure either currents or potential differences.

A typical off-the-shelf galvanometer is often not suitable for use as an ammeter, primarily because it has a resistance of about $60\ \Omega$. An ammeter resistance this great considerably alters the current in a circuit. You can understand this by considering the following example: The current in a simple series circuit containing a 3-V battery and a $3\text{-}\Omega$ resistor is 1 A. If you insert a $60\text{-}\Omega$ galvanometer in this circuit to measure the current, the total resistance becomes $63\ \Omega$ and the current is reduced to 0.048 A!

A second factor that limits the use of a galvanometer as an ammeter is the fact that a typical galvanometer gives a full-scale deflection for currents of the order of 1 mA or less. Consequently, such a galvanometer cannot be used directly to measure currents greater than this value. However, it can be converted to a useful ammeter by placing a shunt resistor R_p in parallel with the galvanometer, as shown in Figure 28.24a. The value of R_p must be much less than the galvanometer resistance so that most of the current to be measured passes through the shunt resistor.

A galvanometer can also be used as a voltmeter by adding an external resistor R_s in series with it, as shown in Figure 28.24b. In this case, the external resistor must have a value much greater than the resistance of the galvanometer to ensure that the galvanometer does not significantly alter the voltage being measured.

The Wheatstone Bridge

An unknown resistance value can be accurately measured using a circuit known as a **Wheatstone bridge** (Fig. 28.25). This circuit consists of the unknown resistance R_x , three known resistances R_1 , R_2 , and R_3 (where R_1 is a calibrated variable resistor), a galvanometer, and a battery. The known resistor R_1 is varied until the galvanometer reading is zero—that is, until there is no current from a to b . Under this condition the bridge is said to be balanced. Because the electric potential at

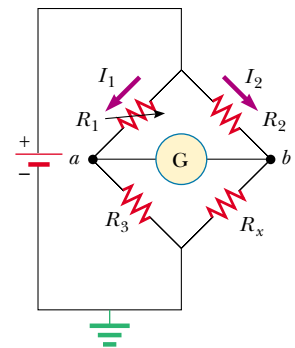
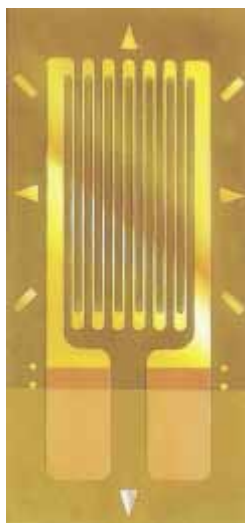

Figure 28.25 Circuit diagram for a Wheatstone bridge, an instrument used to measure an unknown resistance R_x in terms of known resistances R_1 , R_2 , and R_3 . When the bridge is balanced, no current is present in the galvanometer. The arrow superimposed on the circuit symbol for resistor R_1 indicates that the value of this resistor can be varied by the person operating the bridge.



The strain gauge, a device used for experimental stress analysis, consists of a thin coiled wire bonded to a flexible plastic backing. The gauge measures stresses by detecting changes in the resistance of the coil as the strip bends. Resistance measurements are made with this device as one element of a Wheatstone bridge. Strain gauges are commonly used in modern electronic balances to measure the masses of objects.



Figure 28.26 Voltages, currents, and resistances are frequently measured with digital multimeters like this one.

point a must equal the potential at point b when the bridge is balanced, the potential difference across R_1 must equal the potential difference across R_2 . Likewise, the potential difference across R_3 must equal the potential difference across R_x . From these considerations we see that

$$(1) \quad I_1 R_1 = I_2 R_2$$

$$(2) \quad I_1 R_3 = I_2 R_x$$

Dividing Equation (1) by Equation (2) eliminates the currents, and solving for R_x , we find that

$$R_x = \frac{R_2 R_3}{R_1} \quad (28.19)$$

A number of similar devices also operate on the principle of null measurement (that is, adjustment of one circuit element to make the galvanometer read zero). One example is the capacitance bridge used to measure unknown capacitances. These devices do not require calibrated meters and can be used with any voltage source.

Wheatstone bridges are not useful for resistances above $10^5 \Omega$, but modern electronic instruments can measure resistances as high as $10^{12} \Omega$. Such instruments have an extremely high resistance between their input terminals. For example, input resistances of $10^{10} \Omega$ are common in most digital multimeters, which are devices that are used to measure voltage, current, and resistance (Fig. 28.26).

The Potentiometer

A **potentiometer** is a circuit that is used to measure an unknown emf \mathcal{E}_x by comparison with a known emf. In Figure 28.27, point d represents a sliding contact that is used to vary the resistance (and hence the potential difference) between points a and d . The other required components are a galvanometer, a battery of known emf \mathcal{E}_0 , and a battery of unknown emf \mathcal{E}_x .

With the currents in the directions shown in Figure 28.27, we see from Kirchhoff's junction rule that the current in the resistor R_x is $I - I_x$, where I is the current in the left branch (through the battery of emf \mathcal{E}_0) and I_x is the current in the right branch. Kirchhoff's loop rule applied to loop $abcd$ traversed clockwise gives

$$-\mathcal{E}_x + (I - I_x)R_x = 0$$

Because current I_x passes through it, the galvanometer displays a nonzero reading. The sliding contact at d is now adjusted until the galvanometer reads zero (indicating a balanced circuit and that the potentiometer is another null-measurement device). Under this condition, the current in the galvanometer is zero, and the potential difference between a and d must equal the unknown emf \mathcal{E}_x :

$$\mathcal{E}_x = IR_x$$

Next, the battery of unknown emf is replaced by a standard battery of known emf \mathcal{E}_s , and the procedure is repeated. If R_s is the resistance between a and d when balance is achieved this time, then

$$\mathcal{E}_s = IR_s$$

where it is assumed that I remains the same. Combining this expression with the preceding one, we see that

$$\mathcal{E}_x = \frac{R_x}{R_s} \mathcal{E}_s \quad (28.20)$$

If the resistor is a wire of resistivity ρ , its resistance can be varied by using the sliding contact to vary the length L , indicating how much of the wire is part of the circuit. With the substitutions $R_s = \rho L_s/A$ and $R_x = \rho L_x/A$, Equation 28.20 becomes

$$\mathcal{E}_x = \frac{L_x}{L_s} \mathcal{E}_s \quad (28.21)$$

where L_x is the resistor length when the battery of unknown emf \mathcal{E}_x is in the circuit and L_s is the resistor length when the standard battery is in the circuit.

The sliding-wire circuit of Figure 28.27 without the unknown emf and the galvanometer is sometimes called a *voltage divider*. This circuit makes it possible to tap into any desired smaller portion of the emf \mathcal{E}_0 by adjusting the length of the resistor.

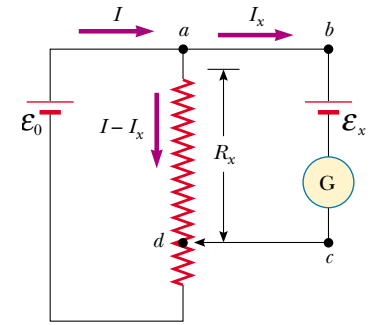

Figure 28.27 Circuit diagram for a potentiometer. The circuit is used to measure an unknown emf \mathcal{E}_x .

Optional Section

28.6 HOUSEHOLD WIRING AND ELECTRICAL SAFETY

Household circuits represent a practical application of some of the ideas presented in this chapter. In our world of electrical appliances, it is useful to understand the power requirements and limitations of conventional electrical systems and the safety measures that prevent accidents.

In a conventional installation, the utility company distributes electric power to individual homes by means of a pair of wires, with each home connected in parallel to these wires. One wire is called the *live wire*,⁵ as illustrated in Figure 28.28, and the other is called the *neutral wire*. The potential difference between these two wires is about 120 V. This voltage alternates in time, with the neutral wire connected to ground and the potential of the live wire oscillating relative to ground. Much of what we have learned so far for the constant-emf situation (direct current) can also be applied to the alternating current that power companies supply to businesses and households. (Alternating voltage and current are discussed in Chapter 33.)

A meter is connected in series with the live wire entering the house to record the household's usage of electricity. After the meter, the wire splits so that there are several separate circuits in parallel distributed throughout the house. Each circuit contains a circuit breaker (or, in older installations, a fuse). The wire and circuit breaker for each circuit are carefully selected to meet the current demands for that circuit. If a circuit is to carry currents as large as 30 A, a heavy wire and an appropriate circuit breaker must be selected to handle this current. A circuit used to power only lamps and small appliances often requires only 15 A. Each circuit has its own circuit breaker to accommodate various load conditions.



As an example, consider a circuit in which a toaster oven, a microwave oven, and a coffee maker are connected (corresponding to R_1 , R_2 , and R_3 in Figure 28.28 and as shown in the chapter-opening photograph). We can calculate the current drawn by each appliance by using the expression $\mathcal{P} = I\Delta V$. The toaster oven, rated at 1 000 W, draws a current of $1\,000\text{ W}/120\text{ V} = 8.33\text{ A}$. The microwave oven, rated at 1 300 W, draws 10.8 A, and the coffee maker, rated at 800 W, draws 6.67 A. If the three appliances are operated simultaneously, they draw a total cur-

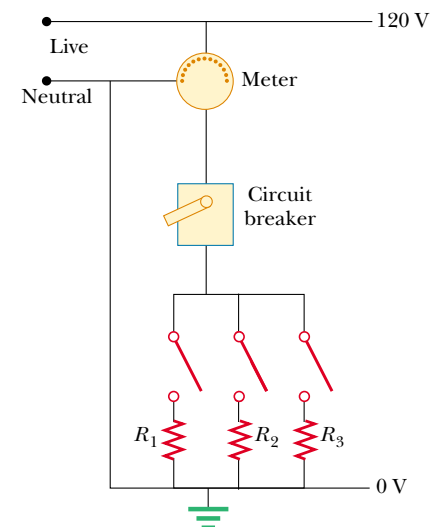

Figure 28.28 Wiring diagram for a household circuit. The resistances represent appliances or other electrical devices that operate with an applied voltage of 120 V.

⁵ *Live wire* is a common expression for a conductor whose electric potential is above or below ground potential.



Figure 28.29 A power connection for a 240-V appliance.

rent of 25.8 A. Therefore, the circuit should be wired to handle at least this much current. If the rating of the circuit breaker protecting the circuit is too small—say, 20 A—the breaker will be tripped when the third appliance is turned on, preventing all three appliances from operating. To avoid this situation, the toaster oven and coffee maker can be operated on one 20-A circuit and the microwave oven on a separate 20-A circuit.

Many heavy-duty appliances, such as electric ranges and clothes dryers, require 240 V for their operation (Fig. 28.29). The power company supplies this voltage by providing a third wire that is 120 V below ground potential. The potential difference between this live wire and the other live wire (which is 120 V above ground potential) is 240 V. An appliance that operates from a 240-V line requires half the current of one operating from a 120-V line; therefore, smaller wires can be used in the higher-voltage circuit without overheating.

Electrical Safety

When the live wire of an electrical outlet is connected directly to ground, the circuit is completed and a short-circuit condition exists. A *short circuit* occurs when almost zero resistance exists between two points at different potentials; this results in a very large current. When this happens accidentally, a properly operating circuit breaker opens the circuit and no damage is done. However, a person in contact with ground can be electrocuted by touching the live wire of a frayed cord or other exposed conductor. An exceptionally good (although very dangerous) ground contact is made when the person either touches a water pipe (normally at ground potential) or stands on the ground with wet feet. The latter situation represents a good ground because normal, nondistilled water is a conductor because it contains a large number of ions associated with impurities. This situation should be avoided at all cost.

Electric shock can result in fatal burns, or it can cause the muscles of vital organs, such as the heart, to malfunction. The degree of damage to the body depends on the magnitude of the current, the length of time it acts, the part of the body touched by the live wire, and the part of the body through which the current passes. Currents of 5 mA or less cause a sensation of shock but ordinarily do little or no damage. If the current is larger than about 10 mA, the muscles contract and the person may be unable to release the live wire. If a current of about 100 mA passes through the body for only a few seconds, the result can be fatal. Such a large current paralyzes the respiratory muscles and prevents breathing. In some cases, currents of about 1 A through the body can produce serious (and sometimes fatal) burns. In practice, no contact with live wires is regarded as safe whenever the voltage is greater than 24 V.

Many 120-V outlets are designed to accept a three-pronged power cord such as the one shown in Figure 28.30. (This feature is required in all new electrical installations.) One of these prongs is the live wire at a nominal potential of 120 V. The second, called the “neutral,” is nominally at 0 V and carries current to ground. The third, round prong is a safety ground wire that normally carries no current but is both grounded and connected directly to the casing of the appliance. If the live wire is accidentally shorted to the casing (which can occur if the wire insulation wears off), most of the current takes the low-resistance path through the appliance to ground. In contrast, if the casing of the appliance is not properly grounded and a short occurs, anyone in contact with the appliance experiences an electric shock because the body provides a low-resistance path to ground.



Figure 28.30 A three-pronged power cord for a 120-V appliance.

Special power outlets called *ground-fault interrupters* (GFIs) are now being used in kitchens, bathrooms, basements, exterior outlets, and other hazardous areas of new homes. These devices are designed to protect persons from electric shock by sensing small currents (≈ 5 mA) leaking to ground. (The principle of their operation is described in Chapter 31.) When an excessive leakage current is detected, the current is shut off in less than 1 ms.

Quick Quiz 28.4

Is a circuit breaker wired in series or in parallel with the device it is protecting?

SUMMARY

The **emf** of a battery is equal to the voltage across its terminals when the current is zero. That is, the emf is equivalent to the **open-circuit voltage** of the battery.

The **equivalent resistance** of a set of resistors connected in **series** is

$$R_{\text{eq}} = R_1 + R_2 + R_3 + \cdots \quad (28.6)$$

The **equivalent resistance** of a set of resistors connected in **parallel** is

$$\frac{1}{R_{\text{eq}}} = \frac{1}{R_1} + \frac{1}{R_2} + \frac{1}{R_3} + \cdots \quad (28.8)$$

If it is possible to combine resistors into series or parallel equivalents, the preceding two equations make it easy to determine how the resistors influence the rest of the circuit.

Circuits involving more than one loop are conveniently analyzed with the use of **Kirchhoff's rules**:

1. The sum of the currents entering any junction in an electric circuit must equal the sum of the currents leaving that junction:

$$\sum I_{\text{in}} = \sum I_{\text{out}} \quad (28.9)$$

2. The sum of the potential differences across all elements around any circuit loop must be zero:

$$\sum_{\text{closed loop}} \Delta V = 0 \quad (28.10)$$

The first rule is a statement of conservation of charge; the second is equivalent to a statement of conservation of energy.

When a resistor is traversed in the direction of the current, the change in potential ΔV across the resistor is $-IR$. When a resistor is traversed in the direction opposite the current, $\Delta V = +IR$. When a source of emf is traversed in the direction of the emf (negative terminal to positive terminal), the change in potential is $+\mathcal{E}$. When a source of emf is traversed opposite the emf (positive to negative), the change in potential is $-\mathcal{E}$. The use of these rules together with Equations 28.9 and 28.10 allows you to analyze electric circuits.

If a capacitor is charged with a battery through a resistor of resistance R , the charge on the capacitor and the current in the circuit vary in time according to

the expressions

$$q(t) = Q(1 - e^{-t/RC}) \quad (28.14)$$

$$I(t) = \frac{\mathcal{E}}{R} e^{-t/RC} \quad (28.15)$$

where $Q = C\mathcal{E}$ is the maximum charge on the capacitor. The product RC is called the **time constant** τ of the circuit. If a charged capacitor is discharged through a resistor of resistance R , the charge and current decrease exponentially in time according to the expressions

$$q(t) = Qe^{-t/RC} \quad (28.17)$$

$$I(t) = -\frac{Q}{RC} e^{-t/RC} \quad (28.18)$$

where Q is the initial charge on the capacitor and $Q/RC = I_0$ is the initial current in the circuit. Equations 28.14, 28.15, 28.17, and 28.18 permit you to analyze the current and potential differences in an RC circuit and the charge stored in the circuit's capacitor.

QUESTIONS

1. Explain the difference between load resistance in a circuit and internal resistance in a battery.
2. Under what condition does the potential difference across the terminals of a battery equal its emf? Can the terminal voltage ever exceed the emf? Explain.
3. Is the direction of current through a battery always from the negative terminal to the positive one? Explain.
4. How would you connect resistors so that the equivalent resistance is greater than the greatest individual resistance? Give an example involving three resistors.
5. How would you connect resistors so that the equivalent resistance is less than the least individual resistance? Give an example involving three resistors.
6. Given three lightbulbs and a battery, sketch as many different electric circuits as you can.
7. Which of the following are the same for each resistor in a series connection—potential difference, current, power?
8. Which of the following are the same for each resistor in a parallel connection—potential difference, current, power?
9. What advantage might there be in using two identical resistors in parallel connected in series with another identical parallel pair, rather than just using a single resistor?
10. An incandescent lamp connected to a 120-V source with a short extension cord provides more illumination than the same lamp connected to the same source with a very long extension cord. Explain why.
11. When can the potential difference across a resistor be positive?
12. In Figure 28.15, suppose the wire between points g and h is replaced by a $10\text{-}\Omega$ resistor. Explain why this change does not affect the currents calculated in Example 28.9.
13. Describe what happens to the lightbulb shown in Figure Q28.13 after the switch is closed. Assume that the capacitor has a large capacitance and is initially uncharged, and assume that the light illuminates when connected directly across the battery terminals.
14. What are the internal resistances of an ideal ammeter? of an ideal voltmeter? Do real meters ever attain these ideals?
15. Although the internal resistances of all sources of emf were neglected in the treatment of the potentiometer (Section 28.5), it is really not necessary to make this assumption. Explain why internal resistances play no role in the measurement of \mathcal{E}_x .

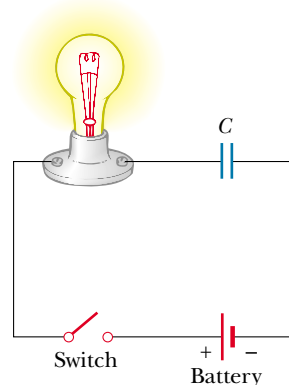

Figure Q28.13

16. Why is it dangerous to turn on a light when you are in the bathtub?
17. Suppose you fall from a building, and on your way down you grab a high-voltage wire. Assuming that you are hanging from the wire, will you be electrocuted? If the wire then breaks, should you continue to hold onto an end of the wire as you fall?
18. What advantage does 120-V operation offer over 240 V? What are its disadvantages compared with 240 V?
19. When electricians work with potentially live wires, they often use the backs of their hands or fingers to move the wires. Why do you suppose they employ this technique?
20. What procedure would you use to try to save a person who is “frozen” to a live high-voltage wire without endangering your own life?
21. If it is the current through the body that determines the seriousness of a shock, why do we see warnings of high voltage rather than high current near electrical equipment?
22. Suppose you are flying a kite when it strikes a high-voltage wire. What factors determine how great a shock you receive?
23. A series circuit consists of three identical lamps that are connected to a battery as shown in Figure Q28.23. When switch S is closed, what happens (a) to the intensities of lamps A and B, (b) to the intensity of lamp C, (c) to the current in the circuit, and (d) to the voltage across the three lamps? (e) Does the power delivered to the circuit increase, decrease, or remain the same?

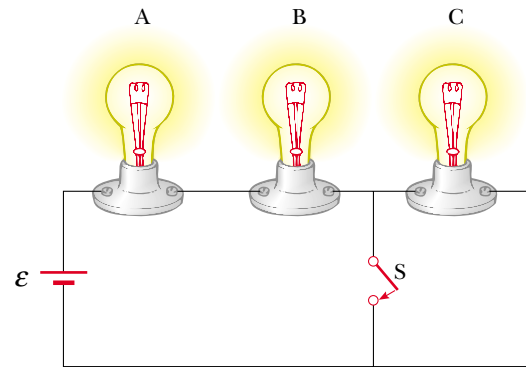

Figure Q28.23

24. If your car’s headlights are on when you start the ignition, why do they dim while the car is starting?
25. A ski resort consists of a few chair lifts and several interconnected downhill runs on the side of a mountain, with a lodge at the bottom. The lifts are analogous to batteries, and the runs are analogous to resistors. Describe how two runs can be in series. Describe how three runs can be in parallel. Sketch a junction of one lift and two runs. State Kirchhoff’s junction rule for ski resorts. One of the skiers, who happens to be carrying an altimeter, stops to warm up her toes each time she passes the lodge. State Kirchhoff’s loop rule for altitude.

PROBLEMS

1, 2, 3 = straightforward, intermediate, challenging □ = full solution available in the *Student Solutions Manual and Study Guide*
 WEB = solution posted at <http://www.saunderscollege.com/physics/> = Computer useful in solving problem = Interactive Physics
 □ = paired numerical/symbolic problems

Section 28.1 Electromotive Force

- WEB 1. A battery has an emf of 15.0 V. The terminal voltage of the battery is 11.6 V when it is delivering 20.0 W of power to an external load resistor R . (a) What is the value of R ? (b) What is the internal resistance of the battery?
2. (a) What is the current in a 5.60- Ω resistor connected to a battery that has a 0.200- Ω internal resistance if the terminal voltage of the battery is 10.0 V? (b) What is the emf of the battery?
3. Two 1.50-V batteries—with their positive terminals in the same direction—are inserted in series into the barrel of a flashlight. One battery has an internal resistance of 0.255 Ω , the other an internal resistance of 0.153 Ω . When the switch is closed, a current of 600 mA occurs in the lamp. (a) What is the lamp’s resistance? (b) What percentage of the power from the batteries appears in the batteries themselves, as represented by an increase in temperature?

4. An automobile battery has an emf of 12.6 V and an internal resistance of 0.080 Ω . The headlights have a total resistance of 5.00 Ω (assumed constant). What is the potential difference across the headlight bulbs (a) when they are the only load on the battery and (b) when the starter motor, which takes an additional 35.0 A from the battery, is operated?

Section 28.2 Resistors in Series and in Parallel

5. The current in a loop circuit that has a resistance of R_1 is 2.00 A. The current is reduced to 1.60 A when an additional resistor $R_2 = 3.00 \Omega$ is added in series with R_1 . What is the value of R_1 ?
6. (a) Find the equivalent resistance between points a and b in Figure P28.6. (b) Calculate the current in each resistor if a potential difference of 34.0 V is applied between points a and b .
7. A television repairman needs a 100- Ω resistor to repair a malfunctioning set. He is temporarily out of resistors

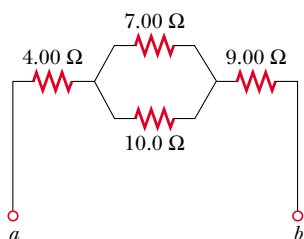

Figure P28.6

of this value. All he has in his toolbox are a $500\text{-}\Omega$ resistor and two $250\text{-}\Omega$ resistors. How can he obtain the desired resistance using the resistors he has on hand?

8. A lightbulb marked “75 W [at] 120 V” is screwed into a socket at one end of a long extension cord in which each of the two conductors has a resistance of $0.800\ \Omega$. The other end of the extension cord is plugged into a 120-V outlet. Draw a circuit diagram, and find the actual power delivered to the bulb in this circuit.

- WEB 9. Consider the circuit shown in Figure P28.9. Find (a) the current in the $20.0\text{-}\Omega$ resistor and (b) the potential difference between points a and b .

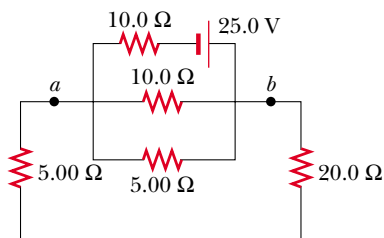

Figure P28.9

10. Four copper wires of equal length are connected in series. Their cross-sectional areas are $1.00\ \text{cm}^2$, $2.00\ \text{cm}^2$, $3.00\ \text{cm}^2$, and $5.00\ \text{cm}^2$. If a voltage of 120 V is applied to the arrangement, what is the voltage across the 2.00-cm^2 wire?
11. Three $100\text{-}\Omega$ resistors are connected as shown in Figure P28.11. The maximum power that can safely be delivered to any one resistor is 25.0 W. (a) What is the maximum voltage that can be applied to the terminals a and b ? (b) For the voltage determined in part (a), what is

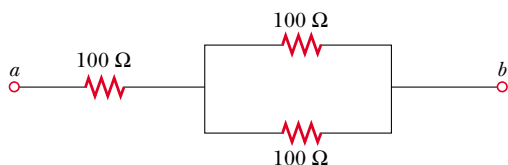

Figure P28.11

the power delivered to each resistor? What is the total power delivered?

12. Using only three resistors— $2.00\ \Omega$, $3.00\ \Omega$, and $4.00\ \Omega$ —find 17 resistance values that can be obtained with various combinations of one or more resistors. Tabulate the combinations in order of increasing resistance.
13. The current in a circuit is tripled by connecting a $500\text{-}\Omega$ resistor in parallel with the resistance of the circuit. Determine the resistance of the circuit in the absence of the $500\text{-}\Omega$ resistor.
14. The power delivered to the top part of the circuit shown in Figure P28.14 does not depend on whether the switch is opened or closed. If $R = 1.00\ \Omega$, what is R' ? Neglect the internal resistance of the voltage source.

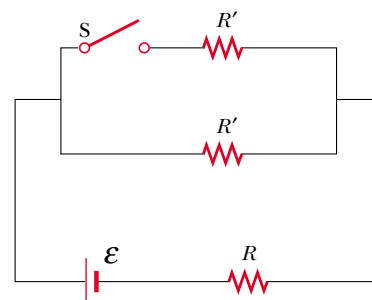

Figure P28.14

15. Calculate the power delivered to each resistor in the circuit shown in Figure P28.15.

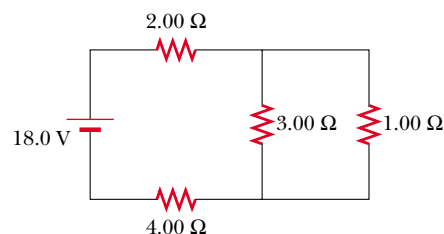

Figure P28.15

16. Two resistors connected in series have an equivalent resistance of $690\ \Omega$. When they are connected in parallel, their equivalent resistance is $150\ \Omega$. Find the resistance of each resistor.
17. In Figures 28.4 and 28.5, let $R_1 = 11.0\ \Omega$, let $R_2 = 22.0\ \Omega$, and let the battery have a terminal voltage of 33.0 V. (a) In the parallel circuit shown in Figure 28.5, which resistor uses more power? (b) Verify that the sum of the power (I^2R) used by each resistor equals the power supplied by the battery ($I\Delta V$). (c) In the series circuit, which resistor uses more power? (d) Verify that the sum of the power (I^2R) used by each resistor equals

the power supplied by the battery ($\mathcal{P} = I\Delta V$).
 (e) Which circuit configuration uses more power?

Section 28.3 Kirchhoff's Rules

Note: The currents are not necessarily in the direction shown for some circuits.

18. The ammeter shown in Figure P28.18 reads 2.00 A. Find I_1 , I_2 , and \mathcal{E} .

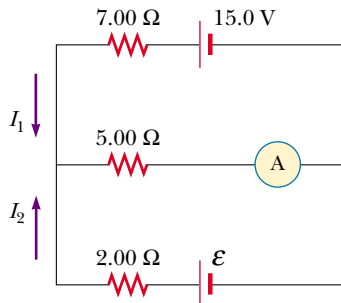

Figure P28.18

- WEB 19. Determine the current in each branch of the circuit shown in Figure P28.19.

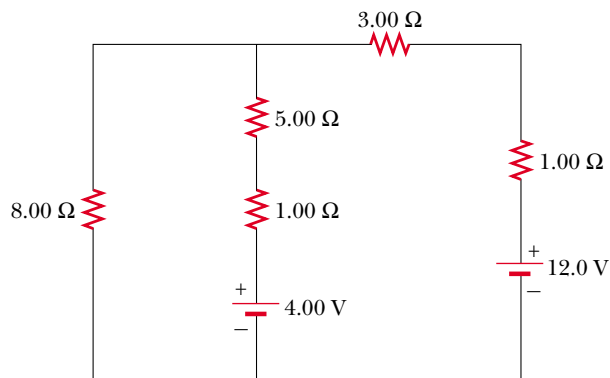

Figure P28.19 Problems 19, 20, and 21.

20. In Figure P28.19, show how to add just enough ammeters to measure every different current that is flowing. Show how to add just enough voltmeters to measure the potential difference across each resistor and across each battery.
21. The circuit considered in Problem 19 and shown in Figure P28.19 is connected for 2.00 min. (a) Find the energy supplied by each battery. (b) Find the energy delivered to each resistor. (c) Find the total amount of energy converted from chemical energy in the battery to internal energy in the circuit resistance.

22. (a) Using Kirchhoff's rules, find the current in each resistor shown in Figure P28.22 and (b) find the potential difference between points c and f . Which point is at the higher potential?

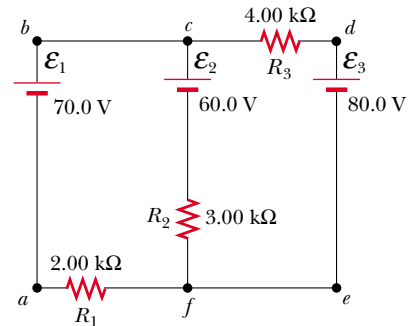

Figure P28.22

23. If $R = 1.00 \text{ k}\Omega$ and $\mathcal{E} = 250 \text{ V}$ in Figure P28.23, determine the direction and magnitude of the current in the horizontal wire between a and e .

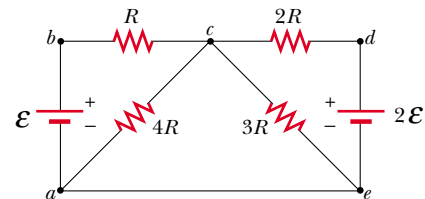

Figure P28.23

24. In the circuit of Figure P28.24, determine the current in each resistor and the voltage across the 200-Ω resistor.

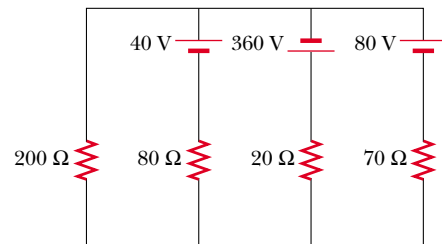

Figure P28.24

25. A dead battery is charged by connecting it to the live battery of another car with jumper cables (Fig. P28.25). Determine the current in the starter and in the dead battery.

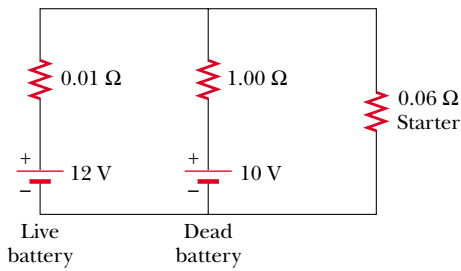

Figure P28.25

26. For the network shown in Figure P28.26, show that the resistance $R_{ab} = \frac{27}{17} \Omega$.

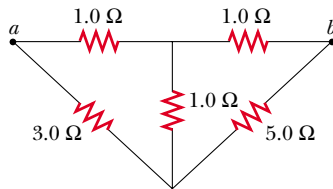

Figure P28.26

27. For the circuit shown in Figure P28.27, calculate (a) the current in the 2.00-Ω resistor and (b) the potential difference between points a and b .

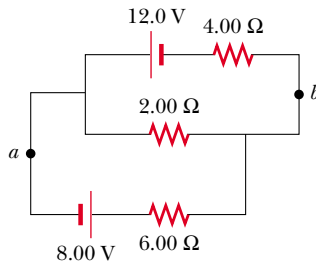

Figure P28.27

28. Calculate the power delivered to each of the resistors shown in Figure P28.28.

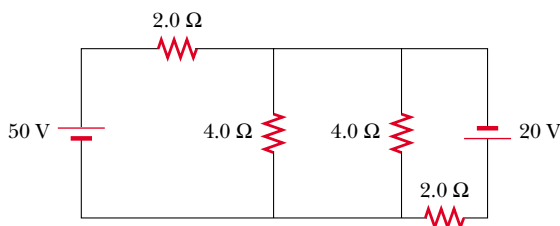

Figure P28.28

Section 28.4 RC Circuits

- WEB 29. Consider a series RC circuit (see Fig. 28.16) for which $R = 1.00 \text{ M}\Omega$, $C = 5.00 \mu\text{F}$, and $\mathcal{E} = 30.0 \text{ V}$. Find (a) the time constant of the circuit and (b) the maximum charge on the capacitor after the switch is closed. (c) If the switch is closed at $t = 0$, find the current in the resistor 10.0 s later.
30. A 2.00-nF capacitor with an initial charge of $5.10 \mu\text{C}$ is discharged through a 1.30-kΩ resistor. (a) Calculate the current through the resistor 9.00 μs after the resistor is connected across the terminals of the capacitor. (b) What charge remains on the capacitor after 8.00 μs? (c) What is the maximum current in the resistor?
31. A fully charged capacitor stores energy U_0 . How much energy remains when its charge has decreased to half its original value?
32. In the circuit of Figure P28.32, switch S has been open for a long time. It is then suddenly closed. Determine the time constant (a) before the switch is closed and (b) after the switch is closed. (c) If the switch is closed at $t = 0$, determine the current through it as a function of time.

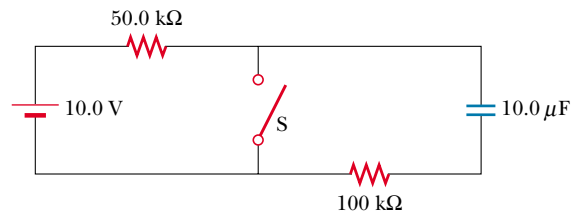

Figure P28.32

33. The circuit shown in Figure P28.33 has been connected for a long time. (a) What is the voltage across the capacitor? (b) If the battery is disconnected, how long does it take the capacitor to discharge to one-tenth its initial voltage?

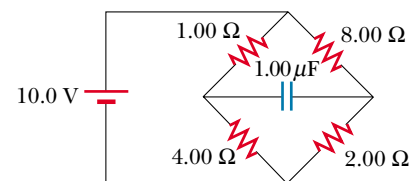

Figure P28.33

34. A 4.00-MΩ resistor and a 3.00-μF capacitor are connected in series with a 12.0-V power supply. (a) What is the time constant for the circuit? (b) Express the current in the circuit and the charge on the capacitor as functions of time.

35. Dielectric materials used in the manufacture of capacitors are characterized by conductivities that are small but not zero. Therefore, a charged capacitor slowly loses its charge by “leaking” across the dielectric. If a certain $3.60\text{-}\mu\text{F}$ capacitor leaks charge such that the potential difference decreases to half its initial value in 4.00 s , what is the equivalent resistance of the dielectric?
36. Dielectric materials used in the manufacture of capacitors are characterized by conductivities that are small but not zero. Therefore, a charged capacitor slowly loses its charge by “leaking” across the dielectric. If a capacitor having capacitance C leaks charge such that the potential difference decreases to half its initial value in a time t , what is the equivalent resistance of the dielectric?
37. A capacitor in an RC circuit is charged to 60.0% of its maximum value in 0.900 s . What is the time constant of the circuit?

(Optional)

Section 28.5 Electrical Instruments

38. A typical galvanometer, which requires a current of 1.50 mA for full-scale deflection and has a resistance of $75.0\ \Omega$, can be used to measure currents of much greater values. A relatively small shunt resistor is wired in parallel with the galvanometer (refer to Fig. 28.24a) so that an operator can measure large currents without causing damage to the galvanometer. Most of the current then flows through the shunt resistor. Calculate the value of the shunt resistor that enables the galvanometer to be used to measure a current of 1.00 A at full-scale deflection. (*Hint:* Use Kirchhoff’s rules.)
39. The galvanometer described in the preceding problem can be used to measure voltages. In this case a large resistor is wired in series with the galvanometer in a way similar to that shown in Figure 28.24b. This arrangement, in effect, limits the current that flows through the galvanometer when large voltages are applied. Most of the potential drop occurs across the resistor placed in series. Calculate the value of the resistor that enables the galvanometer to measure an applied voltage of 25.0 V at full-scale deflection.
40. A galvanometer with a full-scale sensitivity of 1.00 mA requires a $900\text{-}\Omega$ series resistor to make a voltmeter reading full scale when 1.00 V is measured across the terminals. What series resistor is required to make the same galvanometer into a 50.0-V (full-scale) voltmeter?
41. Assume that a galvanometer has an internal resistance of $60.0\ \Omega$ and requires a current of 0.500 mA to produce full-scale deflection. What resistance must be connected in parallel with the galvanometer if the combination is to serve as an ammeter that has a full-scale deflection for a current of 0.100 A ?
42. A Wheatstone bridge of the type shown in Figure 28.25 is used to make a precise measurement of the resistance of a wire connector. If $R_3 = 1.00\text{ k}\Omega$ and the bridge is balanced by adjusting R_1 such that $R_1 = 2.50R_2$, what is R_x ?
43. Consider the case in which the Wheatstone bridge shown in Figure 28.25 is unbalanced. Calculate the current through the galvanometer when $R_x = R_3 = 7.00\ \Omega$, $R_2 = 21.0\ \Omega$, and $R_1 = 14.0\ \Omega$. Assume that the voltage across the bridge is 70.0 V , and neglect the galvanometer’s resistance.
44. **Review Problem.** A Wheatstone bridge can be used to measure the strain ($\Delta L/L_i$) of a wire (see Section 12.4), where L_i is the length before stretching, L is the length after stretching, and $\Delta L = L - L_i$. Let $\alpha = \Delta L/L_i$. Show that the resistance is $R = R_i(1 + 2\alpha + \alpha^2)$ for any length, where $R_i = \rho L_i/A_i$. Assume that the resistivity and volume of the wire stay constant.
45. Consider the potentiometer circuit shown in Figure 28.27. If a standard battery with an emf of 1.0186 V is used in the circuit and the resistance between a and d is $36.0\ \Omega$, the galvanometer reads zero. If the standard battery is replaced by an unknown emf, the galvanometer reads zero when the resistance is adjusted to $48.0\ \Omega$. What is the value of the emf?
46. *Meter loading.* Work this problem to five-digit precision. Refer to Figure P28.46. (a) When a $180.00\text{-}\Omega$ resistor is put across a battery with an emf of 6.0000 V and an internal resistance of $20.000\ \Omega$, what current flows in the resistor? What will be the potential difference across it? (b) Suppose now that an ammeter with a resistance of $0.50000\ \Omega$ and a voltmeter with a resistance of

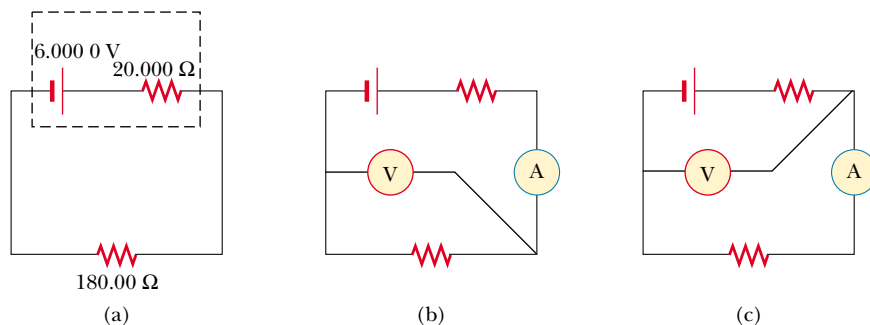
**Figure P28.46**

$20\,000\ \Omega$ are added to the circuit, as shown in Figure P28.46b. Find the reading of each. (c) One terminal of one wire is moved, as shown in Figure P28.46c. Find the new meter readings.

(Optional)

Section 28.6 Household Wiring and Electrical Safety

- WEB 47.** An electric heater is rated at $1\,500\ \text{W}$, a toaster at $750\ \text{W}$, and an electric grill at $1\,000\ \text{W}$. The three appliances are connected to a common 120-V circuit.
- (a) How much current does each draw? (b) Is a 25.0-A circuit breaker sufficient in this situation? Explain your answer.
- 48.** An 8.00-ft extension cord has two 18-gauge copper wires, each with a diameter of $1.024\ \text{mm}$. What is the I^2R loss in this cord when it carries a current of (a) $1.00\ \text{A}$? (b) $10.0\ \text{A}$?
- 49.** Sometimes aluminum wiring has been used instead of copper for economic reasons. According to the National Electrical Code, the maximum allowable current for 12-gauge copper wire with rubber insulation is $20\ \text{A}$. What should be the maximum allowable current in a 12-gauge aluminum wire if it is to have the same I^2R loss per unit length as the copper wire?
- 50.** Turn on your desk lamp. Pick up the cord with your thumb and index finger spanning its width. (a) Compute an order-of-magnitude estimate for the current that flows through your hand. You may assume that at a typical instant the conductor inside the lamp cord next to your thumb is at potential $\sim 10^2\ \text{V}$ and that the conductor next to your index finger is at ground potential ($0\ \text{V}$). The resistance of your hand depends strongly on the thickness and moisture content of the outer layers of your skin. Assume that the resistance of your hand between fingertip and thumb tip is $\sim 10^4\ \Omega$. You may model the cord as having rubber insulation. State the other quantities you measure or estimate and their values. Explain your reasoning. (b) Suppose that your body is isolated from any other charges or currents. In order-of-magnitude terms, describe the potential of your thumb where it contacts the cord and the potential of your finger where it touches the cord.

ADDITIONAL PROBLEMS

- 51.** Four 1.50-V AA batteries in series are used to power a transistor radio. If the batteries can provide a total charge of $240\ \text{C}$, how long will they last if the radio has a resistance of $200\ \Omega$?
- 52.** A battery has an emf of $9.20\ \text{V}$ and an internal resistance of $1.20\ \Omega$. (a) What resistance across the battery will extract from it a power of $12.8\ \text{W}$? (b) a power of $21.2\ \text{W}$?
- 53.** Calculate the potential difference between points a and b in Figure P28.53, and identify which point is at the higher potential.

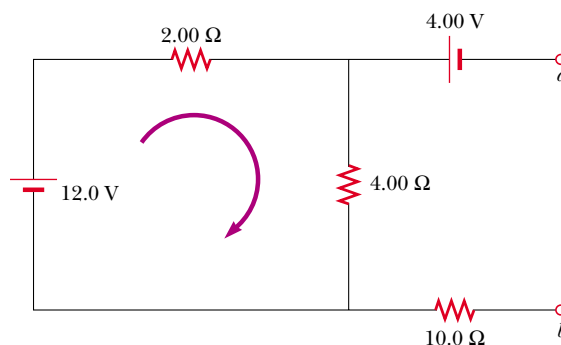

Figure P28.53

- 54.** A $10.0\text{-}\mu\text{F}$ capacitor is charged by a 10.0-V battery through a resistance R . The capacitor reaches a potential difference of $4.00\ \text{V}$ at a time $3.00\ \text{s}$ after charging begins. Find R .
- 55.** When two unknown resistors are connected in series with a battery, $225\ \text{W}$ is delivered to the combination with a total current of $5.00\ \text{A}$. For the same total current, $50.0\ \text{W}$ is delivered when the resistors are connected in parallel. Determine the values of the two resistors.
- 56.** When two unknown resistors are connected in series with a battery, a total power \mathcal{P}_s is delivered to the combination with a total current of I . For the same total current, a total power \mathcal{P}_p is delivered when the resistors are connected in parallel. Determine the values of the two resistors.
- 57.** A battery has an emf \mathcal{E} and internal resistance r . A variable resistor R is connected across the terminals of the battery. Determine the value of R such that (a) the potential difference across the terminals is a maximum, (b) the current in the circuit is a maximum, (c) the power delivered to the resistor is a maximum.
- 58.** A power supply has an open-circuit voltage of $40.0\ \text{V}$ and an internal resistance of $2.00\ \Omega$. It is used to charge two storage batteries connected in series, each having an emf of $6.00\ \text{V}$ and internal resistance of $0.300\ \Omega$. If the charging current is to be $4.00\ \text{A}$, (a) what additional resistance should be added in series? (b) Find the power delivered to the internal resistance of the supply, the I^2R loss in the batteries, and the power delivered to the added series resistance. (c) At what rate is the chemical energy in the batteries increasing?
- 59.** The value of a resistor R is to be determined using the ammeter-voltmeter setup shown in Figure P28.59. The ammeter has a resistance of $0.500\ \Omega$, and the voltmeter has a resistance of $20\,000\ \Omega$. Within what range of actual values of R will the measured values be correct, to within 5.00% , if the measurement is made using (a) the circuit shown in Figure P28.59a? (b) the circuit shown in Figure P28.59b?

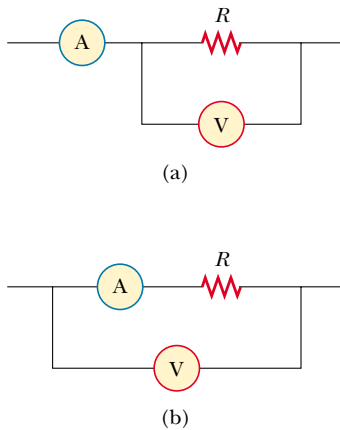

Figure P28.59

60. A battery is used to charge a capacitor through a resistor, as shown in Figure 28.16. Show that half the energy supplied by the battery appears as internal energy in the resistor and that half is stored in the capacitor.
61. The values of the components in a simple series RC circuit containing a switch (Fig. 28.16) are $C = 1.00 \mu\text{F}$, $R = 2.00 \times 10^6 \Omega$, and $\mathcal{E} = 10.0 \text{ V}$. At the instant 10.0 s after the switch is closed, calculate (a) the charge on the capacitor, (b) the current in the resistor, (c) the rate at which energy is being stored in the capacitor, and (d) the rate at which energy is being delivered by the battery.
62. The switch in Figure P28.62a closes when $\Delta V_c > 2\Delta V/3$ and opens when $\Delta V_c < \Delta V/3$. The voltmeter reads a voltage as plotted in Figure P28.62b. What is the period T of the waveform in terms of R_A , R_B , and C ?

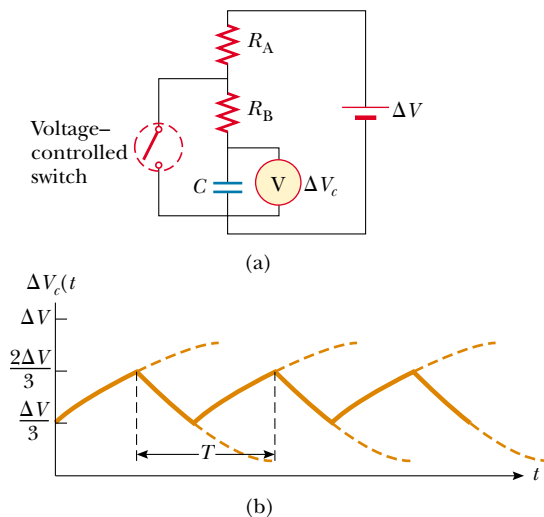

Figure P28.62

63. Three 60.0-W , 120-V lightbulbs are connected across a 120-V power source, as shown in Figure P28.63. Find (a) the total power delivered to the three bulbs and (b) the voltage across each. Assume that the resistance of each bulb conforms to Ohm's law (even though in reality the resistance increases markedly with current).

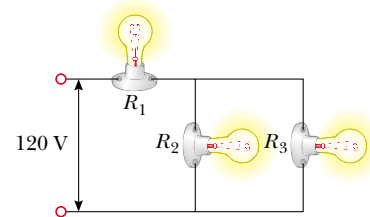

Figure P28.63

64. Design a multirange voltmeter capable of full-scale deflection for 20.0 V , 50.0 V , and 100 V . Assume that the meter movement is a galvanometer that has a resistance of 60.0Ω and gives a full-scale deflection for a current of 1.00 mA .
65. Design a multirange ammeter capable of full-scale deflection for 25.0 mA , 50.0 mA , and 100 mA . Assume that the meter movement is a galvanometer that has a resistance of 25.0Ω and gives a full-scale deflection for 1.00 mA .
66. A particular galvanometer serves as a 2.00-V full-scale voltmeter when a $2500\text{-}\Omega$ resistor is connected in series with it. It serves as a 0.500-A full-scale ammeter when a $0.220\text{-}\Omega$ resistor is connected in parallel with it. Determine the internal resistance of the galvanometer and the current required to produce full-scale deflection.
67. In Figure P28.67, suppose that the switch has been closed for a length of time sufficiently long for the capacitor to become fully charged. (a) Find the steady-state current in each resistor. (b) Find the charge Q on the capacitor. (c) The switch is opened at $t = 0$. Write an equation for the current I_{R_2} in R_2 as a function of time, and (d) find the time that it takes for the charge on the capacitor to fall to one-fifth its initial value.

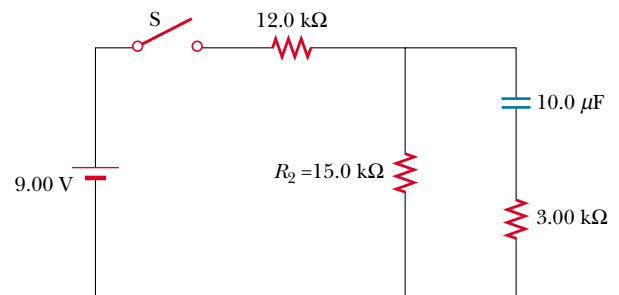

Figure P28.67

68. The circuit shown in Figure P28.68 is set up in the laboratory to measure an unknown capacitance C with the use of a voltmeter of resistance $R = 10.0 \text{ M}\Omega$ and a battery whose emf is 6.19 V . The data given in the table below are the measured voltages across the capacitor as a function of time, where $t = 0$ represents the time at which the switch is opened. (a) Construct a graph of $\ln(\mathcal{E}/\Delta V)$ versus t , and perform a linear least-squares fit to the data. (b) From the slope of your graph, obtain a value for the time constant of the circuit and a value for the capacitance.

ΔV (V)	t (s)	$\ln(\mathcal{E}/\Delta V)$
6.19	0	
5.55	4.87	
4.93	11.1	
4.34	19.4	
3.72	30.8	
3.09	46.6	
2.47	67.3	
1.83	102.2	

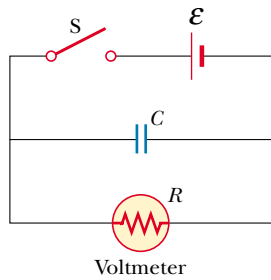

Figure P28.68

69. (a) Using symmetry arguments, show that the current through any resistor in the configuration of Figure P28.69 is either $I/3$ or $I/6$. All resistors have the same resistance r . (b) Show that the equivalent resistance between points a and b is $(5/6)r$.

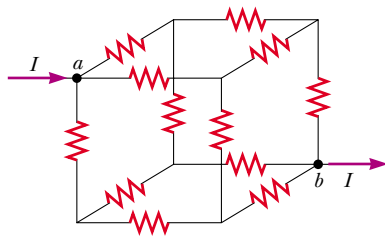

Figure P28.69

70. The student engineer of a campus radio station wishes to verify the effectiveness of the lightning rod on the an-

tenna mast (Fig. P28.70). The unknown resistance R_x is between points C and E . Point E is a true ground but is inaccessible for direct measurement since this stratum is several meters below the Earth's surface. Two identical rods are driven into the ground at A and B , introducing an unknown resistance R_y . The procedure is as follows. Measure resistance R_1 between points A and B , then connect A and B with a heavy conducting wire and measure resistance R_2 between points A and C . (a) Derive a formula for R_x in terms of the observable resistances R_1 and R_2 . (b) A satisfactory ground resistance would be $R_x < 2.00 \Omega$. Is the grounding of the station adequate if measurements give $R_1 = 13.0 \Omega$ and $R_2 = 6.00 \Omega$?

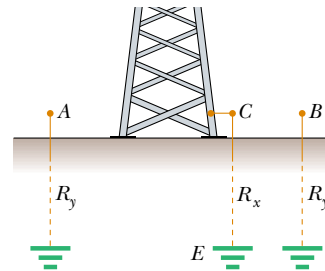

Figure P28.70

71. Three $2.00\text{-}\Omega$ resistors are connected as shown in Figure P28.71. Each can withstand a maximum power of 32.0 W without becoming excessively hot. Determine the maximum power that can be delivered to the combination of resistors.

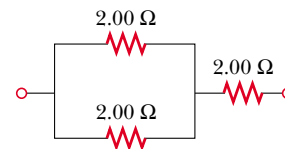

Figure P28.71

72. The circuit in Figure P28.72 contains two resistors, $R_1 = 2.00 \text{ k}\Omega$ and $R_2 = 3.00 \text{ k}\Omega$, and two capacitors, $C_1 = 2.00 \mu\text{F}$ and $C_2 = 3.00 \mu\text{F}$, connected to a battery with emf $\mathcal{E} = 120 \text{ V}$. If no charges exist on the capacitors before switch S is closed, determine the charges q_1 and q_2 on capacitors C_1 and C_2 , respectively, after the switch is closed. (Hint: First reconstruct the circuit so that it becomes a simple RC circuit containing a single resistor and single capacitor in series, connected to the battery, and then determine the total charge q stored in the equivalent circuit.)

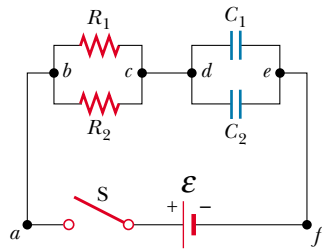

Figure P28.72

73. Assume that you have a battery of emf \mathcal{E} and three identical lightbulbs, each having constant resistance R . What is the total power from the battery if the bulbs are connected (a) in series? (b) in parallel? (c) For which connection do the bulbs shine the brightest?

ANSWERS TO QUICK QUIZZES

- 28.1 Bulb R_1 becomes brighter. Connecting b to c “shorts out” bulb R_2 and changes the total resistance of the circuit from $R_1 + R_2$ to just R_1 . Because the resistance has decreased (and the potential difference supplied by the battery does not change), the current through the battery increases. This means that the current through bulb R_1 increases, and bulb R_1 glows more brightly. Bulb R_2 goes out because the new piece of wire provides an almost resistance-free path for the current; hence, essentially zero current exists in bulb R_2 .
- 28.2 Adding another series resistor increases the total resistance of the circuit and thus reduces the current in the battery. The potential difference across the battery terminals would increase because the reduced current results in a smaller voltage decrease across the internal resistance.

If the second resistor were connected in parallel, the total resistance of the circuit would decrease, and an increase in current through the battery would result. The potential difference across the terminals would decrease because the increased current results in a greater voltage decrease across the internal resistance.

- 28.3 They must be in parallel because if one burns out, the other continues to operate. If they were in series, one failed headlamp would interrupt the current throughout the entire circuit, including the other headlamp.
- 28.4 Because the circuit breaker trips and opens the circuit when the current in that circuit exceeds a certain preset value, it must be in series to sense the appropriate current (see Fig. 28.28).