



## PUZZLER

Before this vending machine will deliver its product, it conducts several tests on the coins being inserted. How can it determine what material the coins are made of without damaging them and without making the customer wait a long time for the results? (George Semple)

# Faraday's Law

chapter

# 31

## Chapter Outline

- 31.1** Faraday's Law of Induction
- 31.2** Motional emf
- 31.3** Lenz's Law
- 31.4** Induced emf and Electric Fields
- 31.5** (Optional) Generators and Motors
- 31.6** (Optional) Eddy Currents
- 31.7** Maxwell's Wonderful Equations

The focus of our studies in electricity and magnetism so far has been the electric fields produced by stationary charges and the magnetic fields produced by moving charges. This chapter deals with electric fields produced by changing magnetic fields.

Experiments conducted by Michael Faraday in England in 1831 and independently by Joseph Henry in the United States that same year showed that an emf can be induced in a circuit by a changing magnetic field. As we shall see, an emf (and therefore a current as well) can be induced in many ways—for instance, by moving a closed loop of wire into a region where a magnetic field exists. The results of these experiments led to a very basic and important law of electromagnetism known as *Faraday's law of induction*. This law states that the magnitude of the emf induced in a circuit equals the time rate of change of the magnetic flux through the circuit.

With the treatment of Faraday's law, we complete our introduction to the fundamental laws of electromagnetism. These laws can be summarized in a set of four equations called *Maxwell's equations*. Together with the *Lorentz force law*, which we discuss briefly, they represent a complete theory for describing the interaction of charged objects. Maxwell's equations relate electric and magnetic fields to each other and to their ultimate source, namely, electric charges.

### 31.1 FARADAY'S LAW OF INDUCTION

To see how an emf can be induced by a changing magnetic field, let us consider a loop of wire connected to a galvanometer, as illustrated in Figure 31.1. When a magnet is moved toward the loop, the galvanometer needle deflects in one direction, arbitrarily shown to the right in Figure 31.1a. When the magnet is moved away from the loop, the needle deflects in the opposite direction, as shown in Figure 31.1c. When the magnet is held stationary relative to the loop (Fig. 31.1b), no deflection is observed. Finally, if the magnet is held stationary and the loop is moved either toward or away from it, the needle deflects. From these observations, we conclude that the loop “knows” that the magnet is moving relative to it because it experiences a change in magnetic field. Thus, it seems that a relationship exists between current and changing magnetic field.

These results are quite remarkable in view of the fact that **a current is set up even though no batteries are present in the circuit!** We call such a current an *induced current* and say that it is produced by an *induced emf*.

Now let us describe an experiment conducted by Faraday<sup>1</sup> and illustrated in Figure 31.2. A primary coil is connected to a switch and a battery. The coil is wrapped around a ring, and a current in the coil produces a magnetic field when the switch is closed. A secondary coil also is wrapped around the ring and is connected to a galvanometer. No battery is present in the secondary circuit, and the secondary coil is not connected to the primary coil. Any current detected in the secondary circuit must be induced by some external agent.

Initially, you might guess that no current is ever detected in the secondary circuit. However, something quite amazing happens when the switch in the primary



A demonstration of electromagnetic induction. A changing potential difference is applied to the lower coil. An emf is induced in the upper coil as indicated by the illuminated lamp. What happens to the lamp's intensity as the upper coil is moved over the vertical tube? (Courtesy of Central Scientific Company)

<sup>1</sup> A physicist named J. D. Colladon was the first to perform the moving-magnet experiment. To minimize the effect of the changing magnetic field on his galvanometer, he placed the meter in an adjacent room. Thus, as he moved the magnet in the loop, he could not see the meter needle deflecting. By the time he returned next door to read the galvanometer, the needle was back to zero because he had stopped moving the magnet. Unfortunately for Colladon, there must be relative motion between the loop and the magnet for an induced emf and a corresponding induced current to be observed. Thus, physics students learn Faraday's law of induction rather than “Colladon's law of induction.”

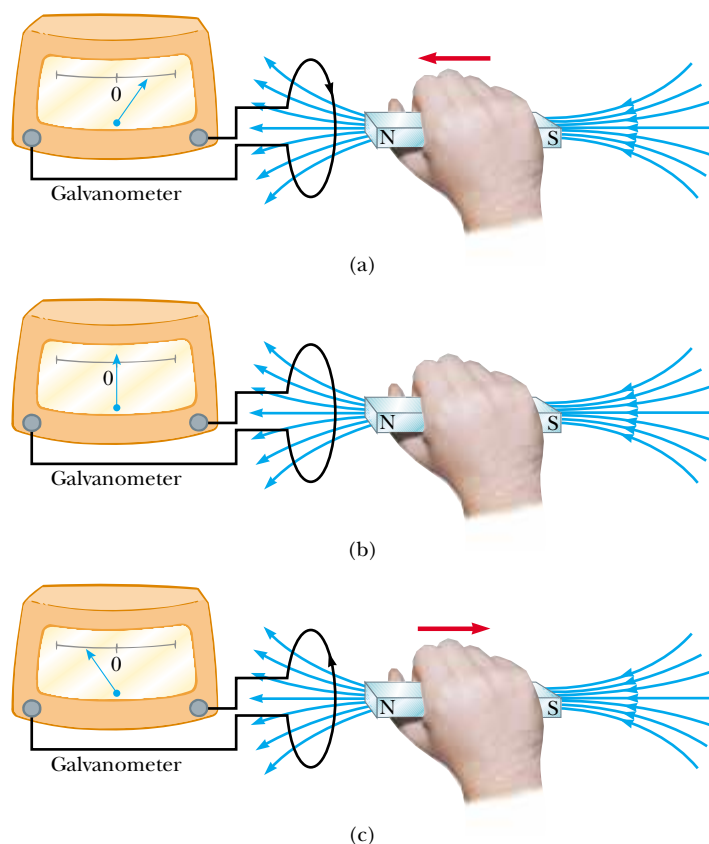

**Figure 31.1** (a) When a magnet is moved toward a loop of wire connected to a galvanometer, the galvanometer deflects as shown, indicating that a current is induced in the loop. (b) When the magnet is held stationary, there is no induced current in the loop, even when the magnet is inside the loop. (c) When the magnet is moved away from the loop, the galvanometer deflects in the opposite direction, indicating that the induced current is opposite that shown in part (a). Changing the direction of the magnet's motion changes the direction of the current induced by that motion.

circuit is either suddenly closed or suddenly opened. At the instant the switch is closed, the galvanometer needle deflects in one direction and then returns to zero. At the instant the switch is opened, the needle deflects in the opposite direction and again returns to zero. Finally, the galvanometer reads zero when there is either a steady current or no current in the primary circuit. The key to under-

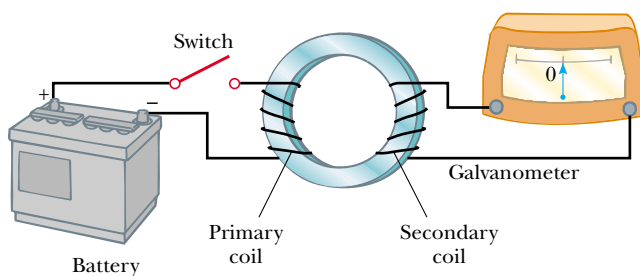

**Figure 31.2** Faraday's experiment. When the switch in the primary circuit is closed, the galvanometer in the secondary circuit deflects momentarily. The emf induced in the secondary circuit is caused by the changing magnetic field through the secondary coil.



**Michael Faraday (1791–1867)**

Faraday, a British physicist and chemist, is often regarded as the greatest experimental scientist of the 1800s. His many contributions to the study of electricity include the invention of the electric motor, electric generator, and transformer, as well as the discovery of electromagnetic induction and the laws of electrolysis. Greatly influenced by religion, he refused to work on the development of poison gas for the British military. (By kind permission of the President and Council of the Royal Society)

standing what happens in this experiment is to first note that when the switch is closed, the current in the primary circuit produces a magnetic field in the region of the circuit, and it is this magnetic field that penetrates the secondary circuit. Furthermore, when the switch is closed, the magnetic field produced by the current in the primary circuit changes from zero to some value over some finite time, and it is this changing field that induces a current in the secondary circuit.

As a result of these observations, Faraday concluded that **an electric current can be induced in a circuit (the secondary circuit in our setup) by a changing magnetic field.** The induced current exists for only a short time while the magnetic field through the secondary coil is changing. Once the magnetic field reaches a steady value, the current in the secondary coil disappears. In effect, the secondary circuit behaves as though a source of emf were connected to it for a short time. It is customary to say that **an induced emf is produced in the secondary circuit by the changing magnetic field.**

The experiments shown in Figures 31.1 and 31.2 have one thing in common: In each case, an emf is induced in the circuit when the magnetic flux through the circuit changes with time. In general,

the emf induced in a circuit is directly proportional to the time rate of change of the magnetic flux through the circuit.

This statement, known as **Faraday's law of induction**, can be written

Faraday's law

$$\mathcal{E} = -\frac{d\Phi_B}{dt} \quad (31.1)$$

where  $\Phi_B = \int \mathbf{B} \cdot d\mathbf{A}$  is the magnetic flux through the circuit (see Section 30.5).

If the circuit is a coil consisting of  $N$  loops all of the same area and if  $\Phi_B$  is the flux through one loop, an emf is induced in every loop; thus, the total induced emf in the coil is given by the expression

$$\mathcal{E} = -N \frac{d\Phi_B}{dt} \quad (31.2)$$

The negative sign in Equations 31.1 and 31.2 is of important physical significance, which we shall discuss in Section 31.3.

Suppose that a loop enclosing an area  $A$  lies in a uniform magnetic field  $\mathbf{B}$ , as shown in Figure 31.3. The magnetic flux through the loop is equal to  $BA \cos \theta$ ;

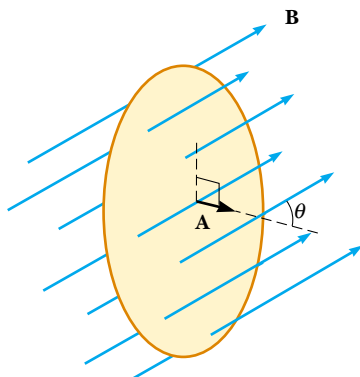

**Figure 31.3** A conducting loop that encloses an area  $A$  in the presence of a uniform magnetic field  $\mathbf{B}$ . The angle between  $\mathbf{B}$  and the normal to the loop is  $\theta$ .

hence, the induced emf can be expressed as

$$\mathcal{E} = -\frac{d}{dt}(BA \cos \theta) \quad (31.3)$$

From this expression, we see that an emf can be induced in the circuit in several ways:

- The magnitude of  $\mathbf{B}$  can change with time.
- The area enclosed by the loop can change with time.
- The angle  $\theta$  between  $\mathbf{B}$  and the normal to the loop can change with time.
- Any combination of the above can occur.

### Quick Quiz 31.1

Equation 31.3 can be used to calculate the emf induced when the north pole of a magnet is moved toward a loop of wire, along the axis perpendicular to the plane of the loop passing through its center. What changes are necessary in the equation when the south pole is moved toward the loop?

### Some Applications of Faraday's Law

The ground fault interrupter (GFI) is an interesting safety device that protects users of electrical appliances against electric shock. Its operation makes use of Faraday's law. In the GFI shown in Figure 31.4, wire 1 leads from the wall outlet to the appliance to be protected, and wire 2 leads from the appliance back to the wall outlet. An iron ring surrounds the two wires, and a sensing coil is wrapped around part of the ring. Because the currents in the wires are in opposite directions, the net magnetic flux through the sensing coil due to the currents is zero. However, if the return current in wire 2 changes, the net magnetic flux through the sensing coil is no longer zero. (This can happen, for example, if the appliance gets wet, enabling current to leak to ground.) Because household current is alternating (meaning that its direction keeps reversing), the magnetic flux through the sensing coil changes with time, inducing an emf in the coil. This induced emf is used to trigger a circuit breaker, which stops the current before it is able to reach a harmful level.

Another interesting application of Faraday's law is the production of sound in an electric guitar (Fig. 31.5). The coil in this case, called the *pickup coil*, is placed near the vibrating guitar string, which is made of a metal that can be magnetized. A permanent magnet inside the coil magnetizes the portion of the string nearest

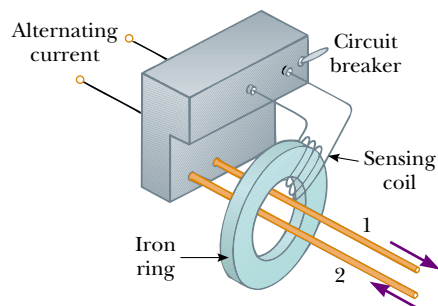

**Figure 31.4** Essential components of a ground fault interrupter.

### QuickLab

A cassette tape is made up of tiny particles of metal oxide attached to a long plastic strip. A current in a small conducting loop magnetizes the particles in a pattern related to the music being recorded. During playback, the tape is moved past a second small loop (inside the playback head) and induces a current that is then amplified. Pull a strip of tape out of a cassette (one that you don't mind recording over) and see if it is attracted or repelled by a refrigerator magnet. If you don't have a cassette, try this with an old floppy disk you are ready to trash.



This electric range cooks food on the basis of the principle of induction. An oscillating current is passed through a coil placed below the cooking surface, which is made of a special glass. The current produces an oscillating magnetic field, which induces a current in the cooking utensil. Because the cooking utensil has some electrical resistance, the electrical energy associated with the induced current is transformed to internal energy, causing the utensil and its contents to become hot. (Courtesy of Corning, Inc.)

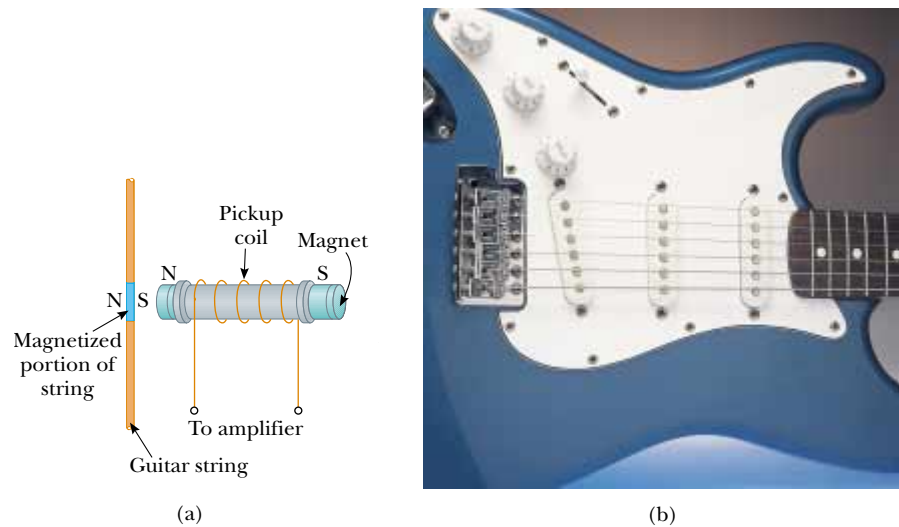

**Figure 31.5** (a) In an electric guitar, a vibrating string induces an emf in a pickup coil. (b) The circles beneath the metallic strings of this electric guitar detect the notes being played and send this information through an amplifier and into speakers. (A switch on the guitar allows the musician to select which set of six is used.) How does a guitar “pickup” sense what music is being played? (b, Charles D. Winters)

the coil. When the string vibrates at some frequency, its magnetized segment produces a changing magnetic flux through the coil. The changing flux induces an emf in the coil that is fed to an amplifier. The output of the amplifier is sent to the loudspeakers, which produce the sound waves we hear.

### EXAMPLE 31.1 One Way to Induce an emf in a Coil

A coil consists of 200 turns of wire having a total resistance of  $2.0\ \Omega$ . Each turn is a square of side 18 cm, and a uniform magnetic field directed perpendicular to the plane of the coil is turned on. If the field changes linearly from 0 to 0.50 T in 0.80 s, what is the magnitude of the induced emf in the coil while the field is changing?

**Solution** The area of one turn of the coil is  $(0.18\ \text{m})^2 = 0.0324\ \text{m}^2$ . The magnetic flux through the coil at  $t = 0$  is zero because  $B = 0$  at that time. At  $t = 0.80\ \text{s}$ , the magnetic flux through one turn is  $\Phi_B = BA = (0.50\ \text{T})(0.0324\ \text{m}^2) = 0.0162\ \text{T}\cdot\text{m}^2$ . Therefore, the magnitude of the induced emf

is, from Equation 31.2,

$$|\mathcal{E}| = \frac{N\Delta\Phi_B}{\Delta t} = \frac{200(0.0162\ \text{T}\cdot\text{m}^2 - 0\ \text{T}\cdot\text{m}^2)}{0.80\ \text{s}} = 4.1\ \text{T}\cdot\text{m}^2/\text{s} = 4.1\ \text{V}$$

You should be able to show that  $1\ \text{T}\cdot\text{m}^2/\text{s} = 1\ \text{V}$ .

**Exercise** What is the magnitude of the induced current in the coil while the field is changing?

**Answer** 2.0 A.

### EXAMPLE 31.2 An Exponentially Decaying B Field

A loop of wire enclosing an area  $A$  is placed in a region where the magnetic field is perpendicular to the plane of the loop. The magnitude of  $\mathbf{B}$  varies in time according to the expression  $B = B_{\text{max}}e^{-at}$ , where  $a$  is some constant. That is, at  $t = 0$  the field is  $B_{\text{max}}$ , and for  $t > 0$ , the field decreases exponen-

tially (Fig. 31.6). Find the induced emf in the loop as a function of time.

**Solution** Because  $\mathbf{B}$  is perpendicular to the plane of the loop, the magnetic flux through the loop at time  $t > 0$  is

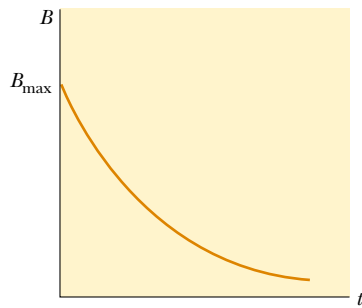

**Figure 31.6** Exponential decrease in the magnitude of the magnetic field with time. The induced emf and induced current vary with time in the same way.

$$\Phi_B = BA \cos 0 = AB_{\max} e^{-at}$$

Because  $AB_{\max}$  and  $a$  are constants, the induced emf calculated from Equation 31.1 is

$$\mathcal{E} = -\frac{d\Phi_B}{dt} = -AB_{\max} \frac{d}{dt} e^{-at} = aAB_{\max} e^{-at}$$

This expression indicates that the induced emf decays exponentially in time. Note that the maximum emf occurs at  $t = 0$ , where  $\mathcal{E}_{\max} = aAB_{\max}$ . The plot of  $\mathcal{E}$  versus  $t$  is similar to the  $B$ -versus- $t$  curve shown in Figure 31.6.

### CONCEPTUAL EXAMPLE 31.3 What Is Connected to What?

Two bulbs are connected to opposite sides of a loop of wire, as shown in Figure 31.7. A decreasing magnetic field (confined to the circular area shown in the figure) induces an emf in the loop that causes the two bulbs to light. What happens to the brightness of the bulbs when the switch is closed?

**Solution** Bulb 1 glows brighter, and bulb 2 goes out. Once the switch is closed, bulb 1 is in the large loop consisting of the wire to which it is attached and the wire connected to the switch. Because the changing magnetic flux is completely enclosed within this loop, a current exists in bulb 1. Bulb 1 now glows brighter than before the switch was closed because it is

now the only resistance in the loop. As a result, the current in bulb 1 is greater than when bulb 2 was also in the loop.

Once the switch is closed, bulb 2 is in the loop consisting of the wires attached to it and those connected to the switch. There is no changing magnetic flux through this loop and hence no induced emf.

**Exercise** What would happen if the switch were in a wire located to the left of bulb 1?

**Answer** Bulb 1 would go out, and bulb 2 would glow brighter.

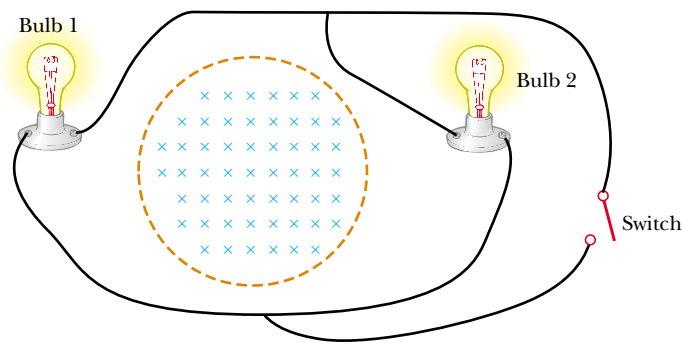
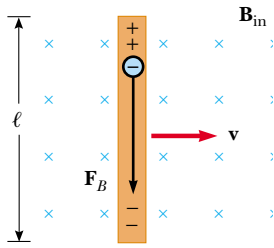

**Figure 31.7**

## 31.2 MOTIONAL EMF

In Examples 31.1 and 31.2, we considered cases in which an emf is induced in a stationary circuit placed in a magnetic field when the field changes with time. In this section we describe what is called **motional emf**, which is the emf induced in a conductor moving through a constant magnetic field.

The straight conductor of length  $\ell$  shown in Figure 31.8 is moving through a uniform magnetic field directed into the page. For simplicity, we assume that the conductor is moving in a direction perpendicular to the field with constant veloc-



**Figure 31.8** A straight electrical conductor of length  $\ell$  moving with a velocity  $\mathbf{v}$  through a uniform magnetic field  $\mathbf{B}$  directed perpendicular to  $\mathbf{v}$ . A potential difference  $\Delta V = B\ell v$  is maintained between the ends of the conductor.

ity under the influence of some external agent. The electrons in the conductor experience a force  $\mathbf{F}_B = q\mathbf{v} \times \mathbf{B}$  that is directed along the length  $\ell$ , perpendicular to both  $\mathbf{v}$  and  $\mathbf{B}$  (Eq. 29.1). Under the influence of this force, the electrons move to the lower end of the conductor and accumulate there, leaving a net positive charge at the upper end. As a result of this charge separation, an electric field is produced inside the conductor. The charges accumulate at both ends until the downward magnetic force  $qvB$  is balanced by the upward electric force  $qE$ . At this point, electrons stop moving. The condition for equilibrium requires that

$$qE = qvB \quad \text{or} \quad E = vB$$

The electric field produced in the conductor (once the electrons stop moving and  $E$  is constant) is related to the potential difference across the ends of the conductor according to the relationship  $\Delta V = E\ell$  (Eq. 25.6). Thus,

$$\Delta V = E\ell = B\ell v \quad (31.4)$$

where the upper end is at a higher electric potential than the lower end. Thus, **a potential difference is maintained between the ends of the conductor as long as the conductor continues to move through the uniform magnetic field.** If the direction of the motion is reversed, the polarity of the potential difference also is reversed.

A more interesting situation occurs when the moving conductor is part of a closed conducting path. This situation is particularly useful for illustrating how a changing magnetic flux causes an induced current in a closed circuit. Consider a circuit consisting of a conducting bar of length  $\ell$  sliding along two fixed parallel conducting rails, as shown in Figure 31.9a.

For simplicity, we assume that the bar has zero resistance and that the stationary part of the circuit has a resistance  $R$ . A uniform and constant magnetic field  $\mathbf{B}$  is applied perpendicular to the plane of the circuit. As the bar is pulled to the right with a velocity  $\mathbf{v}$ , under the influence of an applied force  $\mathbf{F}_{\text{app}}$ , free charges in the bar experience a magnetic force directed along the length of the bar. This force sets up an induced current because the charges are free to move in the closed conducting path. In this case, the rate of change of magnetic flux through the loop and the corresponding induced motional emf across the moving bar are proportional to the change in area of the loop. As we shall see, if the bar is pulled to the right with a constant velocity, the work done by the applied force appears as internal energy in the resistor  $R$  (see Section 27.6).

Because the area enclosed by the circuit at any instant is  $\ell x$ , where  $x$  is the width of the circuit at any instant, the magnetic flux through that area is

$$\Phi_B = B\ell x$$

Using Faraday's law, and noting that  $x$  changes with time at a rate  $dx/dt = v$ , we find that the induced motional emf is

$$\mathcal{E} = -\frac{d\Phi_B}{dt} = -\frac{d}{dt}(B\ell x) = -B\ell \frac{dx}{dt}$$

Motional emf

$$\mathcal{E} = -B\ell v \quad (31.5)$$

Because the resistance of the circuit is  $R$ , the magnitude of the induced current is

$$I = \frac{|\mathcal{E}|}{R} = \frac{B\ell v}{R} \quad (31.6)$$

The equivalent circuit diagram for this example is shown in Figure 31.9b.



Let us examine the system using energy considerations. Because no battery is in the circuit, we might wonder about the origin of the induced current and the electrical energy in the system. We can understand the source of this current and energy by noting that the applied force does work on the conducting bar, thereby moving charges through a magnetic field. Their movement through the field causes the charges to move along the bar with some average drift velocity, and hence a current is established. Because energy must be conserved, the work done by the applied force on the bar during some time interval must equal the electrical energy supplied by the induced emf during that same interval. Furthermore, if the bar moves with constant speed, the work done on it must equal the energy delivered to the resistor during this time interval.

As it moves through the uniform magnetic field  $\mathbf{B}$ , the bar experiences a magnetic force  $\mathbf{F}_B$  of magnitude  $I\ell B$  (see Section 29.2). The direction of this force is opposite the motion of the bar, to the left in Figure 31.9a. Because the bar moves with constant velocity, the applied force must be equal in magnitude and opposite in direction to the magnetic force, or to the right in Figure 31.9a. (If  $\mathbf{F}_B$  acted in the direction of motion, it would cause the bar to accelerate. Such a situation would violate the principle of conservation of energy.) Using Equation 31.6 and the fact that  $F_{\text{app}} = I\ell B$ , we find that the power delivered by the applied force is

$$\mathcal{P} = F_{\text{app}}v = (I\ell B)v = \frac{B^2\ell^2v^2}{R} = \frac{\mathcal{E}^2}{R} \quad (31.7)$$

From Equation 27.23, we see that this power is equal to the rate at which energy is delivered to the resistor  $I^2R$ , as we would expect. It is also equal to the power  $I\mathcal{E}$  supplied by the motional emf. This example is a clear demonstration of the conversion of mechanical energy first to electrical energy and finally to internal energy in the resistor.

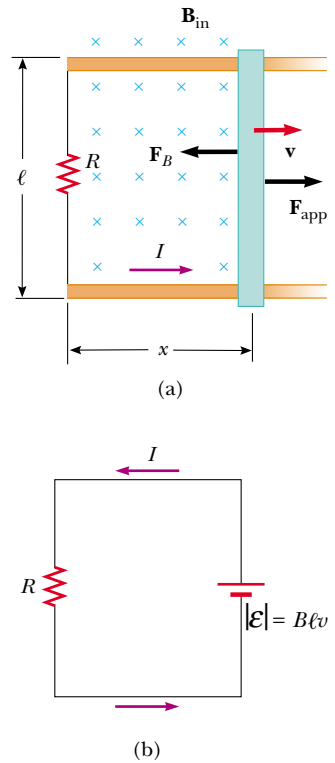

**Figure 31.9** (a) A conducting bar sliding with a velocity  $\mathbf{v}$  along two conducting rails under the action of an applied force  $\mathbf{F}_{\text{app}}$ . The magnetic force  $\mathbf{F}_B$  opposes the motion, and a counterclockwise current  $I$  is induced in the loop. (b) The equivalent circuit diagram for the setup shown in part (a).

### Quick Quiz 31.2

As an airplane flies from Los Angeles to Seattle, it passes through the Earth's magnetic field. As a result, a motional emf is developed between the wingtips. Which wingtip is positively charged?

### EXAMPLE 31.4 Motional emf Induced in a Rotating Bar

A conducting bar of length  $\ell$  rotates with a constant angular speed  $\omega$  about a pivot at one end. A uniform magnetic field  $\mathbf{B}$  is directed perpendicular to the plane of rotation, as shown in Figure 31.10. Find the motional emf induced between the ends of the bar.

**Solution** Consider a segment of the bar of length  $dr$  having a velocity  $\mathbf{v}$ . According to Equation 31.5, the magnitude of the emf induced in this segment is

$$d\mathcal{E} = Bv dr$$

Because every segment of the bar is moving perpendicular to  $\mathbf{B}$ , an emf  $d\mathcal{E}$  of the same form is generated across each. Summing the emfs induced across all segments, which are in series, gives the total emf between the ends of

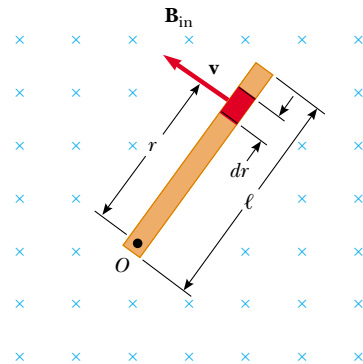

**Figure 31.10** A conducting bar rotating around a pivot at one end in a uniform magnetic field that is perpendicular to the plane of rotation. A motional emf is induced across the ends of the bar.

the bar:

$$\mathcal{E} = \int Bv \, dr$$

To integrate this expression, we must note that the linear speed of an element is related to the angular speed  $\omega$

through the relationship  $v = r\omega$ . Therefore, because  $B$  and  $\omega$  are constants, we find that

$$\mathcal{E} = B \int_0^\ell v \, dr = B\omega \int_0^\ell r \, dr = \frac{1}{2}B\omega\ell^2$$

### EXAMPLE 31.5 Magnetic Force Acting on a Sliding Bar

The conducting bar illustrated in Figure 31.11, of mass  $m$  and length  $\ell$ , moves on two frictionless parallel rails in the presence of a uniform magnetic field directed into the page. The bar is given an initial velocity  $\mathbf{v}_i$  to the right and is released at  $t = 0$ . Find the velocity of the bar as a function of time.

**Solution** The induced current is counterclockwise, and the magnetic force is  $F_B = -I\ell B$ , where the negative sign denotes that the force is to the left and retards the motion. This is the only horizontal force acting on the bar, and hence Newton's second law applied to motion in the horizontal direction gives

$$F_x = ma = m \frac{dv}{dt} = -I\ell B$$

From Equation 31.6, we know that  $I = B\ell v/R$ , and so we can write this expression as

$$m \frac{dv}{dt} = -\frac{B^2\ell^2}{R} v$$

$$\frac{dv}{v} = -\left(\frac{B^2\ell^2}{mR}\right) dt$$

Integrating this equation using the initial condition that  $v = v_i$  at  $t = 0$ , we find that

$$\int_{v_i}^v \frac{dv}{v} = -\frac{B^2\ell^2}{mR} \int_0^t dt$$

$$\ln\left(\frac{v}{v_i}\right) = -\left(\frac{B^2\ell^2}{mR}\right)t = -\frac{t}{\tau}$$

where the constant  $\tau = mR/B^2\ell^2$ . From this result, we see

that the velocity can be expressed in the exponential form

$$v = v_i e^{-t/\tau}$$

This expression indicates that the velocity of the bar decreases exponentially with time under the action of the magnetic retarding force.

**Exercise** Find expressions for the induced current and the magnitude of the induced emf as functions of time for the bar in this example.

**Answer**  $I = \frac{B\ell v_i}{R} e^{-t/\tau}$ ;  $\mathcal{E} = B\ell v_i e^{-t/\tau}$ . (They both decrease exponentially with time.)

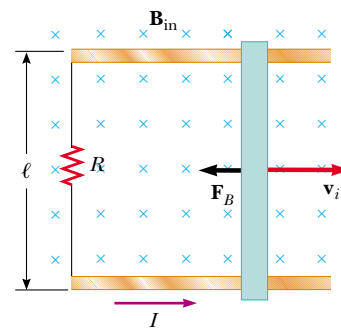

**Figure 31.11** A conducting bar of length  $\ell$  sliding on two fixed conducting rails is given an initial velocity  $\mathbf{v}_i$  to the right.

## 31.3 LENZ'S LAW

 Faraday's law (Eq. 31.1) indicates that the induced emf and the change in flux have opposite algebraic signs. This has a very real physical interpretation that has come to be known as **Lenz's law**<sup>2</sup>:

<sup>2</sup> Developed by the German physicist Heinrich Lenz (1804–1865).

The polarity of the induced emf is such that it tends to produce a current that creates a magnetic flux to oppose the change in magnetic flux through the area enclosed by the current loop.

That is, the induced current tends to keep the original magnetic flux through the circuit from changing. As we shall see, this law is a consequence of the law of conservation of energy.

To understand Lenz's law, let us return to the example of a bar moving to the right on two parallel rails in the presence of a uniform magnetic field that we shall refer to as the *external* magnetic field (Fig. 31.12a). As the bar moves to the right, the magnetic flux through the area enclosed by the circuit increases with time because the area increases. Lenz's law states that the induced current must be directed so that the magnetic flux it produces opposes the change in the external magnetic flux. Because the external magnetic flux is increasing into the page, the induced current, if it is to oppose this change, must produce a flux directed out of the page. Hence, the induced current must be directed counterclockwise when the bar moves to the right. (Use the right-hand rule to verify this direction.) If the bar is moving to the left, as shown in Figure 31.12b, the external magnetic flux through the area enclosed by the loop decreases with time. Because the flux is directed into the page, the direction of the induced current must be clockwise if it is to produce a flux that also is directed into the page. In either case, the induced current tends to maintain the original flux through the area enclosed by the current loop.

Let us examine this situation from the viewpoint of energy considerations. Suppose that the bar is given a slight push to the right. In the preceding analysis, we found that this motion sets up a counterclockwise current in the loop. Let us see what happens if we assume that the current is clockwise, such that the direction of the magnetic force exerted on the bar is to the right. This force would accelerate the rod and increase its velocity. This, in turn, would cause the area enclosed by the loop to increase more rapidly; this would result in an increase in the induced current, which would cause an increase in the force, which would produce an increase in the current, and so on. In effect, the system would acquire energy with no additional input of energy. This is clearly inconsistent with all experience and with the law of conservation of energy. Thus, we are forced to conclude that the current must be counterclockwise.

Let us consider another situation, one in which a bar magnet moves toward a stationary metal loop, as shown in Figure 31.13a. As the magnet moves to the right toward the loop, the external magnetic flux through the loop increases with time. To counteract this increase in flux to the right, the induced current produces a flux to the left, as illustrated in Figure 31.13b; hence, the induced current is in the direction shown. Note that the magnetic field lines associated with the induced current oppose the motion of the magnet. Knowing that like magnetic poles repel each other, we conclude that the left face of the current loop is in essence a north pole and that the right face is a south pole.

If the magnet moves to the left, as shown in Figure 31.13c, its flux through the area enclosed by the loop, which is directed to the right, decreases in time. Now the induced current in the loop is in the direction shown in Figure 31.13d because this current direction produces a magnetic flux in the same direction as the external flux. In this case, the left face of the loop is a south pole and the right face is a north pole.

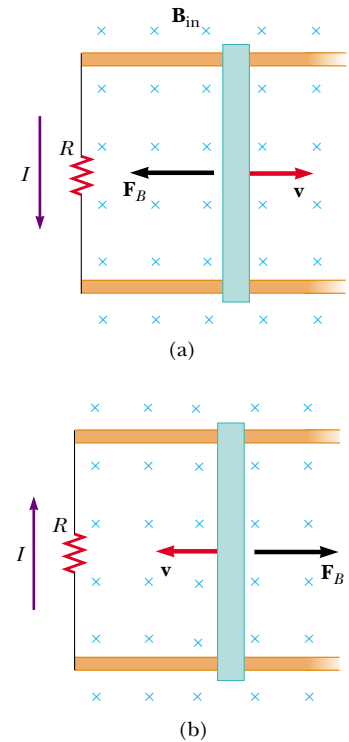

**Figure 31.12** (a) As the conducting bar slides on the two fixed conducting rails, the magnetic flux through the area enclosed by the loop increases in time. By Lenz's law, the induced current must be counterclockwise so as to produce a counteracting magnetic flux directed out of the page. (b) When the bar moves to the left, the induced current must be clockwise. Why?

### QuickLab

This experiment takes steady hands, a dime, and a strong magnet. After verifying that a dime is not attracted to the magnet, carefully balance the coin on its edge. (This won't work with other coins because they require too much force to topple them.) Hold one pole of the magnet within a millimeter of the face of the dime, but don't bump it. Now very rapidly pull the magnet straight back away from the coin. Which way does the dime tip? Does the coin fall the same way most of the time? Explain what is going on in terms of Lenz's law. You may want to refer to Figure 31.13.

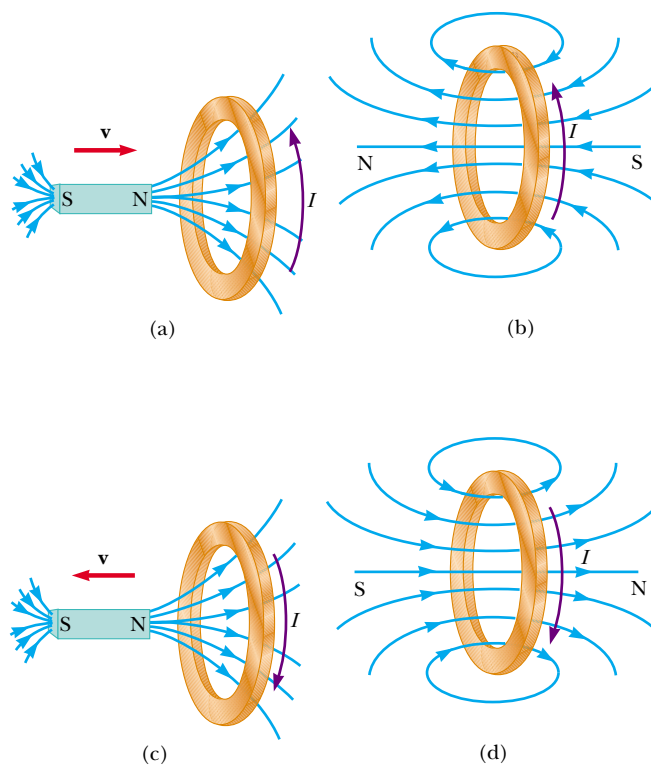

**Figure 31.13** (a) When the magnet is moved toward the stationary conducting loop, a current is induced in the direction shown. (b) This induced current produces its own magnetic flux that is directed to the left and so counteracts the increasing external flux to the right. (c) When the magnet is moved away from the stationary conducting loop, a current is induced in the direction shown. (d) This induced current produces a magnetic flux that is directed to the right and so counteracts the decreasing external flux to the right.

### Quick Quiz 31.3

Figure 31.14 shows a magnet being moved in the vicinity of a solenoid connected to a galvanometer. The south pole of the magnet is the pole nearest the solenoid, and the gal-



**Figure 31.14** When a magnet is moved toward or away from a solenoid attached to a galvanometer, an electric current is induced, indicated by the momentary deflection of the galvanometer needle. (Richard Megna/Fundamental Photographs)

vanometer indicates a clockwise (viewed from above) current in the solenoid. Is the person inserting the magnet or pulling it out?

### CONCEPTUAL EXAMPLE 31.6 Application of Lenz's Law

A metal ring is placed near a solenoid, as shown in Figure 31.15a. Find the direction of the induced current in the ring (a) at the instant the switch in the circuit containing the solenoid is thrown closed, (b) after the switch has been closed for several seconds, and (c) at the instant the switch is thrown open.

**Solution** (a) At the instant the switch is thrown closed, the situation changes from one in which no magnetic flux passes through the ring to one in which flux passes through in the direction shown in Figure 31.15b. To counteract this change in the flux, the current induced in the ring must set up a magnetic field directed from left to right in Figure 31.15b. This requires a current directed as shown.

(b) After the switch has been closed for several seconds, no change in the magnetic flux through the loop occurs; hence, the induced current in the ring is zero.

(c) Opening the switch changes the situation from one in which magnetic flux passes through the ring to one in which there is no magnetic flux. The direction of the induced current is as shown in Figure 31.15c because current in this di-

rection produces a magnetic field that is directed right to left and so counteracts the decrease in the field produced by the solenoid.

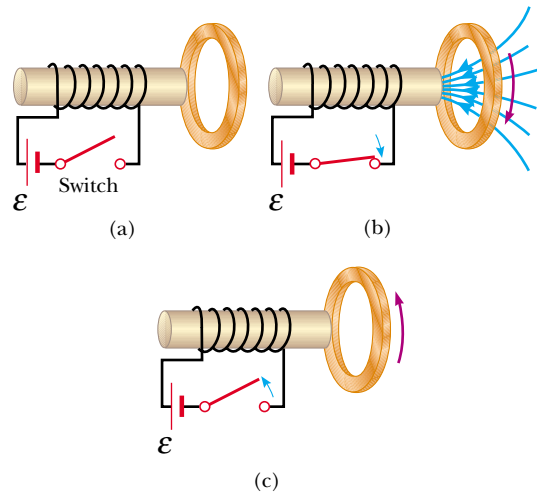

Figure 31.15

### CONCEPTUAL EXAMPLE 31.7 A Loop Moving Through a Magnetic Field

A rectangular metallic loop of dimensions  $\ell$  and  $w$  and resistance  $R$  moves with constant speed  $v$  to the right, as shown in Figure 31.16a, passing through a uniform magnetic field  $\mathbf{B}$  directed into the page and extending a distance  $3w$  along the  $x$  axis. Defining  $x$  as the position of the right side of the loop along the  $x$  axis, plot as functions of  $x$  (a) the magnetic flux through the area enclosed by the loop, (b) the induced motional emf, and (c) the external applied force necessary to counter the magnetic force and keep  $v$  constant.

**Solution** (a) Figure 31.16b shows the flux through the area enclosed by the loop as a function  $x$ . Before the loop enters the field, the flux is zero. As the loop enters the field, the flux increases linearly with position until the left edge of the loop is just inside the field. Finally, the flux through the loop decreases linearly to zero as the loop leaves the field.

(b) Before the loop enters the field, no motional emf is induced in it because no field is present (Fig. 31.16c). As the right side of the loop enters the field, the magnetic flux directed into the page increases. Hence, according to Lenz's law, the induced current is counterclockwise because it must produce a magnetic field directed out of the page. The motional emf  $-B\ell v$  (from Eq. 31.5) arises from the mag-

netic force experienced by charges in the right side of the loop. When the loop is entirely in the field, the change in magnetic flux is zero, and hence the motional emf vanishes. This happens because, once the left side of the loop enters the field, the motional emf induced in it cancels the motional emf present in the right side of the loop. As the right side of the loop leaves the field, the flux inward begins to decrease, a clockwise current is induced, and the induced emf is  $B\ell v$ . As soon as the left side leaves the field, the emf decreases to zero.

(c) The external force that must be applied to the loop to maintain this motion is plotted in Figure 31.16d. Before the loop enters the field, no magnetic force acts on it; hence, the applied force must be zero if  $v$  is constant. When the right side of the loop enters the field, the applied force necessary to maintain constant speed must be equal in magnitude and opposite in direction to the magnetic force exerted on that side:  $F_B = -I\ell B = -B^2\ell^2v/R$ . When the loop is entirely in the field, the flux through the loop is not changing with time. Hence, the net emf induced in the loop is zero, and the current also is zero. Therefore, no external force is needed to maintain the motion. Finally, as the right side leaves the field, the applied force must be equal in magnitude and opposite

in direction to the magnetic force acting on the left side of the loop.

From this analysis, we conclude that power is supplied only when the loop is either entering or leaving the field.

Furthermore, this example shows that the motional emf induced in the loop can be zero even when there is motion through the field! A motional emf is induced only when the magnetic flux through the loop *changes in time*.

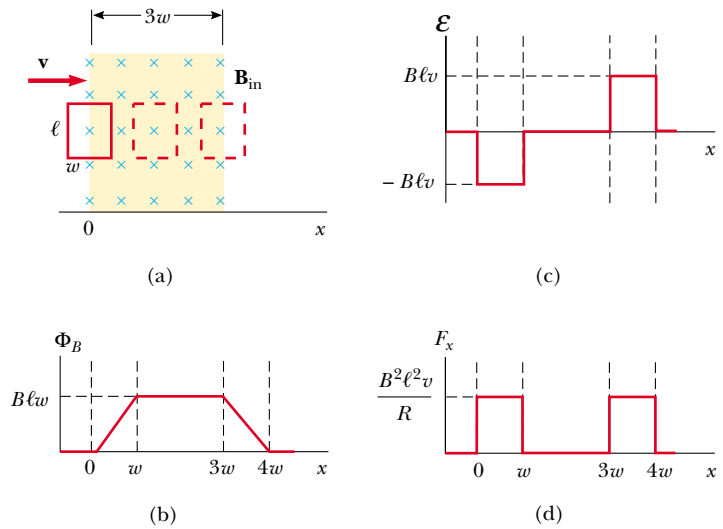

**Figure 31.16** (a) A conducting rectangular loop of width  $w$  and length  $\ell$  moving with a velocity  $\mathbf{v}$  through a uniform magnetic field extending a distance  $3w$ . (b) Magnetic flux through the area enclosed by the loop as a function of loop position. (c) Induced emf as a function of loop position. (d) Applied force required for constant velocity as a function of loop position.

### 31.4 INDUCED EMF AND ELECTRIC FIELDS

**12.8** We have seen that a changing magnetic flux induces an emf and a current in a conducting loop. Therefore, we must conclude that **an electric field is created in the conductor as a result of the changing magnetic flux**. However, this induced electric field has two important properties that distinguish it from the electrostatic field produced by stationary charges: The induced field is nonconservative and can vary in time.

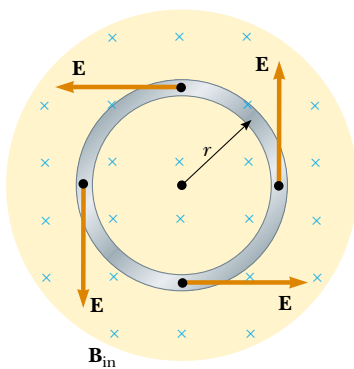

**Figure 31.17** A conducting loop of radius  $r$  in a uniform magnetic field perpendicular to the plane of the loop. If  $\mathbf{B}$  changes in time, an electric field is induced in a direction tangent to the circumference of the loop.

We can illustrate this point by considering a conducting loop of radius  $r$  situated in a uniform magnetic field that is perpendicular to the plane of the loop, as shown in Figure 31.17. If the magnetic field changes with time, then, according to Faraday's law (Eq. 31.1), an emf  $\mathcal{E} = -d\Phi_B/dt$  is induced in the loop. The induction of a current in the loop implies the presence of an induced electric field  $\mathbf{E}$ , which must be tangent to the loop because all points on the loop are equivalent. The work done in moving a test charge  $q$  once around the loop is equal to  $q\mathcal{E}$ . Because the electric force acting on the charge is  $q\mathbf{E}$ , the work done by this force in moving the charge once around the loop is  $qE(2\pi r)$ , where  $2\pi r$  is the circumference of the loop. These two expressions for the work must be equal; therefore, we see that

$$q\mathcal{E} = qE(2\pi r)$$

$$E = \frac{\mathcal{E}}{2\pi r}$$

Using this result, along with Equation 31.1 and the fact that  $\Phi_B = BA = \pi r^2 B$  for a

circular loop, we find that the induced electric field can be expressed as

$$E = -\frac{1}{2\pi r} \frac{d\Phi_B}{dt} = -\frac{r}{2} \frac{dB}{dt} \quad (31.8)$$

If the time variation of the magnetic field is specified, we can easily calculate the induced electric field from Equation 31.8. The negative sign indicates that the induced electric field opposes the change in the magnetic field.

The emf for any closed path can be expressed as the line integral of  $\mathbf{E} \cdot d\mathbf{s}$  over that path:  $\mathcal{E} = \oint \mathbf{E} \cdot d\mathbf{s}$ . In more general cases,  $E$  may not be constant, and the path may not be a circle. Hence, Faraday's law of induction,  $\mathcal{E} = -d\Phi_B/dt$ , can be written in the general form

$$\oint \mathbf{E} \cdot d\mathbf{s} = -\frac{d\Phi_B}{dt} \quad (31.9)$$

Faraday's law in general form

It is important to recognize that **the induced electric field  $\mathbf{E}$  in Equation 31.9 is a nonconservative field that is generated by a changing magnetic field.** The field  $\mathbf{E}$  that satisfies Equation 31.9 cannot possibly be an electrostatic field for the following reason: If the field were electrostatic, and hence conservative, the line integral of  $\mathbf{E} \cdot d\mathbf{s}$  over a closed loop would be zero; this would be in contradiction to Equation 31.9.

### EXAMPLE 31.8 Electric Field Induced by a Changing Magnetic Field in a Solenoid

A long solenoid of radius  $R$  has  $n$  turns of wire per unit length and carries a time-varying current that varies sinusoidally as  $I = I_{\max} \cos \omega t$ , where  $I_{\max}$  is the maximum current and  $\omega$  is the angular frequency of the alternating current source (Fig. 31.18). (a) Determine the magnitude of the induced electric field outside the solenoid, a distance  $r > R$  from its long central axis.

**Solution** First let us consider an external point and take the path for our line integral to be a circle of radius  $r$  centered on the solenoid, as illustrated in Figure 31.18. By sym-

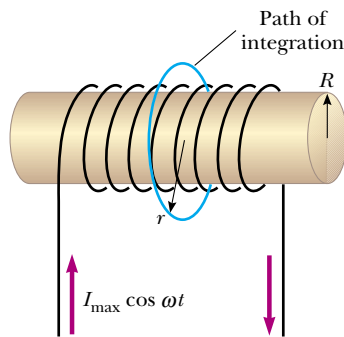

**Figure 31.18** A long solenoid carrying a time-varying current given by  $I = I_0 \cos \omega t$ . An electric field is induced both inside and outside the solenoid.

metry we see that the magnitude of  $\mathbf{E}$  is constant on this path and that  $\mathbf{E}$  is tangent to it. The magnetic flux through the area enclosed by this path is  $BA = B\pi R^2$ ; hence, Equation 31.9 gives

$$\begin{aligned} \oint \mathbf{E} \cdot d\mathbf{s} &= -\frac{d}{dt} (B\pi R^2) = -\pi R^2 \frac{dB}{dt} \\ (1) \quad \oint \mathbf{E} \cdot d\mathbf{s} &= E(2\pi r) = -\pi R^2 \frac{dB}{dt} \end{aligned}$$

The magnetic field inside a long solenoid is given by Equation 30.17,  $B = \mu_0 nI$ . When we substitute  $I = I_{\max} \cos \omega t$  into this equation and then substitute the result into Equation (1), we find that

$$E(2\pi r) = -\pi R^2 \mu_0 n I_{\max} \frac{d}{dt} (\cos \omega t) = \pi R^2 \mu_0 n I_{\max} \omega \sin \omega t$$

$$(2) \quad E = \frac{\mu_0 n I_{\max} \omega R^2}{2r} \sin \omega t \quad (\text{for } r > R)$$

Hence, the electric field varies sinusoidally with time and its amplitude falls off as  $1/r$  outside the solenoid.

(b) What is the magnitude of the induced electric field inside the solenoid, a distance  $r$  from its axis?

**Solution** For an interior point ( $r < R$ ), the flux threading an integration loop is given by  $B\pi r^2$ . Using the same proce-

As in part (a), we find that

$$E(2\pi r) = -\pi r^2 \frac{dB}{dt} = \pi r^2 \mu_0 n I_{\max} \omega \sin \omega t$$

$$(3) \quad E = \frac{\mu_0 n I_{\max} \omega}{2} r \sin \omega t \quad (\text{for } r < R)$$

This shows that the amplitude of the electric field induced inside the solenoid by the changing magnetic flux through the solenoid increases linearly with  $r$  and varies sinusoidally with time.

**Exercise** Show that Equations (2) and (3) for the exterior and interior regions of the solenoid match at the boundary,  $r = R$ .

**Exercise** Would the electric field be different if the solenoid had an iron core?

**Answer** Yes, it could be much stronger because the maximum magnetic field (and thus the change in flux) through the solenoid could be thousands of times larger. (See Example 30.10.)

### Optional Section

## 31.5 GENERATORS AND MOTORS



Turbines turn generators at a hydroelectric power plant. (Luis Casaneda/The Image Bank)

Electric generators are used to produce electrical energy. To understand how they work, let us consider the **alternating current (ac) generator**, a device that converts mechanical energy to electrical energy. In its simplest form, it consists of a loop of wire rotated by some external means in a magnetic field (Fig. 31.19a).

In commercial power plants, the energy required to rotate the loop can be derived from a variety of sources. For example, in a hydroelectric plant, falling water directed against the blades of a turbine produces the rotary motion; in a coal-fired plant, the energy released by burning coal is used to convert water to steam, and this steam is directed against the turbine blades. As a loop rotates in a magnetic field, the magnetic flux through the area enclosed by the loop changes with time; this induces an emf and a current in the loop according to Faraday's law. The ends of the loop are connected to slip rings that rotate with the loop. Connections from these slip rings, which act as output terminals of the generator, to the external circuit are made by stationary brushes in contact with the slip rings.

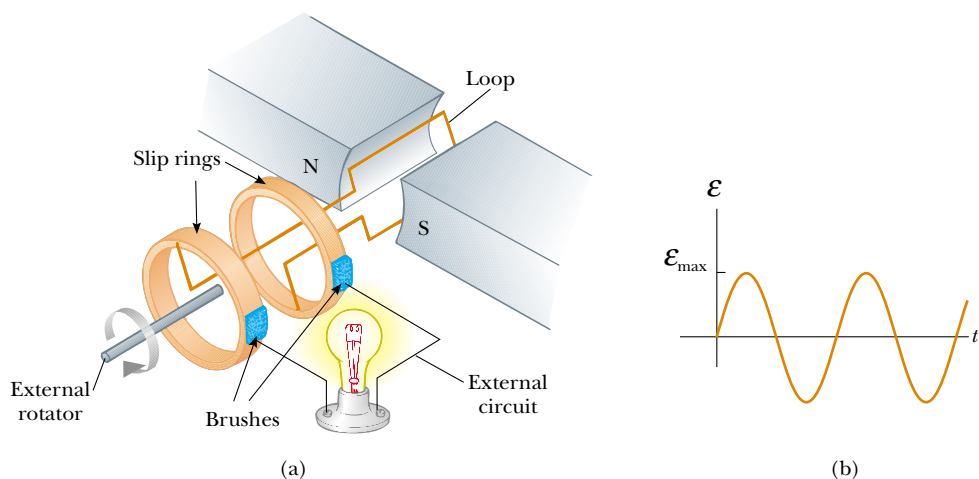

**Figure 31.19** (a) Schematic diagram of an ac generator. An emf is induced in a loop that rotates in a magnetic field. (b) The alternating emf induced in the loop plotted as a function of time.



Suppose that, instead of a single turn, the loop has  $N$  turns (a more practical situation), all of the same area  $A$ , and rotates in a magnetic field with a constant angular speed  $\omega$ . If  $\theta$  is the angle between the magnetic field and the normal to the plane of the loop, as shown in Figure 31.20, then the magnetic flux through the loop at any time  $t$  is

$$\Phi_B = BA \cos \theta = BA \cos \omega t$$

where we have used the relationship  $\theta = \omega t$  between angular displacement and angular speed (see Eq. 10.3). (We have set the clock so that  $t = 0$  when  $\theta = 0$ .) Hence, the induced emf in the coil is

$$\mathcal{E} = -N \frac{d\Phi_B}{dt} = -NAB \frac{d}{dt} (\cos \omega t) = NAB\omega \sin \omega t \quad (31.10)$$

This result shows that the emf varies sinusoidally with time, as was plotted in Figure 31.19b. From Equation 31.10 we see that the maximum emf has the value

$$\mathcal{E}_{\max} = NAB\omega \quad (31.11)$$

which occurs when  $\omega t = 90^\circ$  or  $270^\circ$ . In other words,  $\mathcal{E} = \mathcal{E}_{\max}$  when the magnetic field is in the plane of the coil and the time rate of change of flux is a maximum. Furthermore, the emf is zero when  $\omega t = 0$  or  $180^\circ$ , that is, when  $\mathbf{B}$  is perpendicular to the plane of the coil and the time rate of change of flux is zero.

The frequency for commercial generators in the United States and Canada is 60 Hz, whereas in some European countries it is 50 Hz. (Recall that  $\omega = 2\pi f$ , where  $f$  is the frequency in hertz.)

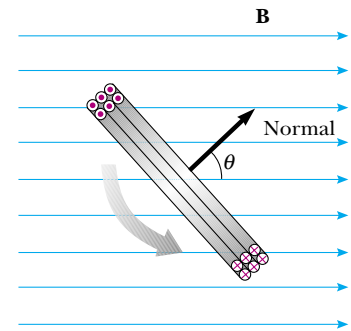

**Figure 31.20** A loop enclosing an area  $A$  and containing  $N$  turns, rotating with constant angular speed  $\omega$  in a magnetic field. The emf induced in the loop varies sinusoidally in time.

### EXAMPLE 31.9 emf Induced in a Generator

An ac generator consists of 8 turns of wire, each of area  $A = 0.0900 \text{ m}^2$ , and the total resistance of the wire is  $12.0 \Omega$ . The loop rotates in a  $0.500\text{-T}$  magnetic field at a constant frequency of  $60.0 \text{ Hz}$ . (a) Find the maximum induced emf.

**Solution** First, we note that  $\omega = 2\pi f = 2\pi(60.0 \text{ Hz}) = 377 \text{ s}^{-1}$ . Thus, Equation 31.11 gives

$$\mathcal{E}_{\max} = NAB\omega = 8(0.0900 \text{ m}^2)(0.500 \text{ T})(377 \text{ s}^{-1}) = 136 \text{ V}$$

(b) What is the maximum induced current when the output terminals are connected to a low-resistance conductor?

**Solution** From Equation 27.8 and the results to part (a), we have

$$I_{\max} = \frac{\mathcal{E}_{\max}}{R} = \frac{136 \text{ V}}{12.0 \Omega} = 11.3 \text{ A}$$

**Exercise** Determine how the induced emf and induced current vary with time.

**Answer**  $\mathcal{E} = \mathcal{E}_{\max} \sin \omega t = (136 \text{ V}) \sin 377t$ ;  
 $I = I_{\max} \sin \omega t = (11.3 \text{ A}) \sin 377t$ .

The **direct current** (dc) **generator** is illustrated in Figure 31.21a. Such generators are used, for instance, in older cars to charge the storage batteries used. The components are essentially the same as those of the ac generator except that the contacts to the rotating loop are made using a split ring called a *commutator*.

In this configuration, the output voltage always has the same polarity and pulsates with time, as shown in Figure 31.21b. We can understand the reason for this by noting that the contacts to the split ring reverse their roles every half cycle. At the same time, the polarity of the induced emf reverses; hence, the polarity of the

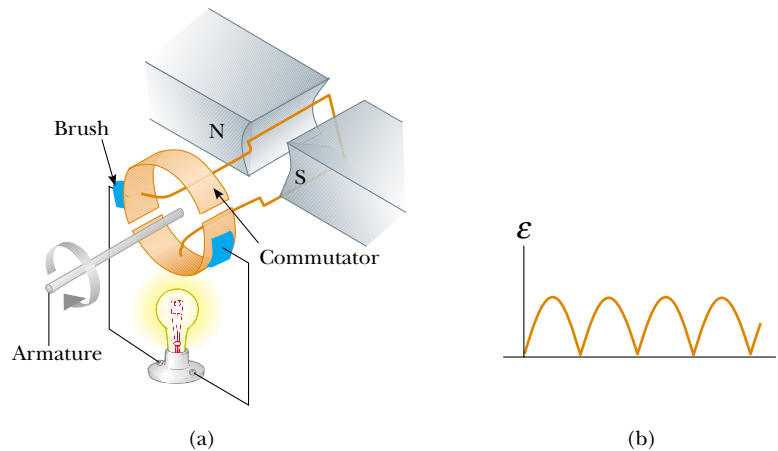

**Figure 31.21** (a) Schematic diagram of a dc generator. (b) The magnitude of the emf varies in time but the polarity never changes.

split ring (which is the same as the polarity of the output voltage) remains the same.

A pulsating dc current is not suitable for most applications. To obtain a more steady dc current, commercial dc generators use many coils and commutators distributed so that the sinusoidal pulses from the various coils are out of phase. When these pulses are superimposed, the dc output is almost free of fluctuations.

**Motors** are devices that convert electrical energy to mechanical energy. Essentially, a motor is a generator operating in reverse. Instead of generating a current by rotating a loop, a current is supplied to the loop by a battery, and the torque acting on the current-carrying loop causes it to rotate.

Useful mechanical work can be done by attaching the rotating armature to some external device. However, as the loop rotates in a magnetic field, the changing magnetic flux induces an emf in the loop; this induced emf always acts to reduce the current in the loop. If this were not the case, Lenz's law would be violated. The back emf increases in magnitude as the rotational speed of the armature increases. (The phrase *back emf* is used to indicate an emf that tends to reduce the supplied current.) Because the voltage available to supply current equals the difference between the supply voltage and the back emf, the current in the rotating coil is limited by the back emf.

When a motor is turned on, there is initially no back emf; thus, the current is very large because it is limited only by the resistance of the coils. As the coils begin to rotate, the induced back emf opposes the applied voltage, and the current in the coils is reduced. If the mechanical load increases, the motor slows down; this causes the back emf to decrease. This reduction in the back emf increases the current in the coils and therefore also increases the power needed from the external voltage source. For this reason, the power requirements for starting a motor and for running it are greater for heavy loads than for light ones. If the motor is allowed to run under no mechanical load, the back emf reduces the current to a value just large enough to overcome energy losses due to internal energy and friction. If a very heavy load jams the motor so that it cannot rotate, the lack of a back emf can lead to dangerously high current in the motor's wire. If the problem is not corrected, a fire could result.

**EXAMPLE 31.10** The Induced Current in a Motor

Assume that a motor in which the coils have a total resistance of  $10\ \Omega$  is supplied by a voltage of  $120\ \text{V}$ . When the motor is running at its maximum speed, the back emf is  $70\ \text{V}$ . Find the current in the coils (a) when the motor is turned on and (b) when it has reached maximum speed.

**Solution** (a) When the motor is turned on, the back emf is zero (because the coils are motionless). Thus, the current in the coils is a maximum and equal to

$$I = \frac{\mathcal{E}}{R} = \frac{120\ \text{V}}{10\ \Omega} = 12\ \text{A}$$

(b) At the maximum speed, the back emf has its maximum value. Thus, the effective supply voltage is that of the external source minus the back emf. Hence, the current is reduced to

$$I = \frac{\mathcal{E} - \mathcal{E}_{\text{back}}}{R} = \frac{120\ \text{V} - 70\ \text{V}}{10\ \Omega} = \frac{50\ \text{V}}{10\ \Omega} = 5.0\ \text{A}$$

**Exercise** If the current in the motor is  $8.0\ \text{A}$  at some instant, what is the back emf at this time?

**Answer**  $40\ \text{V}$ .

*Optional Section***31.6** EDDY CURRENTS

As we have seen, an emf and a current are induced in a circuit by a changing magnetic flux. In the same manner, circulating currents called **eddy currents** are induced in bulk pieces of metal moving through a magnetic field. This can easily be demonstrated by allowing a flat copper or aluminum plate attached at the end of a rigid bar to swing back and forth through a magnetic field (Fig. 31.22). As the plate enters the field, the changing magnetic flux induces an emf in the plate, which in turn causes the free electrons in the plate to move, producing the swirling eddy currents. According to Lenz's law, the direction of the eddy currents must oppose the change that causes them. For this reason, the eddy currents must produce effective magnetic poles on the plate, which are repelled by the poles of the magnet; this gives rise to a repulsive force that opposes the motion of the plate. (If the opposite were true, the plate would accelerate and its energy would

**QuickLab**

Hang a strong magnet from two strings so that it swings back and forth in a plane. Start it oscillating and determine approximately how much time passes before it stops swinging. Start it oscillating again and quickly bring the flat surface of an aluminum cooking sheet up to within a millimeter of the plane of oscillation, taking care not to touch the magnet. How long does it take the oscillating magnet to stop now?

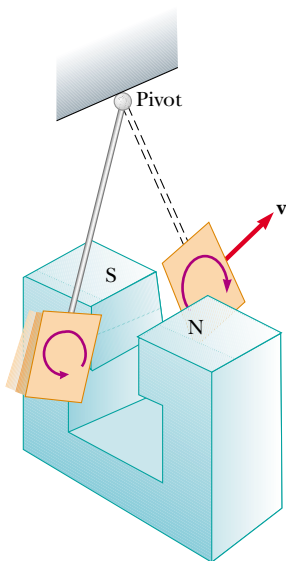

**Figure 31.22** Formation of eddy currents in a conducting plate moving through a magnetic field. As the plate enters or leaves the field, the changing magnetic flux induces an emf, which causes eddy currents in the plate.

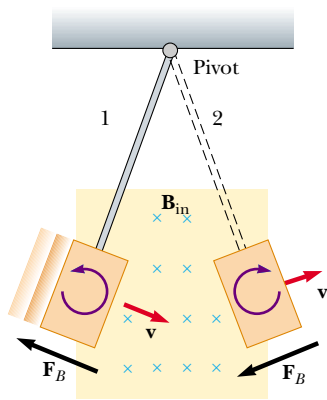

**Figure 31.23** As the conducting plate enters the field (position 1), the eddy currents are counterclockwise. As the plate leaves the field (position 2), the currents are clockwise. In either case, the force on the plate is opposite the velocity, and eventually the plate comes to rest.

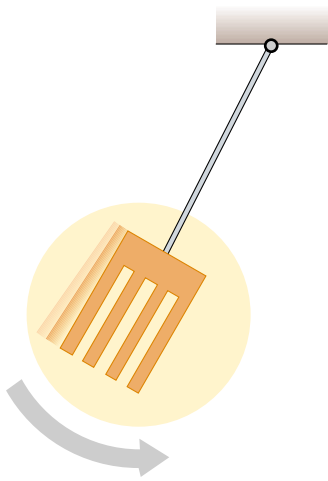

**Figure 31.24** When slots are cut in the conducting plate, the eddy currents are reduced and the plate swings more freely through the magnetic field.

increase after each swing, in violation of the law of conservation of energy.) As you may have noticed while carrying out the QuickLab on page 997, you can “feel” the retarding force by pulling a copper or aluminum sheet through the field of a strong magnet.

As indicated in Figure 31.23, with  $\mathbf{B}$  directed into the page, the induced eddy current is counterclockwise as the swinging plate enters the field at position 1. This is because the external magnetic flux into the page through the plate is increasing, and hence by Lenz's law the induced current must provide a magnetic flux out of the page. The opposite is true as the plate leaves the field at position 2, where the current is clockwise. Because the induced eddy current always produces a magnetic retarding force  $\mathbf{F}_B$  when the plate enters or leaves the field, the swinging plate eventually comes to rest.

If slots are cut in the plate, as shown in Figure 31.24, the eddy currents and the corresponding retarding force are greatly reduced. We can understand this by realizing that the cuts in the plate prevent the formation of any large current loops.

The braking systems on many subway and rapid-transit cars make use of electromagnetic induction and eddy currents. An electromagnet attached to the train is positioned near the steel rails. (An electromagnet is essentially a solenoid with an iron core.) The braking action occurs when a large current is passed through the electromagnet. The relative motion of the magnet and rails induces eddy currents in the rails, and the direction of these currents produces a drag force on the moving train. The loss in mechanical energy of the train is transformed to internal energy in the rails and wheels. Because the eddy currents decrease steadily in magnitude as the train slows down, the braking effect is quite smooth. Eddy-current brakes are also used in some mechanical balances and in various machines. Some power tools use eddy currents to stop rapidly spinning blades once the device is turned off.

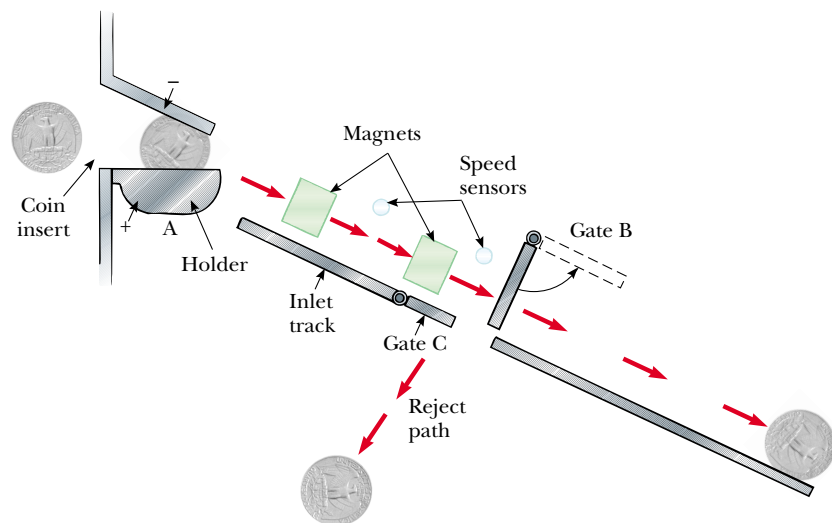

**Figure 31.25** As the coin enters the vending machine, a potential difference is applied across the coin at A, and its resistance is measured. If the resistance is acceptable, the holder drops down, releasing the coin and allowing it to roll along the inlet track. Two magnets induce eddy currents in the coin, and magnetic forces control its speed. If the speed sensors indicate that the coin has the correct speed, gate B swings up to allow the coin to be accepted. If the coin is not moving at the correct speed, gate C opens to allow the coin to follow the reject path.

Eddy currents are often undesirable because they represent a transformation of mechanical energy to internal energy. To reduce this energy loss, moving conducting parts are often laminated—that is, they are built up in thin layers separated by a nonconducting material such as lacquer or a metal oxide. This layered structure increases the resistance of the possible paths of the eddy currents and effectively confines the currents to individual layers. Such a laminated structure is used in transformer cores and motors to minimize eddy currents and thereby increase the efficiency of these devices.

Even a task as simple as buying a candy bar from a vending machine involves eddy currents, as shown in Figure 31.25. After entering the slot, a coin is stopped momentarily while its electrical resistance is checked. If its resistance falls within an acceptable range, the coin is allowed to continue down a ramp and through a magnetic field. As it moves through the field, eddy currents are produced in the coin, and magnetic forces slow it down slightly. How much it is slowed down depends on its metallic composition. Sensors measure the coin's speed after it moves past the magnets, and this speed is compared with expected values. If the coin is legal and passes these tests, a gate is opened and the coin is accepted; otherwise, a second gate moves it into the reject path.

### 31.7 MAXWELL'S WONDERFUL EQUATIONS

 We conclude this chapter by presenting four equations that are regarded as the basis of all electrical and magnetic phenomena. These equations, developed by James Clerk Maxwell, are as fundamental to electromagnetic phenomena as Newton's laws are to mechanical phenomena. In fact, the theory that Maxwell developed was more far-reaching than even he imagined because it turned out to be in agreement with the special theory of relativity, as Einstein showed in 1905.

Maxwell's equations represent the laws of electricity and magnetism that we have already discussed, but they have additional important consequences. In Chapter 34 we shall show that these equations predict the existence of electromagnetic waves (traveling patterns of electric and magnetic fields), which travel with a speed  $c = 1/\sqrt{\mu_0\epsilon_0} = 3.00 \times 10^8$  m/s, the speed of light. Furthermore, the theory shows that such waves are radiated by accelerating charges.

For simplicity, we present **Maxwell's equations** as applied to free space, that is, in the absence of any dielectric or magnetic material. The four equations are

$$\oint_S \mathbf{E} \cdot d\mathbf{A} = \frac{Q}{\epsilon_0} \quad (31.12)$$

Gauss's law

$$\oint_S \mathbf{B} \cdot d\mathbf{A} = 0 \quad (31.13)$$

Gauss's law in magnetism

$$\oint \mathbf{E} \cdot d\mathbf{s} = -\frac{d\Phi_B}{dt} \quad (31.14)$$

Faraday's law

$$\oint \mathbf{B} \cdot d\mathbf{s} = \mu_0 I + \epsilon_0 \mu_0 \frac{d\Phi_E}{dt} \quad (31.15)$$

Ampère–Maxwell law

Equation 31.12 is Gauss's law: **The total electric flux through any closed surface equals the net charge inside that surface divided by  $\epsilon_0$ .** This law relates an electric field to the charge distribution that creates it.

Equation 31.13, which can be considered Gauss's law in magnetism, states that **the net magnetic flux through a closed surface is zero.** That is, the number of magnetic field lines that enter a closed volume must equal the number that leave that volume. This implies that magnetic field lines cannot begin or end at any point. If they did, it would mean that isolated magnetic monopoles existed at those points. The fact that isolated magnetic monopoles have not been observed in nature can be taken as a confirmation of Equation 31.13.

Equation 31.14 is Faraday's law of induction, which describes the creation of an electric field by a changing magnetic flux. This law states that **the emf, which is the line integral of the electric field around any closed path, equals the rate of change of magnetic flux through any surface area bounded by that path.** One consequence of Faraday's law is the current induced in a conducting loop placed in a time-varying magnetic field.

Equation 31.15, usually called the Ampère–Maxwell law, is the generalized form of Ampère's law, which describes the creation of a magnetic field by an electric field and electric currents: **The line integral of the magnetic field around any closed path is the sum of  $\mu_0$  times the net current through that path and  $\epsilon_0\mu_0$  times the rate of change of electric flux through any surface bounded by that path.**

Once the electric and magnetic fields are known at some point in space, the force acting on a particle of charge  $q$  can be calculated from the expression

$$\mathbf{F} = q\mathbf{E} + q\mathbf{v} \times \mathbf{B} \quad (31.16)$$

Lorentz force law

This relationship is called the **Lorentz force law.** (We saw this relationship earlier as Equation 29.16.) Maxwell's equations, together with this force law, completely describe all classical electromagnetic interactions.

It is interesting to note the symmetry of Maxwell's equations. Equations 31.12 and 31.13 are symmetric, apart from the absence of the term for magnetic monopoles in Equation 31.13. Furthermore, Equations 31.14 and 31.15 are symmetric in that the line integrals of  $\mathbf{E}$  and  $\mathbf{B}$  around a closed path are related to the rate of change of magnetic flux and electric flux, respectively. "Maxwell's wonderful equations," as they were called by John R. Pierce,<sup>3</sup> are of fundamental importance not only to electromagnetism but to all of science. Heinrich Hertz once wrote, "One cannot escape the feeling that these mathematical formulas have an independent existence and an intelligence of their own, that they are wiser than we are, wiser even than their discoverers, that we get more out of them than we put into them."

## SUMMARY

**Faraday's law of induction** states that the emf induced in a circuit is directly proportional to the time rate of change of magnetic flux through the circuit:

$$\mathcal{E} = -\frac{d\Phi_B}{dt} \quad (31.1)$$

where  $\Phi_B = \int \mathbf{B} \cdot d\mathbf{A}$  is the magnetic flux.

<sup>3</sup> John R. Pierce, *Electrons and Waves*, New York, Doubleday Science Study Series, 1964. Chapter 6 of this interesting book is recommended as supplemental reading.

When a conducting bar of length  $\ell$  moves at a velocity  $\mathbf{v}$  through a magnetic field  $\mathbf{B}$ , where  $\mathbf{B}$  is perpendicular to the bar and to  $\mathbf{v}$ , the **motional emf** induced in the bar is

$$\mathcal{E} = -B\ell v \quad (31.5)$$

**Lenz's law** states that the induced current and induced emf in a conductor are in such a direction as to oppose the change that produced them.

A general form of **Faraday's law of induction** is

$$\mathcal{E} = \oint \mathbf{E} \cdot d\mathbf{s} = -\frac{d\Phi_B}{dt} \quad (31.9)$$

where  $\mathbf{E}$  is the nonconservative electric field that is produced by the changing magnetic flux.

When used with the Lorentz force law,  $\mathbf{F} = q\mathbf{E} + q\mathbf{v} \times \mathbf{B}$ , **Maxwell's equations** describe all electromagnetic phenomena:

$$\oint_S \mathbf{E} \cdot d\mathbf{A} = \frac{Q}{\epsilon_0} \quad (31.12)$$

$$\oint_S \mathbf{B} \cdot d\mathbf{A} = 0 \quad (31.13)$$

$$\oint \mathbf{E} \cdot d\mathbf{s} = -\frac{d\Phi_B}{dt} \quad (31.14)$$

$$\oint \mathbf{B} \cdot d\mathbf{s} = \mu_0 I + \epsilon_0 \mu_0 \frac{d\Phi_E}{dt} \quad (31.15)$$

The Ampère–Maxwell law (Eq. 31.15) describes how a magnetic field can be produced by both a conduction current and a changing electric flux.

## QUESTIONS

1. A loop of wire is placed in a uniform magnetic field. For what orientation of the loop is the magnetic flux a maximum? For what orientation is the flux zero? Draw pictures of these two situations.
2. As the conducting bar shown in Figure Q31.2 moves to the right, an electric field directed downward is set up in the bar. Explain why the electric field would be upward if the bar were to move to the left.
3. As the bar shown in Figure Q31.2 moves in a direction perpendicular to the field, is an applied force required to keep it moving with constant speed? Explain.
4. The bar shown in Figure Q31.4 moves on rails to the right with a velocity  $\mathbf{v}$ , and the uniform, constant magnetic field is directed out of the page. Why is the induced current clockwise? If the bar were moving to the left, what would be the direction of the induced current?
5. Explain why an applied force is necessary to keep the bar shown in Figure Q31.4 moving with a constant speed.
6. A large circular loop of wire lies in the horizontal plane. A bar magnet is dropped through the loop. If the axis of

the magnet remains horizontal as it falls, describe the emf induced in the loop. How is the situation altered if the axis of the magnet remains vertical as it falls?

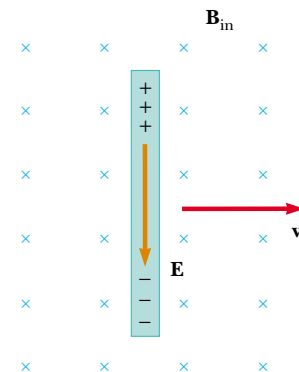

**Figure Q31.2** (Questions 2 and 3).

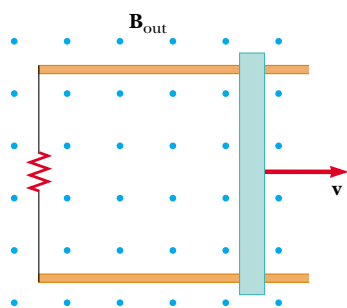

**Figure Q31.4** (Questions 4 and 5).

7. When a small magnet is moved toward a solenoid, an emf is induced in the coil. However, if the magnet is moved around inside a toroid, no emf is induced. Explain.
8. Will dropping a magnet down a long copper tube produce a current in the walls of the tube? Explain.
9. How is electrical energy produced in dams (that is, how is the energy of motion of the water converted to alternating current electricity)?
10. In a beam–balance scale, an aluminum plate is sometimes used to slow the oscillations of the beam near equilibrium. The plate is mounted at the end of the beam and moves between the poles of a small horseshoe magnet attached to the frame. Why are the oscillations strongly damped near equilibrium?
11. What happens when the rotational speed of a generator coil is increased?
12. Could a current be induced in a coil by the rotation of a magnet inside the coil? If so, how?
13. When the switch shown in Figure Q31.13a is closed, a cur-

rent is set up in the coil, and the metal ring springs upward (Fig. Q31.13b). Explain this behavior.

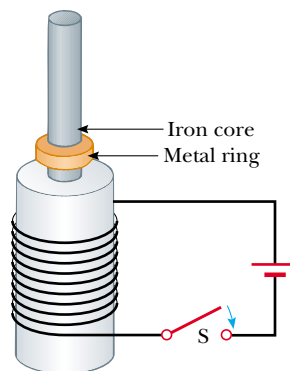

(a)



(b)

**Figure Q31.13** (Questions 13 and 14). (Photo courtesy of Central Scientific Company)

14. Assume that the battery shown in Figure Q31.13a is replaced by an alternating current source and that the switch is held closed. If held down, the metal ring on top of the solenoid becomes hot. Why?
15. Do Maxwell's equations allow for the existence of magnetic monopoles? Explain.

## PROBLEMS

1, 2, 3 = straightforward, intermediate, challenging □ = full solution available in the *Student Solutions Manual and Study Guide*

WEB = solution posted at <http://www.saunderscollege.com/physics/> = Computer useful in solving problem = Interactive Physics

= paired numerical/symbolic problems

### Section 31.1 Faraday's Law of Induction

#### Section 31.2 Motional emf

#### Section 31.3 Lenz's Law

1. A 50-turn rectangular coil of dimensions  $5.00 \text{ cm} \times 10.0 \text{ cm}$  is allowed to fall from a position where  $B = 0$  to a new position where  $B = 0.500 \text{ T}$  and is directed perpendicular to the plane of the coil. Calculate the magnitude of the average emf induced in the coil if the displacement occurs in  $0.250 \text{ s}$ .
2. A flat loop of wire consisting of a single turn of cross-sectional area  $8.00 \text{ cm}^2$  is perpendicular to a magnetic field that increases uniformly in magnitude from  $0.500 \text{ T}$  to  $2.50 \text{ T}$  in  $1.00 \text{ s}$ . What is the resulting induced current if the loop has a resistance of  $2.00 \Omega$ ?

3. A 25-turn circular coil of wire has a diameter of  $1.00 \text{ m}$ . It is placed with its axis along the direction of the Earth's magnetic field of  $50.0 \mu\text{T}$ , and then in  $0.200 \text{ s}$  it is flipped  $180^\circ$ . An average emf of what magnitude is generated in the coil?
4. A rectangular loop of area  $A$  is placed in a region where the magnetic field is perpendicular to the plane of the loop. The magnitude of the field is allowed to vary in time according to the expression  $B = B_{\text{max}}e^{-t/\tau}$ , where  $B_{\text{max}}$  and  $\tau$  are constants. The field has the constant value  $B_{\text{max}}$  for  $t < 0$ . (a) Use Faraday's law to show that the emf induced in the loop is given by

$$\mathcal{E} = (AB_{\text{max}}/\tau)e^{-t/\tau}$$

- (b) Obtain a numerical value for  $\mathcal{E}$  at  $t = 4.00 \text{ s}$  when



$A = 0.160 \text{ m}^2$ ,  $B_{\text{max}} = 0.350 \text{ T}$ , and  $\tau = 2.00 \text{ s}$ . (c) For the values of  $A$ ,  $B_{\text{max}}$ , and  $\tau$  given in part (b), what is the maximum value of  $\mathcal{E}$ ?

- WEB 5.** A strong electromagnet produces a uniform field of  $1.60 \text{ T}$  over a cross-sectional area of  $0.200 \text{ m}^2$ . A coil having 200 turns and a total resistance of  $20.0 \Omega$  is placed around the electromagnet. The current in the electromagnet is then smoothly decreased until it reaches zero in  $20.0 \text{ ms}$ . What is the current induced in the coil?
- 6.** A magnetic field of  $0.200 \text{ T}$  exists within a solenoid of 500 turns and a diameter of  $10.0 \text{ cm}$ . How rapidly (that is, within what period of time) must the field be reduced to zero if the average induced emf within the coil during this time interval is to be  $10.0 \text{ kV}$ ?

- WEB 7.** An aluminum ring with a radius of  $5.00 \text{ cm}$  and a resistance of  $3.00 \times 10^{-4} \Omega$  is placed on top of a long air-core solenoid with 1 000 turns per meter and a radius of  $3.00 \text{ cm}$ , as shown in Figure P31.7. Assume that the axial component of the field produced by the solenoid over the area of the end of the solenoid is one-half as strong as at the center of the solenoid. Assume that the solenoid produces negligible field outside its cross-sectional area. (a) If the current in the solenoid is increasing at a rate of  $270 \text{ A/s}$ , what is the induced current in the ring? (b) At the center of the ring, what is the magnetic field produced by the induced current in the ring? (c) What is the direction of this field?

- 8.** An aluminum ring of radius  $r_1$  and resistance  $R$  is placed on top of a long air-core solenoid with  $n$  turns per meter and smaller radius  $r_2$ , as shown in Figure P31.7. Assume that the axial component of the field produced by the solenoid over the area of the end of the solenoid is one-half as strong as at the center of the solenoid. Assume that the solenoid produces negligible field outside its cross-sectional area. (a) If the current in the solenoid is increasing at a rate of  $\Delta I/\Delta t$ , what is the induced current in the ring? (b) At the center of the ring, what is the magnetic field produced by the induced current in the ring? (c) What is the direction of this field?

- 9.** A loop of wire in the shape of a rectangle of width  $w$  and length  $L$  and a long, straight wire carrying a current  $I$  lie on a tabletop as shown in Figure P31.9. (a) Determine the magnetic flux through the loop due to the current  $I$ . (b) Suppose that the current is changing with time according to  $I = a + bt$ , where  $a$  and  $b$  are constants. Determine the induced emf in the loop if  $b = 10.0 \text{ A/s}$ ,  $h = 1.00 \text{ cm}$ ,  $w = 10.0 \text{ cm}$ , and  $L = 100 \text{ cm}$ . What is the direction of the induced current in the rectangle?

- 10.** A coil of 15 turns and radius  $10.0 \text{ cm}$  surrounds a long solenoid of radius  $2.00 \text{ cm}$  and  $1.00 \times 10^3$  turns per meter (Fig. P31.10). If the current in the solenoid changes as  $I = (5.00 \text{ A}) \sin(120t)$ , find the induced emf in the 15-turn coil as a function of time.

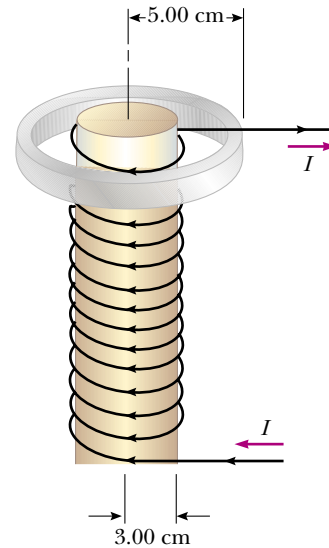

**Figure P31.7** Problems 7 and 8.

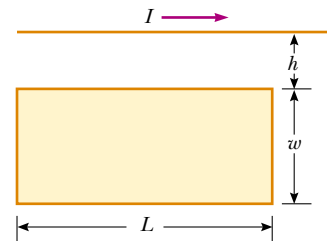

**Figure P31.9** Problems 9 and 73.

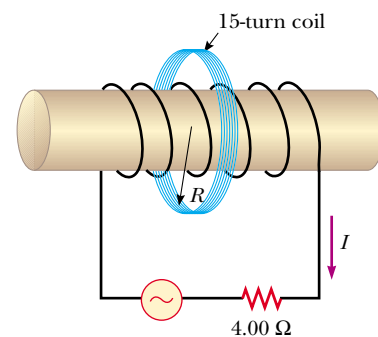

**Figure P31.10**

- 11.** Find the current through section  $PQ$  of length  $a = 65.0 \text{ cm}$  shown in Figure P31.11. The circuit is located in a magnetic field whose magnitude varies with time according to the expression  $B = (1.00 \times 10^{-3} \text{ T/s})t$ . Assume that the resistance per length of the wire is  $0.100 \Omega/\text{m}$ .

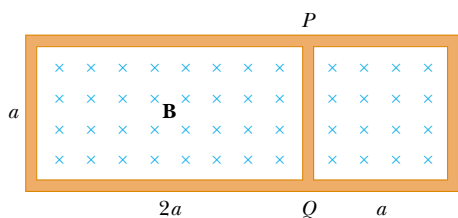

Figure P31.11

12. A 30-turn circular coil of radius 4.00 cm and resistance  $1.00 \Omega$  is placed in a magnetic field directed perpendicular to the plane of the coil. The magnitude of the magnetic field varies in time according to the expression  $B = 0.010 0t + 0.040 0t^2$ , where  $t$  is in seconds and  $B$  is in tesla. Calculate the induced emf in the coil at  $t = 5.00$  s.

13. A long solenoid has 400 turns per meter and carries a current  $I = (30.0 \text{ A})(1 - e^{-1.60t})$ . Inside the solenoid and coaxial with it is a coil that has a radius of 6.00 cm and consists of a total of 250 turns of fine wire (Fig. P31.13). What emf is induced in the coil by the changing current?
14. A long solenoid has  $n$  turns per meter and carries a current  $I = I_{\text{max}}(1 - e^{-at})$ . Inside the solenoid and coaxial with it is a coil that has a radius  $R$  and consists of a total of  $N$  turns of fine wire (see Fig. P31.13). What emf is induced in the coil by the changing current?

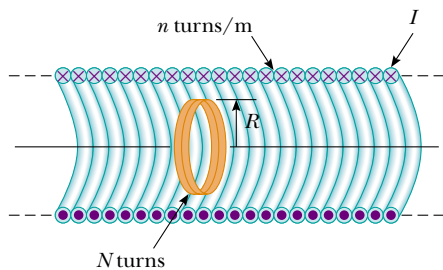

Figure P31.13 Problems 13 and 14.

15. A coil formed by wrapping 50 turns of wire in the shape of a square is positioned in a magnetic field so that the normal to the plane of the coil makes an angle of  $30.0^\circ$  with the direction of the field. When the magnetic field is increased uniformly from  $200 \mu\text{T}$  to  $600 \mu\text{T}$  in 0.400 s, an emf of magnitude 80.0 mV is induced in the coil. What is the total length of the wire?
16. A closed loop of wire is given the shape of a circle with a radius of 0.500 m. It lies in a plane perpendicular to a uniform magnetic field of magnitude 0.400 T. If in 0.100 s the wire loop is reshaped into a square but remains in the same plane, what is the magnitude of the average induced emf in the wire during this time?

17. A toroid having a rectangular cross-section ( $a = 2.00$  cm by  $b = 3.00$  cm) and inner radius  $R = 4.00$  cm consists of 500 turns of wire that carries a current  $I = I_{\text{max}} \sin \omega t$ , with  $I_{\text{max}} = 50.0$  A and a frequency  $f = \omega/2\pi = 60.0$  Hz. A coil that consists of 20 turns of wire links with the toroid, as shown in Figure P31.17. Determine the emf induced in the coil as a function of time.

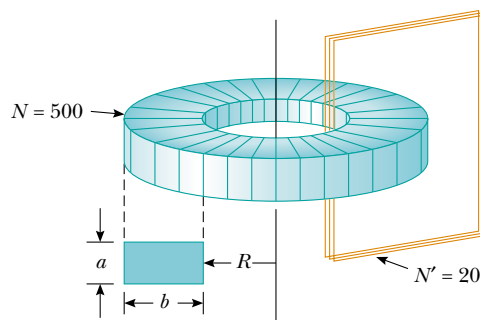

Figure P31.17

18. A single-turn, circular loop of radius  $R$  is coaxial with a long solenoid of radius  $r$  and length  $\ell$  and having  $N$  turns (Fig. P31.18). The variable resistor is changed so that the solenoid current decreases linearly from  $I_1$  to  $I_2$  in an interval  $\Delta t$ . Find the induced emf in the loop.

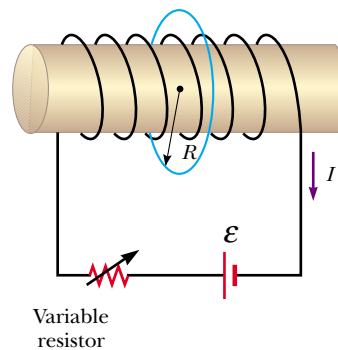

Figure P31.18

19. A circular coil enclosing an area of  $100 \text{ cm}^2$  is made of 200 turns of copper wire, as shown in Figure P31.19. Ini-

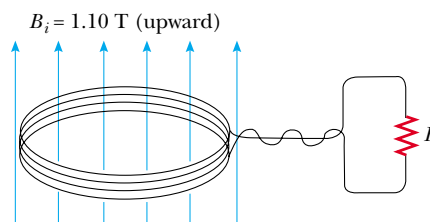

Figure P31.19

tially, a 1.10-T uniform magnetic field points in a perpendicular direction upward through the plane of the coil. The direction of the field then reverses. During the time the field is changing its direction, how much charge flows through the coil if  $R = 5.00 \Omega$ ?

20. Consider the arrangement shown in Figure P31.20. Assume that  $R = 6.00 \Omega$ ,  $\ell = 1.20 \text{ m}$ , and a uniform 2.50-T magnetic field is directed into the page. At what speed should the bar be moved to produce a current of 0.500 A in the resistor?

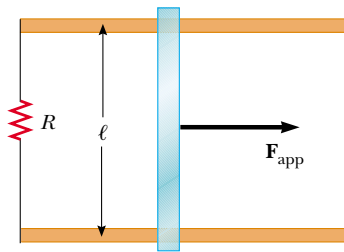

Figure P31.20 Problems 20, 21, and 22.

21. Figure P31.20 shows a top view of a bar that can slide without friction. The resistor is  $6.00 \Omega$  and a 2.50-T magnetic field is directed perpendicularly downward, into the paper. Let  $\ell = 1.20 \text{ m}$ . (a) Calculate the applied force required to move the bar to the right at a constant speed of 2.00 m/s. (b) At what rate is energy delivered to the resistor?
22. A conducting rod of length  $\ell$  moves on two horizontal, frictionless rails, as shown in Figure P31.20. If a constant force of 1.00 N moves the bar at 2.00 m/s through a magnetic field  $\mathbf{B}$  that is directed into the page, (a) what is the current through an  $8.00\text{-}\Omega$  resistor  $R$ ? (b) What is the rate at which energy is delivered to the resistor? (c) What is the mechanical power delivered by the force  $\mathbf{F}_{\text{app}}$ ?
23. A Boeing-747 jet with a wing span of 60.0 m is flying horizontally at a speed of 300 m/s over Phoenix, Arizona, at a location where the Earth's magnetic field is  $50.0 \mu\text{T}$  at  $58.0^\circ$  below the horizontal. What voltage is generated between the wingtips?
24. The square loop in Figure P31.24 is made of wires with total series resistance  $10.0 \Omega$ . It is placed in a uniform

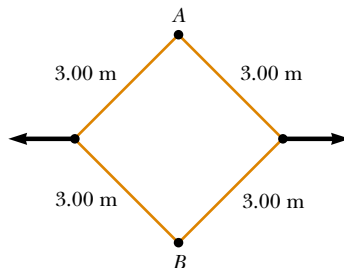

Figure P31.24

0.100-T magnetic field directed perpendicular into the plane of the paper. The loop, which is hinged at each corner, is pulled as shown until the separation between points A and B is 3.00 m. If this process takes 0.100 s, what is the average current generated in the loop? What is the direction of the current?

25. A helicopter has blades with a length of 3.00 m extending outward from a central hub and rotating at 2.00 rev/s. If the vertical component of the Earth's magnetic field is  $50.0 \mu\text{T}$ , what is the emf induced between the blade tip and the center hub?
26. Use Lenz's law to answer the following questions concerning the direction of induced currents: (a) What is the direction of the induced current in resistor  $R$  shown in Figure P31.26a when the bar magnet is moved to the left? (b) What is the direction of the current induced in the resistor  $R$  right after the switch  $S$  in Figure P31.26b is closed? (c) What is the direction of the induced current in  $R$  when the current  $I$  in Figure P31.26c decreases rapidly to zero? (d) A copper bar is moved to the right while its axis is maintained in a direction perpendicular to a magnetic field, as shown in Figure P31.26d. If the top of the bar becomes positive relative to the bottom, what is the direction of the magnetic field?

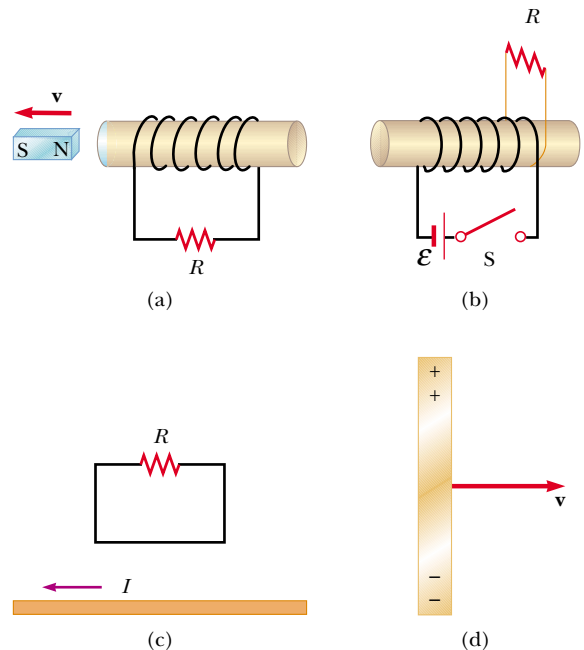

Figure P31.26

27. A rectangular coil with resistance  $R$  has  $N$  turns, each of length  $\ell$  and width  $w$  as shown in Figure P31.27. The coil moves into a uniform magnetic field  $\mathbf{B}$  with a velocity  $\mathbf{v}$ . What are the magnitude and direction of the resultant force on the coil (a) as it enters the magnetic field, (b) as it moves within the field, and (c) as it leaves the field?

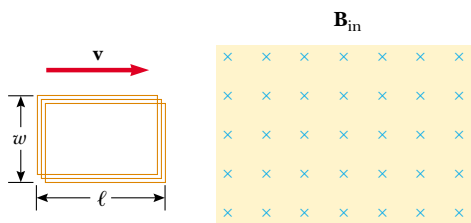

Figure P31.27

28. In 1832 Faraday proposed that the apparatus shown in Figure P31.28 could be used to generate electric current from the water flowing in the Thames River.<sup>4</sup> Two conducting plates of lengths  $a$  and widths  $b$  are placed facing each other on opposite sides of the river, a distance  $w$  apart, and are immersed entirely. The flow velocity of the river is  $\mathbf{v}$  and the vertical component of the Earth's magnetic field is  $B$ . (a) Show that the current in the load resistor  $R$  is

$$I = \frac{abvB}{\rho + abR/w}$$

where  $\rho$  is the electrical resistivity of the water. (b) Calculate the short-circuit current ( $R = 0$ ) if  $a = 100$  m,  $b = 5.00$  m,  $v = 3.00$  m/s,  $B = 50.0$   $\mu$ T, and  $\rho = 100$   $\Omega \cdot$ m.

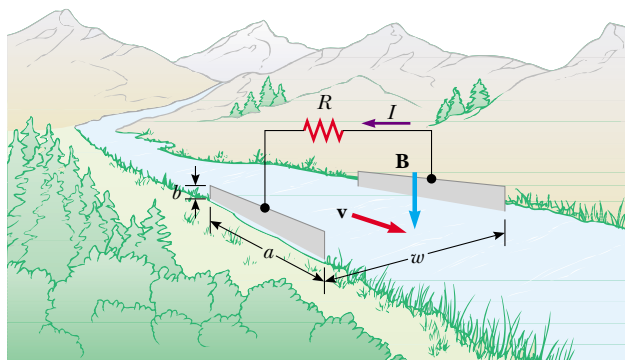

Figure P31.28

29. In Figure P31.29, the bar magnet is moved toward the loop. Is  $V_a - V_b$  positive, negative, or zero? Explain.
30. A metal bar spins at a constant rate in the magnetic field of the Earth as in Figure 31.10. The rotation occurs in a region where the component of the Earth's magnetic field perpendicular to the plane of rotation is  $3.30 \times 10^{-5}$  T. If the bar is 1.00 m in length and its angular speed is  $5.00 \pi$  rad/s, what potential difference is developed between its ends?

<sup>4</sup> The idea for this problem and Figure P31.28 is from Oleg D. Jefimenko, *Electricity and Magnetism: An Introduction to the Theory of Electric and Magnetic Fields*. Star City, WV, Electret Scientific Co., 1989.

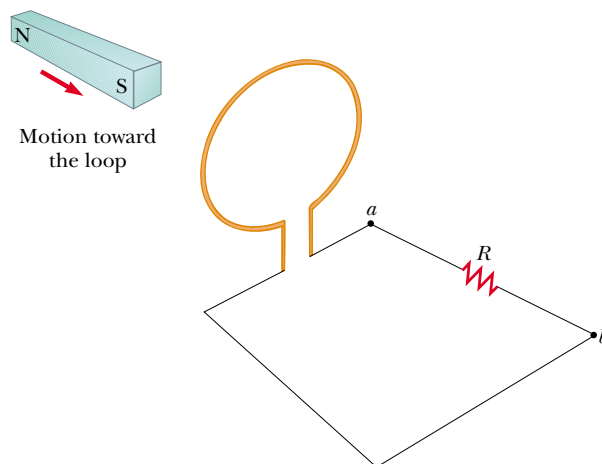

Figure P31.29

31. Two parallel rails with negligible resistance are 10.0 cm apart and are connected by a 5.00- $\Omega$  resistor. The circuit also contains two metal rods having resistances of 10.0  $\Omega$  and 15.0  $\Omega$  sliding along the rails (Fig. P31.31). The rods are pulled away from the resistor at constant speeds 4.00 m/s and 2.00 m/s, respectively. A uniform magnetic field of magnitude 0.010 0 T is applied perpendicular to the plane of the rails. Determine the current in the 5.00- $\Omega$  resistor.

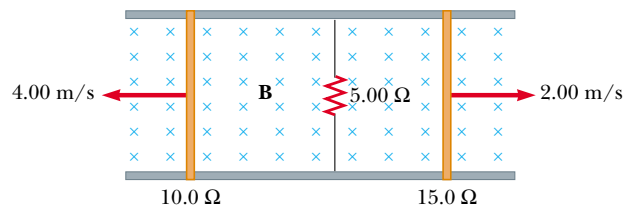

Figure P31.31

**Section 31.4 Induced emf and Electric Fields**

32. For the situation described in Figure P31.32, the magnetic field changes with time according to the expression  $B = (2.00t^3 - 4.00t^2 + 0.800)$  T, and  $r_2 = 2R = 5.00$  cm. (a) Calculate the magnitude and direction of

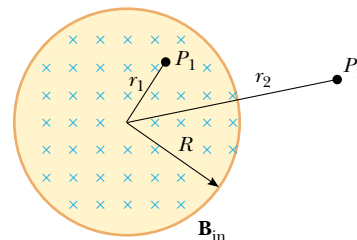

Figure P31.32 Problems 32 and 33.

the force exerted on an electron located at point  $P_2$  when  $t = 2.00$  s. (b) At what time is this force equal to zero?

33. A magnetic field directed into the page changes with time according to  $B = (0.030 \text{ } 0t^2 + 1.40) \text{ T}$ , where  $t$  is in seconds. The field has a circular cross-section of radius  $R = 2.50$  cm (see Fig. P31.32). What are the magnitude and direction of the electric field at point  $P_1$  when  $t = 3.00$  s and  $r_1 = 0.020$  m?
34. A solenoid has a radius of 2.00 cm and 1 000 turns per meter. Over a certain time interval the current varies with time according to the expression  $I = 3e^{0.2t}$ , where  $I$  is in amperes and  $t$  is in seconds. Calculate the electric field 5.00 cm from the axis of the solenoid at  $t = 10.0$  s.
35. A long solenoid with 1 000 turns per meter and radius 2.00 cm carries an oscillating current  $I = (5.00 \text{ A}) \sin(100\pi t)$ . (a) What is the electric field induced at a radius  $r = 1.00$  cm from the axis of the solenoid? (b) What is the direction of this electric field when the current is increasing counterclockwise in the coil?

(Optional)

### Section 31.5 Generators and Motors

36. In a 250-turn automobile alternator, the magnetic flux in each turn is  $\Phi_B = (2.50 \times 10^{-4} \text{ T} \cdot \text{m}^2) \cos(\omega t)$ , where  $\omega$  is the angular speed of the alternator. The alternator is geared to rotate three times for each engine revolution. When the engine is running at an angular speed of 1 000 rev/min, determine (a) the induced emf in the alternator as a function of time and (b) the maximum emf in the alternator.
- WEB 37. A coil of area  $0.100 \text{ m}^2$  is rotating at 60.0 rev/s with the axis of rotation perpendicular to a 0.200-T magnetic field. (a) If there are 1 000 turns on the coil, what is the maximum voltage induced in it? (b) What is the orientation of the coil with respect to the magnetic field when the maximum induced voltage occurs?
38. A square coil ( $20.0 \text{ cm} \times 20.0 \text{ cm}$ ) that consists of 100 turns of wire rotates about a vertical axis at 1 500 rev/min, as indicated in Figure P31.38. The horizontal component of the Earth's magnetic field at the location of the coil is  $2.00 \times 10^{-5} \text{ T}$ . Calculate the maximum emf induced in the coil by this field.

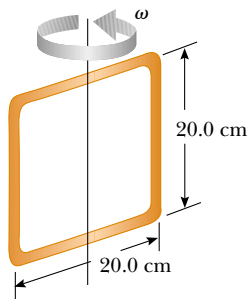

Figure P31.38

39. A long solenoid, with its axis along the  $x$  axis, consists of 200 turns per meter of wire that carries a steady current of 15.0 A. A coil is formed by wrapping 30 turns of thin wire around a circular frame that has a radius of 8.00 cm. The coil is placed inside the solenoid and mounted on an axis that is a diameter of the coil and coincides with the  $y$  axis. The coil is then rotated with an angular speed of  $4.00\pi$  rad/s. (The plane of the coil is in the  $yz$  plane at  $t = 0$ .) Determine the emf developed in the coil as a function of time.
40. A bar magnet is spun at constant angular speed  $\omega$  around an axis, as shown in Figure P31.40. A flat rectangular conducting loop surrounds the magnet, and at  $t = 0$ , the magnet is oriented as shown. Make a qualitative graph of the induced current in the loop as a function of time, plotting counterclockwise currents as positive and clockwise currents as negative.

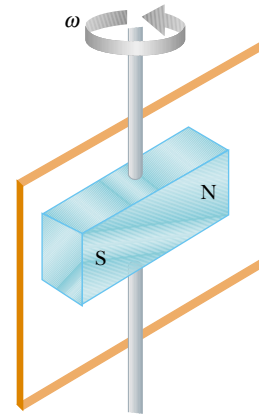

Figure P31.40

41. (a) What is the maximum torque delivered by an electric motor if it has 80 turns of wire wrapped on a rectangular coil of dimensions 2.50 cm by 4.00 cm? Assume that the motor uses 10.0 A of current and that a uniform 0.800-T magnetic field exists within the motor. (b) If the motor rotates at 3 600 rev/min, what is the peak power produced by the motor?
42. A semicircular conductor of radius  $R = 0.250$  m is rotated about the axis  $AC$  at a constant rate of 120 rev/min (Fig. P31.42). A uniform magnetic field in all of the lower half of the figure is directed out of the plane of rotation and has a magnitude of 1.30 T. (a) Calculate the maximum value of the emf induced in the conductor. (b) What is the value of the average induced emf for each complete rotation? (c) How would the answers to parts (a) and (b) change if  $\mathbf{B}$  were allowed to extend a distance  $R$  above the axis of rotation? Sketch the emf versus time (d) when the field is as drawn in Figure P31.42 and (e) when the field is extended as described in part (c).

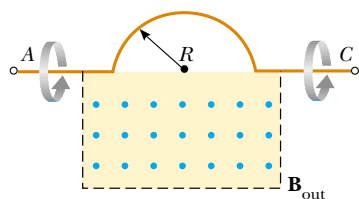

Figure P31.42

43. The rotating loop in an ac generator is a square 10.0 cm on a side. It is rotated at 60.0 Hz in a uniform field of 0.800 T. Calculate (a) the flux through the loop as a function of time, (b) the emf induced in the loop, (c) the current induced in the loop for a loop resistance of 1.00  $\Omega$ , (d) the power in the resistance of the loop, and (e) the torque that must be exerted to rotate the loop.

(Optional)

**Section 31.6 Eddy Currents**

44. A 0.150-kg wire in the shape of a closed rectangle 1.00 m wide and 1.50 m long has a total resistance of 0.750  $\Omega$ . The rectangle is allowed to fall through a magnetic field directed perpendicular to the direction of motion of the rectangle (Fig. P31.44). The rectangle accelerates downward as it approaches a terminal speed of 2.00 m/s, with its top not yet in the region of the field. Calculate the magnitude of  $\mathbf{B}$ .

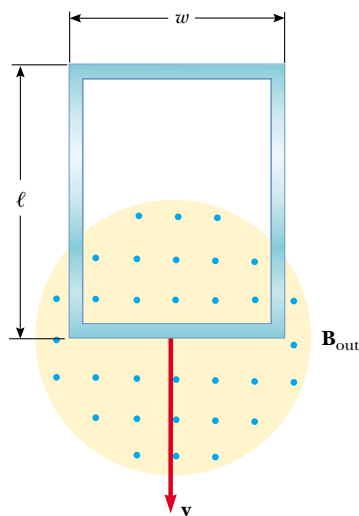

Figure P31.44 Problems 44 and 45.

- WEB** 45. A conducting rectangular loop of mass  $M$ , resistance  $R$ , and dimensions  $w$  by  $\ell$  falls from rest into a magnetic field  $\mathbf{B}$  as in Figure P31.44. The loop approaches termi-

nal speed  $v_t$ . (a) Show that

$$v_t = \frac{MgR}{B^2 w^2}$$

(b) Why is  $v_t$  proportional to  $R$ ? (c) Why is it inversely proportional to  $B^2$ ?

46. Figure P31.46 represents an electromagnetic brake that utilizes eddy currents. An electromagnet hangs from a railroad car near one rail. To stop the car, a large steady current is sent through the coils of the electromagnet. The moving electromagnet induces eddy currents in the rails, whose fields oppose the change in the field of the electromagnet. The magnetic fields of the eddy currents exert force on the current in the electromagnet, thereby slowing the car. The direction of the car's motion and the direction of the current in the electromagnet are shown correctly in the picture. Determine which of the eddy currents shown on the rails is correct. Explain your answer.

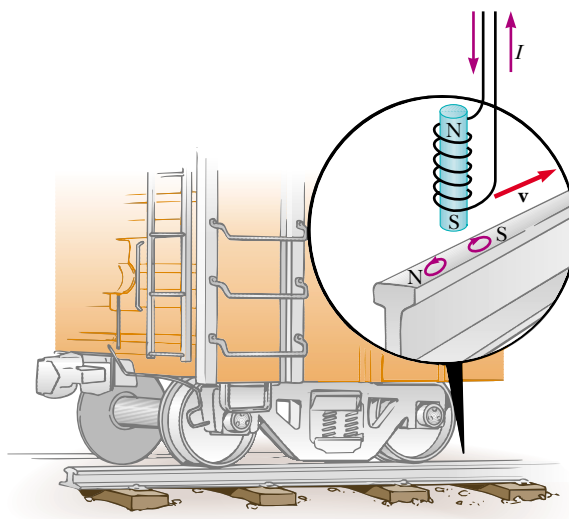

Figure P31.46

**Section 31.7 Maxwell's Wonderful Equations**

47. A proton moves through a uniform electric field  $\mathbf{E} = 50.0\mathbf{j}$  V/m and a uniform magnetic field  $\mathbf{B} = (0.200\mathbf{i} + 0.300\mathbf{j} + 0.400\mathbf{k})$  T. Determine the acceleration of the proton when it has a velocity  $\mathbf{v} = 200\mathbf{i}$  m/s.
48. An electron moves through a uniform electric field  $\mathbf{E} = (2.50\mathbf{i} + 5.00\mathbf{j})$  V/m and a uniform magnetic field  $\mathbf{B} = 0.400\mathbf{k}$  T. Determine the acceleration of the electron when it has a velocity  $\mathbf{v} = 10.0\mathbf{i}$  m/s.

**ADDITIONAL PROBLEMS**

49. A steel guitar string vibrates (see Fig. 31.5). The component of the magnetic field perpendicular to the area of

a pickup coil nearby is given by

$$B = 50.0 \text{ mT} + (3.20 \text{ mT}) \sin(2\pi 523 t/s)$$

The circular pickup coil has 30 turns and radius 2.70 mm. Find the emf induced in the coil as a function of time.

50. Figure P31.50 is a graph of the induced emf versus time for a coil of  $N$  turns rotating with angular velocity  $\omega$  in a uniform magnetic field directed perpendicular to the axis of rotation of the coil. Copy this graph (on a larger scale), and on the same set of axes show the graph of emf versus  $t$  (a) if the number of turns in the coil is doubled, (b) if instead the angular velocity is doubled, and (c) if the angular velocity is doubled while the number of turns in the coil is halved.

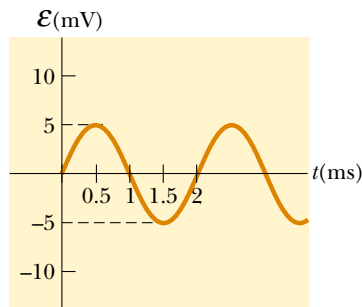

Figure P31.50

51. A technician wearing a brass bracelet enclosing an area of  $0.00500 \text{ m}^2$  places her hand in a solenoid whose magnetic field is  $5.00 \text{ T}$  directed perpendicular to the plane of the bracelet. The electrical resistance around the circumference of the bracelet is  $0.0200 \Omega$ . An unexpected power failure causes the field to drop to  $1.50 \text{ T}$  in a time of  $20.0 \text{ ms}$ . Find (a) the current induced in the bracelet and (b) the power delivered to the resistance of the bracelet. (Note: As this problem implies, you should not wear any metallic objects when working in regions of strong magnetic fields.)
52. Two infinitely long solenoids (seen in cross-section) thread a circuit as shown in Figure P31.52. The magni-

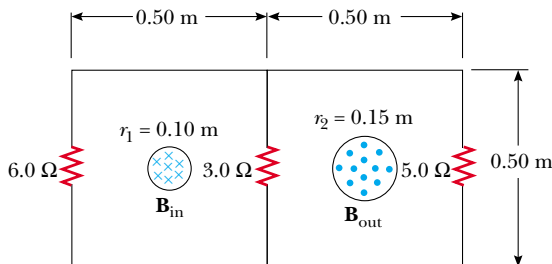

Figure P31.52

tude of  $\mathbf{B}$  inside each is the same and is increasing at the rate of  $100 \text{ T/s}$ . What is the current in each resistor?

53. A conducting rod of length  $\ell = 35.0 \text{ cm}$  is free to slide on two parallel conducting bars, as shown in Figure P31.53. Two resistors  $R_1 = 2.00 \Omega$  and  $R_2 = 5.00 \Omega$  are connected across the ends of the bars to form a loop. A constant magnetic field  $B = 2.50 \text{ T}$  is directed perpendicular into the page. An external agent pulls the rod to the left with a constant speed of  $v = 8.00 \text{ m/s}$ . Find (a) the currents in both resistors, (b) the total power delivered to the resistance of the circuit, and (c) the magnitude of the applied force that is needed to move the rod with this constant velocity.

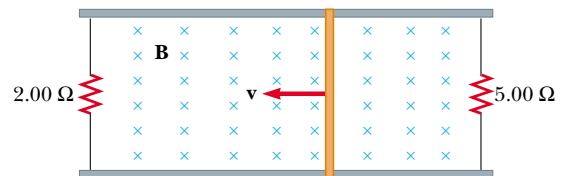

Figure P31.53

54. Suppose you wrap wire onto the core from a roll of cellophane tape to make a coil. Describe how you can use a bar magnet to produce an induced voltage in the coil. What is the order of magnitude of the emf you generate? State the quantities you take as data and their values.
55. A bar of mass  $m$ , length  $d$ , and resistance  $R$  slides without friction on parallel rails, as shown in Figure P31.55. A battery that maintains a constant emf  $\mathcal{E}$  is connected between the rails, and a constant magnetic field  $\mathbf{B}$  is directed perpendicular to the plane of the page. If the bar starts from rest, show that at time  $t$  it moves with a speed

$$v = \frac{\mathcal{E}}{Bd} (1 - e^{-B^2 d^2 t / mR})$$

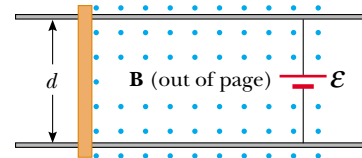

Figure P31.55

56. An automobile has a vertical radio antenna  $1.20 \text{ m}$  long. The automobile travels at  $65.0 \text{ km/h}$  on a horizontal road where the Earth's magnetic field is  $50.0 \mu\text{T}$  directed toward the north and downward at an angle of  $65.0^\circ$  below the horizontal. (a) Specify the direction that the automobile should move to generate the maxi-

imum motional emf in the antenna, with the top of the antenna positive relative to the bottom. (b) Calculate the magnitude of this induced emf.

57. The plane of a square loop of wire with edge length  $a = 0.200$  m is perpendicular to the Earth's magnetic field at a point where  $B = 15.0 \mu\text{T}$ , as shown in Figure P31.57. The total resistance of the loop and the wires connecting it to the galvanometer is  $0.500 \Omega$ . If the loop is suddenly collapsed by horizontal forces as shown, what total charge passes through the galvanometer?

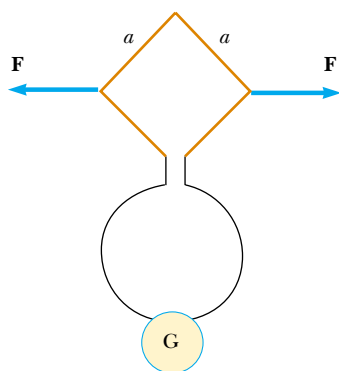

Figure P31.57

58. Magnetic field values are often determined by using a device known as a *search coil*. This technique depends on the measurement of the total charge passing through a coil in a time interval during which the magnetic flux linking the windings changes either because of the motion of the coil or because of a change in the value of  $B$ . (a) Show that as the flux through the coil changes from  $\Phi_1$  to  $\Phi_2$ , the charge transferred through the coil will be given by  $Q = N(\Phi_2 - \Phi_1)/R$ , where  $R$  is the resistance of the coil and associated circuitry (galvanometer) and  $N$  is the number of turns. (b) As a specific example, calculate  $B$  when a 100-turn coil of resistance  $200 \Omega$  and cross-sectional area  $40.0 \text{ cm}^2$  produces the following results. A total charge of  $5.00 \times 10^{-4} \text{ C}$  passes through the coil when it is rotated in a uniform field from a position where the plane of the coil is perpendicular to the field to a position where the coil's plane is parallel to the field.
59. In Figure P31.59, the rolling axle, 1.50 m long, is pushed along horizontal rails at a constant speed  $v = 3.00 \text{ m/s}$ . A resistor  $R = 0.400 \Omega$  is connected to the rails at points  $a$  and  $b$ , directly opposite each other. (The wheels make good electrical contact with the rails, and so the axle, rails, and  $R$  form a closed-loop circuit. The only significant resistance in the circuit is  $R$ .) There is a uniform magnetic field  $B = 0.0800 \text{ T}$  vertically downward. (a) Find the induced current  $I$  in the resistor. (b) What horizontal force  $F$  is required to keep the

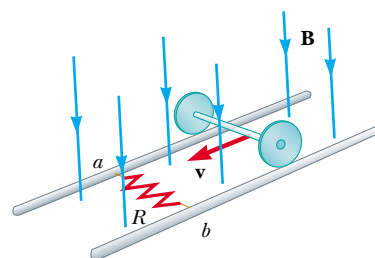

Figure P31.59

- axle rolling at constant speed? (c) Which end of the resistor,  $a$  or  $b$ , is at the higher electric potential? (d) After the axle rolls past the resistor, does the current in  $R$  reverse direction? Explain your answer.
60. A conducting rod moves with a constant velocity  $\mathbf{v}$  perpendicular to a long, straight wire carrying a current  $I$  as shown in Figure P31.60. Show that the magnitude of the emf generated between the ends of the rod is

$$|\mathcal{E}| = \frac{\mu_0 v I}{2\pi r} \ell$$

In this case, note that the emf decreases with increasing  $r$ , as you might expect.

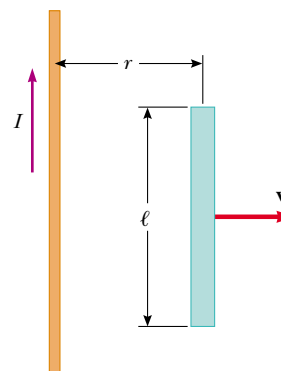

Figure P31.60

61. A circular loop of wire of radius  $r$  is in a uniform magnetic field, with the plane of the loop perpendicular to the direction of the field (Fig. P31.61). The magnetic field varies with time according to  $B(t) = a + bt$ , where  $a$  and  $b$  are constants. (a) Calculate the magnetic flux through the loop at  $t = 0$ . (b) Calculate the emf induced in the loop. (c) If the resistance of the loop is  $R$ , what is the induced current? (d) At what rate is electrical energy being delivered to the resistance of the loop?
62. In Figure P31.62, a uniform magnetic field decreases at a constant rate  $dB/dt = -K$ , where  $K$  is a positive constant. A circular loop of wire of radius  $a$  containing a re-



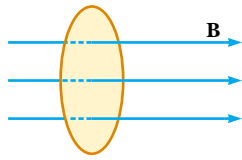

Figure P31.61

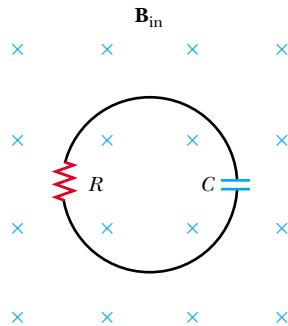

Figure P31.62

distance  $R$  and a capacitance  $C$  is placed with its plane normal to the field. (a) Find the charge  $Q$  on the capacitor when it is fully charged. (b) Which plate is at the higher potential? (c) Discuss the force that causes the separation of charges.

63. A rectangular coil of 60 turns, dimensions 0.100 m by 0.200 m and total resistance  $10.0 \Omega$ , rotates with angular speed  $30.0 \text{ rad/s}$  about the  $y$  axis in a region where a  $1.00\text{-T}$  magnetic field is directed along the  $x$  axis. The rotation is initiated so that the plane of the coil is perpendicular to the direction of  $\mathbf{B}$  at  $t = 0$ . Calculate (a) the maximum induced emf in the coil, (b) the maximum rate of change of magnetic flux through the coil, (c) the induced emf at  $t = 0.050 \text{ s}$ , and (d) the torque exerted on the coil by the magnetic field at the instant when the emf is a maximum.
64. A small circular washer of radius  $0.500 \text{ cm}$  is held directly below a long, straight wire carrying a current of  $10.0 \text{ A}$ . The washer is located  $0.500 \text{ m}$  above the top of the table (Fig. P31.64). (a) If the washer is dropped from rest, what is the magnitude of the average induced

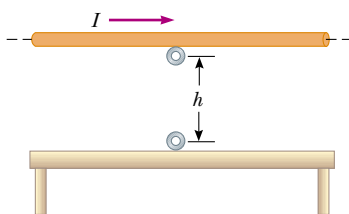

Figure P31.64

emf in the washer from the time it is released to the moment it hits the tabletop? Assume that the magnetic field is nearly constant over the area of the washer and equal to the magnetic field at the center of the washer. (b) What is the direction of the induced current in the washer?

65. To monitor the breathing of a hospital patient, a thin belt is wrapped around the patient's chest. The belt is a 200-turn coil. When the patient inhales, the area encircled by the coil increases by  $39.0 \text{ cm}^2$ . The magnitude of the Earth's magnetic field is  $50.0 \mu\text{T}$  and makes an angle of  $28.0^\circ$  with the plane of the coil. If a patient takes  $1.80 \text{ s}$  to inhale, find the average induced emf in the coil during this time.
66. A conducting rod of length  $\ell$  moves with velocity  $\mathbf{v}$  parallel to a long wire carrying a steady current  $I$ . The axis of the rod is maintained perpendicular to the wire with the near end a distance  $r$  away, as shown in Figure P31.66. Show that the magnitude of the emf induced in the rod is

$$|\mathcal{E}| = \frac{\mu_0 I}{2\pi} v \ln\left(1 + \frac{\ell}{r}\right)$$

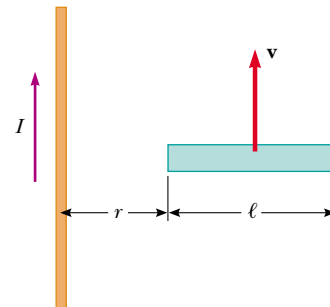

Figure P31.66

67. A rectangular loop of dimensions  $\ell$  and  $w$  moves with a constant velocity  $\mathbf{v}$  away from a long wire that carries a current  $I$  in the plane of the loop (Fig. P31.67). The to-

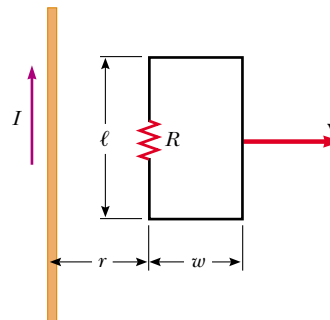

Figure P31.67

tal resistance of the loop is  $R$ . Derive an expression that gives the current in the loop at the instant the near side is a distance  $r$  from the wire.

68. A horizontal wire is free to slide on the vertical rails of a conducting frame, as shown in Figure P31.68. The wire has mass  $m$  and length  $\ell$ , and the resistance of the circuit is  $R$ . If a uniform magnetic field is directed perpendicular to the frame, what is the terminal speed of the wire as it falls under the force of gravity?

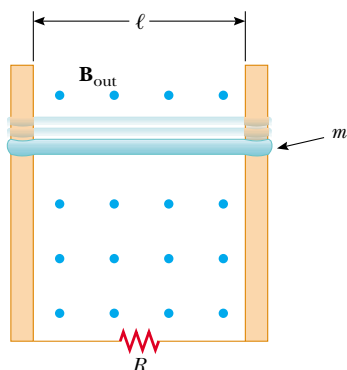

Figure P31.68

69. The magnetic flux threading a metal ring varies with time  $t$  according to  $\Phi_B = 3(at^3 - bt^2)$  T·m<sup>2</sup>, with  $a = 2.00$  s<sup>-3</sup> and  $b = 6.00$  s<sup>-2</sup>. The resistance of the ring is  $3.00$   $\Omega$ . Determine the maximum current induced in the ring during the interval from  $t = 0$  to  $t = 2.00$  s.
70. **Review Problem.** The bar of mass  $m$  shown in Figure P31.70 is pulled horizontally across parallel rails by a massless string that passes over an ideal pulley and is attached to a suspended mass  $M$ . The uniform magnetic field has a magnitude  $B$ , and the distance between the rails is  $\ell$ . The rails are connected at one end by a load resistor  $R$ . Derive an expression that gives the horizon-

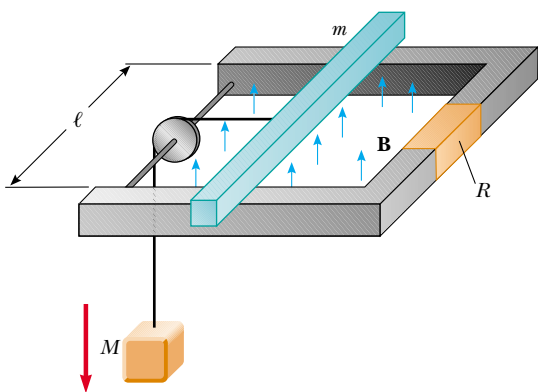

Figure P31.70

tal speed of the bar as a function of time, assuming that the suspended mass is released with the bar at rest at  $t = 0$ . Assume no friction between rails and bar.

71. A solenoid wound with 2 000 turns/m is supplied with current that varies in time according to  $I = 4 \sin(120\pi t)$ , where  $I$  is in A and  $t$  is in s. A small coaxial circular coil of 40 turns and radius  $r = 5.00$  cm is located inside the solenoid near its center. (a) Derive an expression that describes the manner in which the emf in the small coil varies in time. (b) At what average rate is energy transformed into internal energy in the small coil if the windings have a total resistance of  $8.00$   $\Omega$ ?
72. A wire 30.0 cm long is held parallel to and 80.0 cm above a long wire carrying 200 A and resting on the floor (Fig. P31.72). The 30.0-cm wire is released and falls, remaining parallel with the current-carrying wire as it falls. Assume that the falling wire accelerates at  $9.80$  m/s<sup>2</sup> and derive an equation for the emf induced in it. Express your result as a function of the time  $t$  after the wire is dropped. What is the induced emf 0.300 s after the wire is released?

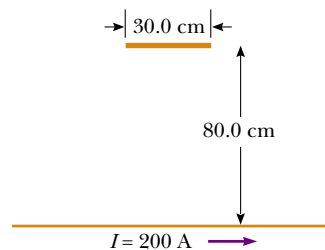

Figure P31.72

- WEB 73. A long, straight wire carries a current  $I = I_{\max} \sin(\omega t + \phi)$  and lies in the plane of a rectangular coil of  $N$  turns of wire, as shown in Figure P31.9. The quantities  $I_{\max}$ ,  $\omega$ , and  $\phi$  are all constants. Determine the emf induced in the coil by the magnetic field created by the current in the straight wire. Assume  $I_{\max} = 50.0$  A,  $\omega = 200\pi$  s<sup>-1</sup>,  $N = 100$ ,  $h = w = 5.00$  cm, and  $L = 20.0$  cm.
74. A dime is suspended from a thread and hung between the poles of a strong horseshoe magnet as shown in Figure P31.74. The dime rotates at constant angular speed  $\omega$  about a vertical axis. Letting  $\theta$  represent the angle between the direction of  $\mathbf{B}$  and the normal to the face of the dime, sketch a graph of the torque due to induced currents as a function of  $\theta$  for  $0 < \theta < 2\pi$ .
75. The wire shown in Figure P31.75 is bent in the shape of a tent, with  $\theta = 60.0^\circ$  and  $L = 1.50$  m, and is placed in a uniform magnetic field of magnitude 0.300 T perpendicular to the tabletop. The wire is rigid but hinged at points  $a$  and  $b$ . If the "tent" is flattened out on the table in 0.100 s, what is the average induced emf in the wire during this time?

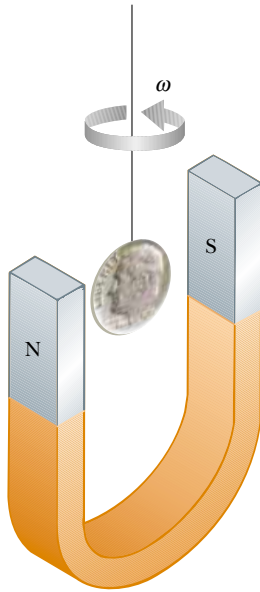

Figure P31.74

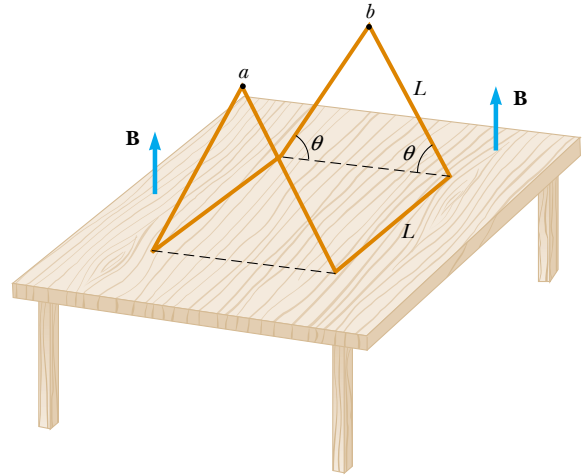

Figure P31.75

## ANSWERS TO QUICK QUIZZES

- 31.1** Because the magnetic field now points in the opposite direction, you must replace  $\theta$  with  $\theta + \pi$ . Because  $\cos(\theta + \pi) = -\cos \theta$ , the sign of the induced emf is reversed.
- 31.2** The one on the west side of the plane. As we saw in Section 30.9, the Earth's magnetic field has a downward component in the northern hemisphere. As the plane flies north, the right-hand rule illustrated in Figure 29.4 indicates that positive charge experiences a force directed toward the west. Thus, the left wingtip becomes positively charged and the right wingtip negatively charged.
- 31.3** Inserting. Because the south pole of the magnet is nearest the solenoid, the field lines created by the magnet point upward in Figure 31.14. Because the current induced in the solenoid is clockwise when viewed from above, the magnetic field lines produced by this current point downward in Figure 31.14. If the magnet were being withdrawn, it would create a decreasing upward flux. The induced current would counteract this decrease by producing its own upward flux. This would require a counterclockwise current in the solenoid, contrary to what is observed.