

PUZZLER

The brilliant colors seen in peacock feathers are not caused by pigments in the feathers. If they are not produced by pigments, how are these beautiful colors created? (Terry Qing/FPG International)

chapter

37

Interference of Light Waves

Chapter Outline

- 37.1** Conditions for Interference
- 37.2** Young's Double-Slit Experiment
- 37.3** Intensity Distribution of the Double-Slit Interference Pattern
- 37.4** Phasor Addition of Waves

- 37.5** Change of Phase Due to Reflection
- 37.6** Interference in Thin Films
- 37.7** (Optional) The Michelson Interferometer

In the preceding chapter on geometric optics, we used light rays to examine what happens when light passes through a lens or reflects from a mirror. Here in Chapter 37 and in the next chapter, we are concerned with *wave optics*, the study of interference, diffraction, and polarization of light. These phenomena cannot be adequately explained with the ray optics used in Chapter 36. We now learn how treating light as waves rather than as rays leads to a satisfying description of such phenomena.

37.1 CONDITIONS FOR INTERFERENCE

In Chapter 18, we found that the adding together of two mechanical waves can be constructive or destructive. In constructive interference, the amplitude of the resultant wave is greater than that of either individual wave, whereas in destructive interference, the resultant amplitude is less than that of either individual wave. Light waves also interfere with each other. Fundamentally, all interference associated with light waves arises when the electromagnetic fields that constitute the individual waves combine.

If two lightbulbs are placed side by side, no interference effects are observed because the light waves from one bulb are emitted independently of those from the other bulb. The emissions from the two lightbulbs do not maintain a constant phase relationship with each other over time. Light waves from an ordinary source such as a lightbulb undergo random changes about once every 10^{-8} s. Therefore, the conditions for constructive interference, destructive interference, or some intermediate state last for lengths of time of the order of 10^{-8} s. Because the eye cannot follow such short-term changes, no interference effects are observed. (In 1993 interference from two separate light sources was photographed in an extremely fast exposure. Nonetheless, we do not ordinarily see interference effects because of the rapidly changing phase relationship between the light waves.) Such light sources are said to be **incoherent**.

Interference effects in light waves are not easy to observe because of the short wavelengths involved (from 4×10^{-7} m to 7×10^{-7} m). For sustained interference in light waves to be observed, the following conditions must be met:

- The sources must be **coherent**—that is, they must maintain a constant phase with respect to each other.
- The sources should be **monochromatic**—that is, of a single wavelength.

We now describe the characteristics of coherent sources. As we saw when we studied mechanical waves, two sources (producing two traveling waves) are needed to create interference. In order to produce a stable interference pattern, **the individual waves must maintain a constant phase relationship with one another**. As an example, the sound waves emitted by two side-by-side loudspeakers driven by a single amplifier can interfere with each other because the two speakers are coherent—that is, they respond to the amplifier in the same way at the same time.

A common method for producing two coherent light sources is to use one monochromatic source to illuminate a barrier containing two small openings (usually in the shape of slits). The light emerging from the two slits is coherent because a single source produces the original light beam and the two slits serve only to separate the original beam into two parts (which, after all, is what was done to the sound signal from the side-by-side loudspeakers). Any random change in the light

emitted by the source occurs in both beams at the same time, and as a result interference effects can be observed when the light from the two slits arrives at a viewing screen.

37.2 YOUNG'S DOUBLE-SLIT EXPERIMENT

Interference in light waves from two sources was first demonstrated by Thomas Young in 1801. A schematic diagram of the apparatus that Young used is shown in Figure 37.1a. Light is incident on a first barrier in which there is a slit S_0 . The waves emerging from this slit arrive at a second barrier that contains two parallel slits S_1 and S_2 . These two slits serve as a pair of coherent light sources because waves emerging from them originate from the same wave front and therefore maintain a constant phase relationship. The light from S_1 and S_2 produces on a viewing screen a visible pattern of bright and dark parallel bands called **fringes** (Fig. 37.1b). When the light from S_1 and that from S_2 both arrive at a point on the screen such that constructive interference occurs at that location, a bright fringe appears. When the light from the two slits combines destructively at any location on the screen, a dark fringe results. Figure 37.2 is a photograph of an interference pattern produced by two coherent vibrating sources in a water tank.

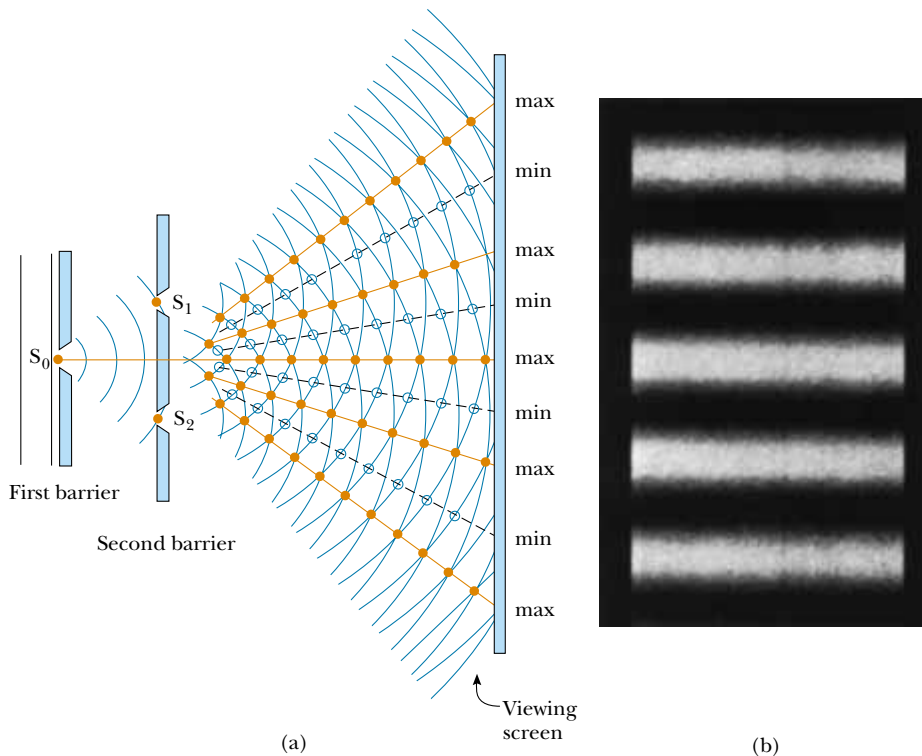

Figure 37.1 (a) Schematic diagram of Young's double-slit experiment. Slits S_1 and S_2 behave as coherent sources of light waves that produce an interference pattern on the viewing screen (drawing not to scale). (b) An enlargement of the center of a fringe pattern formed on the viewing screen with many slits could look like this.

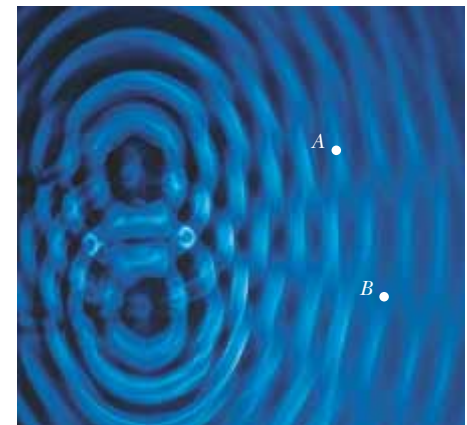

Figure 37.2 An interference pattern involving water waves is produced by two vibrating sources at the water's surface. The pattern is analogous to that observed in Young's double-slit experiment. Note the regions of constructive (A) and destructive (B) interference.

Quick Quiz 37.1

If you were to blow smoke into the space between the second barrier and the viewing screen of Figure 37.1a, what would you see?

QuickLab

Look through the fabric of an umbrella at a distant streetlight. Can you explain what you see? (The fringe pattern in Figure 37.1b is from rectangular slits. The fabric of the umbrella creates a two-dimensional set of square holes.)

Quick Quiz 37.2

Figure 37.2 is an overhead view of a shallow water tank. If you wanted to use a small ruler to measure the water's depth, would this be easier to do at location *A* or at location *B*?

Figure 37.3 shows some of the ways in which two waves can combine at the screen. In Figure 37.3a, the two waves, which leave the two slits in phase, strike the screen at the central point *P*. Because both waves travel the same distance, they arrive at *P* in phase. As a result, constructive interference occurs at this location, and a bright fringe is observed. In Figure 37.3b, the two waves also start in phase, but in this case the upper wave has to travel one wavelength farther than the lower wave to reach point *Q*. Because the upper wave falls behind the lower one by exactly one wavelength, they still arrive in phase at *Q*, and so a second bright fringe appears at this location. At point *R* in Figure 37.3c, however, midway between points *P* and *Q*, the upper wave has fallen half a wavelength behind the lower wave. This means that a trough of the lower wave overlaps a crest of the upper wave; this gives rise to destructive interference at point *R*. For this reason, a dark fringe is observed at this location.

We can describe Young's experiment quantitatively with the help of Figure 37.4. The viewing screen is located a perpendicular distance *L* from the double-slitted barrier. *S*₁ and *S*₂ are separated by a distance *d*, and the source is monochromatic. To reach any arbitrary point *P*, a wave from the lower slit travels farther than a wave from the upper slit by a distance $d \sin \theta$. This distance is called the **path difference** δ (lowercase Greek delta). If we assume that *r*₁ and *r*₂ are parallel, which is approximately true because *L* is much greater than *d*, then δ is given by

Path difference

$$\delta = r_2 - r_1 = d \sin \theta \quad (37.1)$$

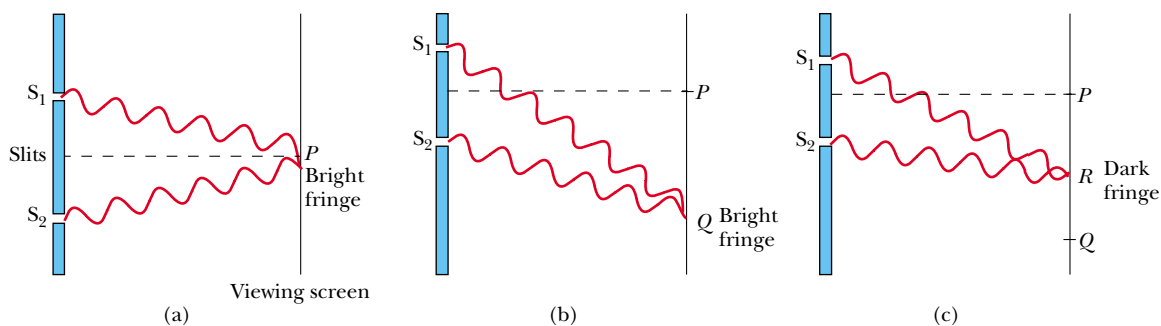

Figure 37.3 (a) Constructive interference occurs at point *P* when the waves combine. (b) Constructive interference also occurs at point *Q*. (c) Destructive interference occurs at *R* when the two waves combine because the upper wave falls half a wavelength behind the lower wave (all figures not to scale).

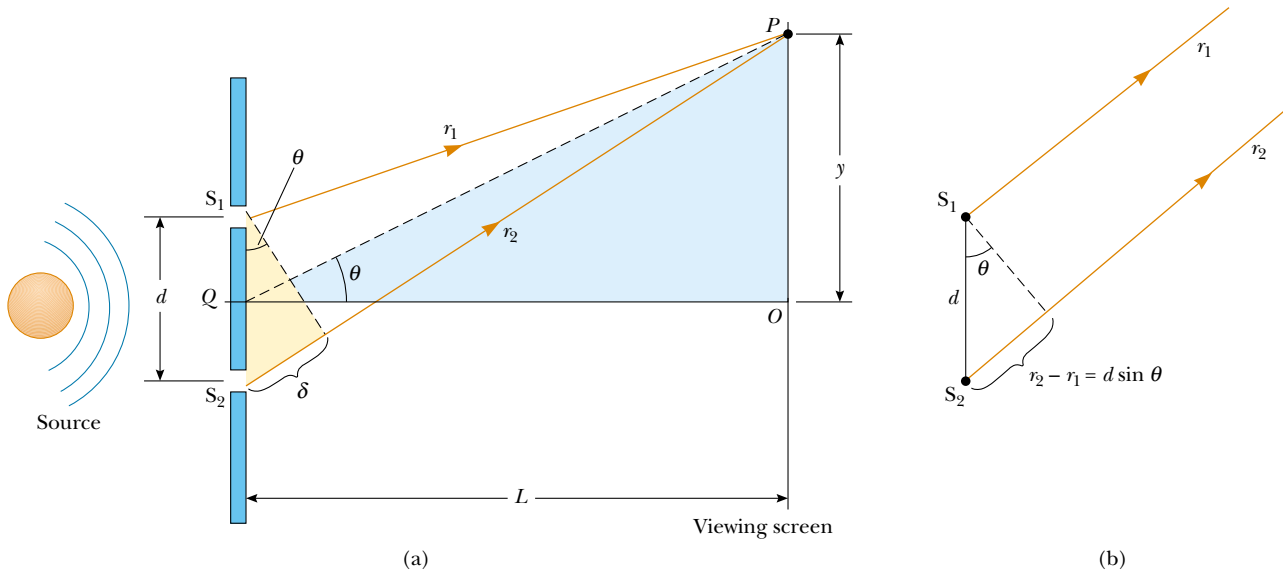

Figure 37.4 (a) Geometric construction for describing Young's double-slit experiment (not to scale). (b) When we assume that r_1 is parallel to r_2 , the path difference between the two rays is $r_2 - r_1 = d \sin \theta$. For this approximation to be valid, it is essential that $L \gg d$.

The value of δ determines whether the two waves are in phase when they arrive at point P . If δ is either zero or some integer multiple of the wavelength, then the two waves are in phase at point P and constructive interference results. Therefore, the condition for bright fringes, or **constructive interference**, at point P is

$$\delta = d \sin \theta = m\lambda \quad m = 0, \pm 1, \pm 2, \dots \quad (37.2)$$

Conditions for constructive interference

The number m is called the **order number**. The central bright fringe at $\theta = 0$ ($m = 0$) is called the *zeroth-order maximum*. The first maximum on either side, where $m = \pm 1$, is called the *first-order maximum*, and so forth.

When δ is an odd multiple of $\lambda/2$, the two waves arriving at point P are 180° out of phase and give rise to destructive interference. Therefore, the condition for dark fringes, or **destructive interference**, at point P is

$$d \sin \theta = (m + \frac{1}{2})\lambda \quad m = 0, \pm 1, \pm 2, \dots \quad (37.3)$$

Conditions for destructive interference

It is useful to obtain expressions for the positions of the bright and dark fringes measured vertically from O to P . In addition to our assumption that $L \gg d$, we assume that $d \gg \lambda$. These can be valid assumptions because in practice L is often of the order of 1 m, d a fraction of a millimeter, and λ a fraction of a micrometer for visible light. Under these conditions, θ is small; thus, we can use the approximation $\sin \theta \approx \tan \theta$. Then, from triangle OPQ in Figure 37.4, we see that

$$y = L \tan \theta \approx L \sin \theta \quad (37.4)$$

Solving Equation 37.2 for $\sin \theta$ and substituting the result into Equation 37.4, we see that the positions of the bright fringes measured from O are given by the expression

$$y_{\text{bright}} = \frac{\lambda L}{d} m \quad (37.5)$$

Using Equations 37.3 and 37.4, we find that the dark fringes are located at

$$y_{\text{dark}} = \frac{\lambda L}{d} \left(m + \frac{1}{2} \right) \quad (37.6)$$

As we demonstrate in Example 37.1, Young's double-slit experiment provides a method for measuring the wavelength of light. In fact, Young used this technique to do just that. Additionally, the experiment gave the wave model of light a great deal of credibility. It was inconceivable that particles of light coming through the slits could cancel each other in a way that would explain the dark fringes.

EXAMPLE 37.1 Measuring the Wavelength of a Light Source

A viewing screen is separated from a double-slit source by 1.2 m. The distance between the two slits is 0.030 mm. The second-order bright fringe ($m = 2$) is 4.5 cm from the center line. (a) Determine the wavelength of the light.

Solution We can use Equation 37.5, with $m = 2$, $y_2 = 4.5 \times 10^{-2}$ m, $L = 1.2$ m, and $d = 3.0 \times 10^{-5}$ m:

$$\begin{aligned} \lambda &= \frac{dy_2}{mL} = \frac{(3.0 \times 10^{-5} \text{ m})(4.5 \times 10^{-2} \text{ m})}{2(1.2 \text{ m})} \\ &= 5.6 \times 10^{-7} \text{ m} = \boxed{560 \text{ nm}} \end{aligned}$$

(b) Calculate the distance between adjacent bright fringes.

Solution From Equation 37.5 and the results of part (a), we obtain

$$\begin{aligned} y_{m+1} - y_m &= \frac{\lambda L(m+1)}{d} - \frac{\lambda Lm}{d} \\ &= \frac{\lambda L}{d} = \frac{(5.6 \times 10^{-7} \text{ m})(1.2 \text{ m})}{3.0 \times 10^{-5} \text{ m}} \\ &= 2.2 \times 10^{-2} \text{ m} = \boxed{2.2 \text{ cm}} \end{aligned}$$

Note that the spacing between all fringes is equal.

EXAMPLE 37.2 Separating Double-Slit Fringes of Two Wavelengths

A light source emits visible light of two wavelengths: $\lambda = 430$ nm and $\lambda' = 510$ nm. The source is used in a double-slit interference experiment in which $L = 1.5$ m and $d = 0.025$ mm. Find the separation distance between the third-order bright fringes.

Solution Using Equation 37.5, with $m = 3$, we find that the fringe positions corresponding to these two wavelengths are

$$y_3 = \frac{\lambda L}{d} m = 3 \frac{\lambda L}{d} = 7.74 \times 10^{-2} \text{ m}$$

$$y'_3 = \frac{\lambda' L}{d} m = 3 \frac{\lambda' L}{d} = 9.18 \times 10^{-2} \text{ m}$$

Hence, the separation distance between the two fringes is

$$\begin{aligned} \Delta y &= y'_3 - y_3 = 9.18 \times 10^{-2} \text{ m} - 7.74 \times 10^{-2} \text{ m} \\ &= 1.4 \times 10^{-2} \text{ m} = \boxed{1.4 \text{ cm}} \end{aligned}$$

37.3 INTENSITY DISTRIBUTION OF THE DOUBLE-SLIT INTERFERENCE PATTERN

Note that the edges of the bright fringes in Figure 37.1b are fuzzy. So far we have discussed the locations of only the centers of the bright and dark fringes on a distant screen. We now direct our attention to the intensity of the light at other points between the positions of maximum constructive and destructive interference. In other words, we now calculate the distribution of light intensity associated with the double-slit interference pattern.

Again, suppose that the two slits represent coherent sources of sinusoidal waves such that the two waves from the slits have the same angular frequency ω and a constant phase difference ϕ . The total magnitude of the electric field at point P on the screen in Figure 37.5 is the vector superposition of the two waves. Assuming that the two waves have the same amplitude E_0 , we can write the magnitude of the electric field at point P due to each wave separately as

$$E_1 = E_0 \sin \omega t \quad \text{and} \quad E_2 = E_0 \sin(\omega t + \phi) \quad (37.7)$$

Although the waves are in phase at the slits, *their phase difference ϕ at point P depends on the path difference $\delta = r_2 - r_1 = d \sin \theta$* . Because a path difference of λ (constructive interference) corresponds to a phase difference of 2π rad, we obtain the ratio

$$\frac{\delta}{\lambda} = \frac{\phi}{2\pi}$$

$$\phi = \frac{2\pi}{\lambda} \delta = \frac{2\pi}{\lambda} d \sin \theta \quad (37.8)$$

This equation tells us precisely how the phase difference ϕ depends on the angle θ in Figure 37.4.

Using the superposition principle and Equation 37.7, we can obtain the magnitude of the resultant electric field at point P :

$$E_P = E_1 + E_2 = E_0[\sin \omega t + \sin(\omega t + \phi)] \quad (37.9)$$

To simplify this expression, we use the trigonometric identity

$$\sin A + \sin B = 2 \sin\left(\frac{A+B}{2}\right) \cos\left(\frac{A-B}{2}\right)$$

Taking $A = \omega t + \phi$ and $B = \omega t$, we can write Equation 37.9 in the form

$$E_P = 2E_0 \cos\left(\frac{\phi}{2}\right) \sin\left(\omega t + \frac{\phi}{2}\right) \quad (37.10)$$

This result indicates that the electric field at point P has the same frequency ω as the light at the slits, but that the amplitude of the field is multiplied by the factor $2 \cos(\phi/2)$. To check the consistency of this result, note that if $\phi = 0, 2\pi, 4\pi, \dots$, then the electric field at point P is $2E_0$, corresponding to the condition for constructive interference. These values of ϕ are consistent with Equation 37.2 for constructive interference. Likewise, if $\phi = \pi, 3\pi, 5\pi, \dots$, then the magnitude of the electric field at point P is zero; this is consistent with Equation 37.3 for destructive interference.

Finally, to obtain an expression for the light intensity at point P , recall from Section 34.3 that *the intensity of a wave is proportional to the square of the resultant electric field magnitude at that point* (Eq. 34.20). Using Equation 37.10, we can therefore express the light intensity at point P as

$$I \propto E_P^2 = 4E_0^2 \cos^2\left(\frac{\phi}{2}\right) \sin^2\left(\omega t + \frac{\phi}{2}\right)$$

Most light-detecting instruments measure time-averaged light intensity, and the time-averaged value of $\sin^2(\omega t + \phi/2)$ over one cycle is $\frac{1}{2}$. Therefore, we can write the average light intensity at point P as

$$I = I_{\max} \cos^2\left(\frac{\phi}{2}\right) \quad (37.11)$$

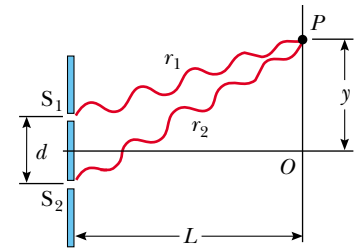

Figure 37.5 Construction for analyzing the double-slit interference pattern. A bright fringe, or intensity maximum, is observed at O .

Phase difference

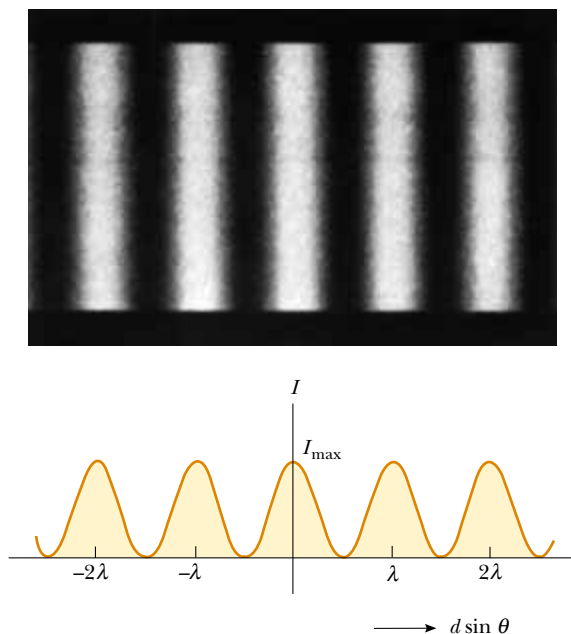

Figure 37.6 Light intensity versus $d \sin \theta$ for a double-slit interference pattern when the screen is far from the slits ($L \gg d$).

where I_{\max} is the maximum intensity on the screen and the expression represents the time average. Substituting the value for ϕ given by Equation 37.8 into this expression, we find that

$$I = I_{\max} \cos^2\left(\frac{\pi d \sin \theta}{\lambda}\right) \quad (37.12)$$

Alternatively, because $\sin \theta \approx y/L$ for small values of θ in Figure 37.4, we can write Equation 37.12 in the form

$$I = I_{\max} \cos^2\left(\frac{\pi d}{\lambda L} y\right) \quad (37.13)$$

Constructive interference, which produces light intensity maxima, occurs when the quantity $\pi dy/\lambda L$ is an integral multiple of π , corresponding to $y = (\lambda L/d)m$. This is consistent with Equation 37.5.

A plot of light intensity versus $d \sin \theta$ is given in Figure 37.6. Note that the interference pattern consists of equally spaced fringes of equal intensity. Remember, however, that this result is valid only if the slit-to-screen distance L is much greater than the slit separation, and only for small values of θ .

We have seen that the interference phenomena arising from two sources depend on the relative phase of the waves at a given point. Furthermore, the phase difference at a given point depends on the path difference between the two waves. **The resultant light intensity at a point is proportional to the square of the resultant electric field at that point.** That is, the light intensity is proportional to $(E_1 + E_2)^2$. It would be incorrect to calculate the light intensity by adding the intensities of the individual waves. This procedure would give $E_1^2 + E_2^2$, which of course is not the same as $(E_1 + E_2)^2$. Note, however, that $(E_1 + E_2)^2$ has the same *average* value as $E_1^2 + E_2^2$ when the time average is taken over all values of the

phase difference between E_1 and E_2 . Hence, the law of conservation of energy is not violated.

37.4 PHASOR ADDITION OF WAVES

In the preceding section, we combined two waves algebraically to obtain the resultant wave amplitude at some point on a screen. Unfortunately, this analytical procedure becomes cumbersome when we must add several wave amplitudes. Because we shall eventually be interested in combining a large number of waves, we now describe a graphical procedure for this purpose.

Let us again consider a sinusoidal wave whose electric field component is given by

$$E_1 = E_0 \sin \omega t$$

where E_0 is the wave amplitude and ω is the angular frequency. This wave can be represented graphically by a phasor of magnitude E_0 rotating about the origin counterclockwise with an angular frequency ω , as shown in Figure 37.7a. Note that the phasor makes an angle ωt with the horizontal axis. The projection of the phasor on the vertical axis represents E_1 , the magnitude of the wave disturbance at some time t . Hence, as the phasor rotates in a circle, the projection E_1 oscillates along the vertical axis about the origin.

Now consider a second sinusoidal wave whose electric field component is given by

$$E_2 = E_0 \sin(\omega t + \phi)$$

This wave has the same amplitude and frequency as E_1 , but its phase is ϕ with respect to E_1 . The phasor representing E_2 is shown in Figure 37.7b. We can obtain the resultant wave, which is the sum of E_1 and E_2 , graphically by redrawing the phasors as shown in Figure 37.7c, in which the tail of the second phasor is placed at the tip of the first. As with vector addition, the resultant phasor \mathbf{E}_R runs from the tail of the first phasor to the tip of the second. Furthermore, \mathbf{E}_R rotates along with the two individual phasors at the same angular frequency ω . The projection of \mathbf{E}_R along the vertical axis equals the sum of the projections of the two other phasors: $E_P = E_1 + E_2$.

It is convenient to construct the phasors at $t = 0$ as in Figure 37.8. From the geometry of one of the right triangles, we see that

$$\cos \alpha = \frac{E_R/2}{E_0}$$

which gives

$$E_R = 2E_0 \cos \alpha$$

Because the sum of the two opposite interior angles equals the exterior angle ϕ , we see that $\alpha = \phi/2$; thus,

$$E_R = 2E_0 \cos\left(\frac{\phi}{2}\right)$$

Hence, the projection of the phasor \mathbf{E}_R along the vertical axis at any time t is

$$E_P = E_R \sin\left(\omega t + \frac{\phi}{2}\right) = 2E_0 \cos\left(\frac{\phi}{2}\right) \sin\left(\omega t + \frac{\phi}{2}\right)$$

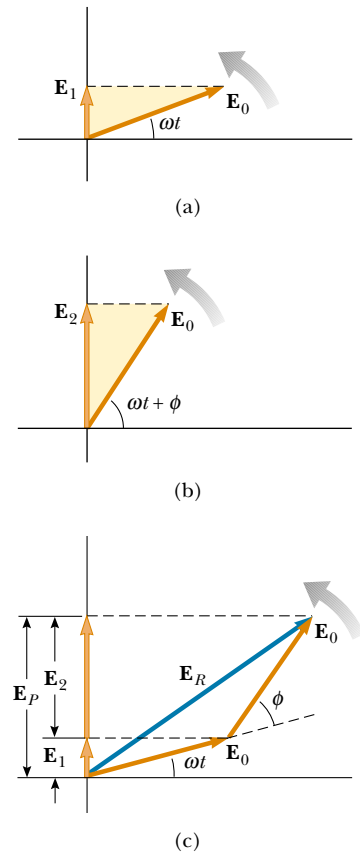

Figure 37.7 (a) Phasor diagram for the wave disturbance $E_1 = E_0 \sin \omega t$. The phasor is a vector of length E_0 rotating counterclockwise. (b) Phasor diagram for the wave $E_2 = E_0 \sin(\omega t + \phi)$. (c) The disturbance \mathbf{E}_R is the resultant phasor formed from the phasors of parts (a) and (b).

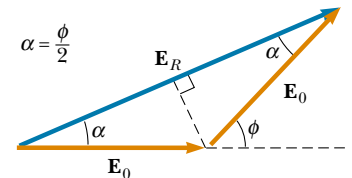

Figure 37.8 A reconstruction of the resultant phasor \mathbf{E}_R . From the geometry, note that $\alpha = \phi/2$.

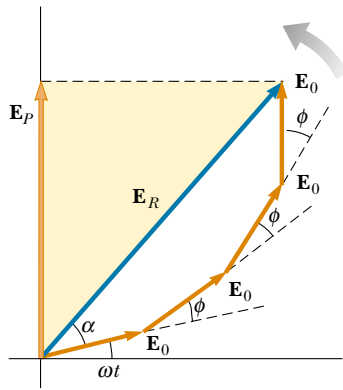

Figure 37.9 The phasor \mathbf{E}_R is the resultant of four phasors of equal amplitude E_0 . The phase of \mathbf{E}_R with respect to the first phasor is α .

This is consistent with the result obtained algebraically, Equation 37.10. The resultant phasor has an amplitude $2E_0 \cos(\phi/2)$ and makes an angle $\phi/2$ with the first phasor. Furthermore, the average light intensity at point P , which varies as E_P^2 , is proportional to $\cos^2(\phi/2)$, as described in Equation 37.11.

We can now describe how to obtain the resultant of several waves that have the same frequency:

- Represent the waves by phasors, as shown in Figure 37.9, remembering to maintain the proper phase relationship between one phasor and the next.
- The resultant phasor \mathbf{E}_R is the vector sum of the individual phasors. At each instant, the projection of \mathbf{E}_R along the vertical axis represents the time variation of the resultant wave. The phase angle α of the resultant wave is the angle between \mathbf{E}_R and the first phasor. From Figure 37.9, drawn for four phasors, we see that the phasor of the resultant wave is given by the expression $E_P = E_R \sin(\omega t + \alpha)$.

Phasor Diagrams for Two Coherent Sources

As an example of the phasor method, consider the interference pattern produced by two coherent sources. Figure 37.10 represents the phasor diagrams for various values of the phase difference ϕ and the corresponding values of the path difference δ , which are obtained from Equation 37.8. The light intensity at a point is a maximum when \mathbf{E}_R is a maximum; this occurs at $\phi = 0, 2\pi, 4\pi, \dots$. The light intensity at some point is zero when \mathbf{E}_R is zero; this occurs at $\phi = \pi, 3\pi, 5\pi, \dots$. These results are in complete agreement with the analytical procedure described in the preceding section.

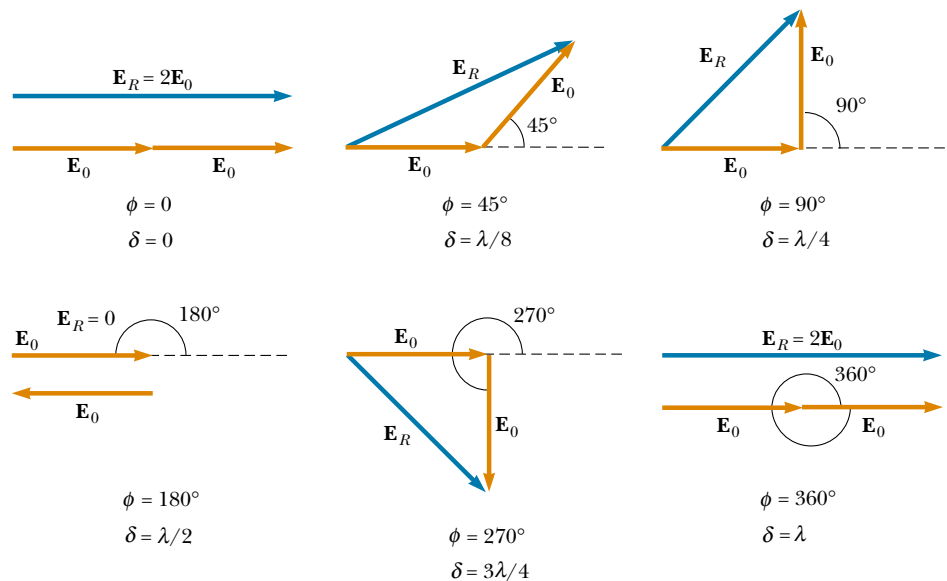

Figure 37.10 Phasor diagrams for a double-slit interference pattern. The resultant phasor \mathbf{E}_R is a maximum when $\phi = 0, 2\pi, 4\pi, \dots$ and is zero when $\phi = \pi, 3\pi, 5\pi, \dots$.

Three-Slit Interference Pattern

Using phasor diagrams, let us analyze the interference pattern caused by three equally spaced slits. We can express the electric field components at a point P on the screen caused by waves from the individual slits as

$$E_1 = E_0 \sin \omega t$$

$$E_2 = E_0 \sin(\omega t + \phi)$$

$$E_3 = E_0 \sin(\omega t + 2\phi)$$

where ϕ is the phase difference between waves from adjacent slits. We can obtain the resultant magnitude of the electric field at point P from the phasor diagram in Figure 37.11.

The phasor diagrams for various values of ϕ are shown in Figure 37.12. Note that the resultant magnitude of the electric field at P has a maximum value of $3E_0$, a condition that occurs when $\phi = 0, \pm 2\pi, \pm 4\pi, \dots$. These points are called *primary maxima*. Such primary maxima occur whenever the three phasors are aligned as shown in Figure 37.12a. We also find secondary maxima of amplitude E_0 occurring between the primary maxima at points where $\phi = \pm \pi, \pm 3\pi, \dots$. For these points, the wave from one slit exactly cancels that from another slit (Fig. 37.12d). This means that only light from the third slit contributes to the resultant, which consequently has a total amplitude of E_0 . Total destructive interference occurs whenever the three phasors form a closed triangle, as shown in Figure 37.12c. These points where $E_R = 0$ correspond to $\phi = \pm 2\pi/3, \pm 4\pi/3, \dots$. You should be able to construct other phasor diagrams for values of ϕ greater than π .

Figure 37.13 shows multiple-slit interference patterns for a number of configurations. For three slits, note that the primary maxima are nine times more intense than the secondary maxima as measured by the height of the curve. This is because the intensity varies as E_R^2 . For N slits, the intensity of the primary maxima is N^2 times greater than that due to a single slit. As the number of slits increases, the primary maxima increase in intensity and become narrower, while the secondary maxima decrease in intensity relative to the primary maxima. Figure 37.13 also shows that as the number of slits increases, the number of secondary maxima also increases. In fact, the number of secondary maxima is always $N - 2$, where N is the number of slits.

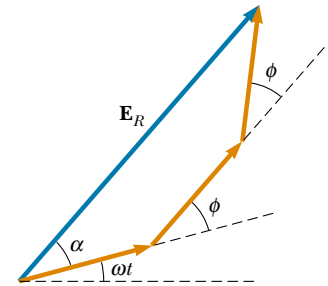

Figure 37.11 Phasor diagram for three equally spaced slits.

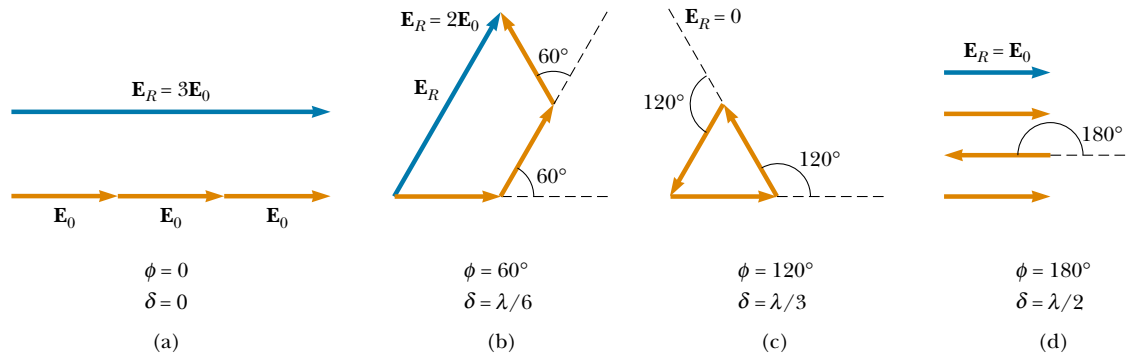

Figure 37.12 Phasor diagrams for three equally spaced slits at various values of ϕ . Note from (a) that there are primary maxima of amplitude $3E_0$ and from (d) that there are secondary maxima of amplitude E_0 .

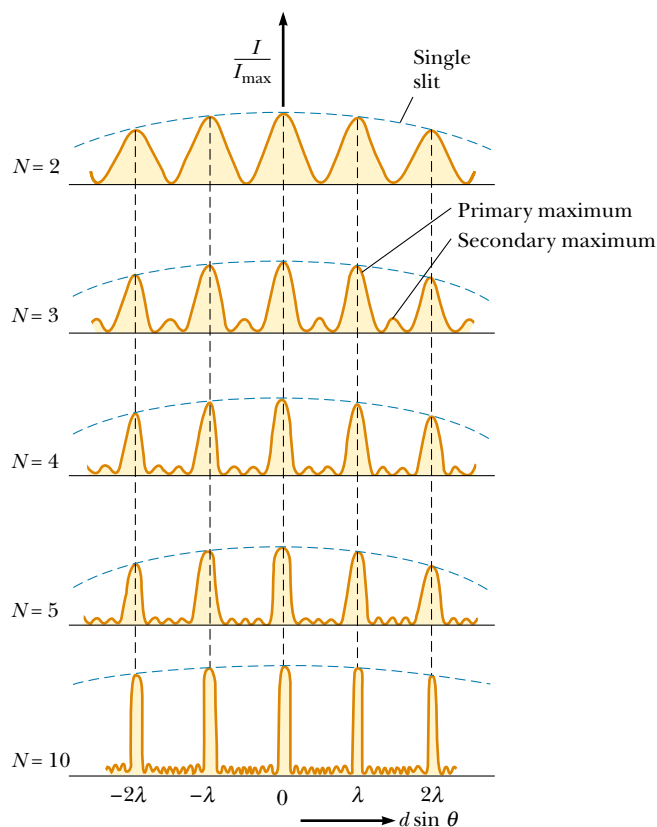

Figure 37.13 Multiple-slit interference patterns. As N , the number of slits, is increased, the primary maxima (the tallest peaks in each graph) become narrower but remain fixed in position, and the number of secondary maxima increases. For any value of N , the decrease in intensity in maxima to the left and right of the central maximum, indicated by the blue dashed arcs, is due to diffraction, which is discussed in Chapter 38.

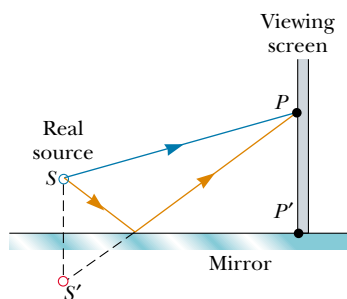

Figure 37.14 Lloyd's mirror. An interference pattern is produced at point P on the screen as a result of the combination of the direct ray (blue) and the reflected ray (red). The reflected ray undergoes a phase change of 180° .

Quick Quiz 37.3

Using Figure 37.13 as a model, sketch the interference pattern from six slits.

37.5 CHANGE OF PHASE DUE TO REFLECTION

Young's method for producing two coherent light sources involves illuminating a pair of slits with a single source. Another simple, yet ingenious, arrangement for producing an interference pattern with a single light source is known as *Lloyd's mirror* (Fig. 37.14). A light source is placed at point S close to a mirror, and a viewing screen is positioned some distance away at right angles to the mirror. Light waves can reach point P on the screen either by the direct path SP or by the path involving reflection from the mirror. The reflected ray can be treated as a ray originating from a virtual source at point S' . As a result, we can think of this arrangement as a double-slit source with the distance between

points S and S' comparable to length d in Figure 37.4. Hence, at observation points far from the source ($L \gg d$), we expect waves from points S and S' to form an interference pattern just like the one we see from two real coherent sources. An interference pattern is indeed observed. However, the positions of the dark and bright fringes are reversed relative to the pattern created by two real coherent sources (Young's experiment). This is because the coherent sources at points S and S' differ in phase by 180° , a phase change produced by reflection.

To illustrate this further, consider point P' , the point where the mirror intersects the screen. This point is equidistant from points S and S' . If path difference alone were responsible for the phase difference, we would see a bright fringe at point P' (because the path difference is zero for this point), corresponding to the central bright fringe of the two-slit interference pattern. Instead, we observe a dark fringe at point P' because of the 180° phase change produced by reflection. In general,

an electromagnetic wave undergoes a phase change of 180° upon reflection from a medium that has a higher index of refraction than the one in which the wave is traveling.

It is useful to draw an analogy between reflected light waves and the reflections of a transverse wave pulse on a stretched string (see Section 16.6). The reflected pulse on a string undergoes a phase change of 180° when reflected from the boundary of a denser medium, but no phase change occurs when the pulse is reflected from the boundary of a less dense medium. Similarly, an electromagnetic wave undergoes a 180° phase change when reflected from a boundary leading to an optically denser medium, but no phase change occurs when the wave is reflected from a boundary leading to a less dense medium. These rules, summarized in Figure 37.15, can be deduced from Maxwell's equations, but the treatment is beyond the scope of this text.

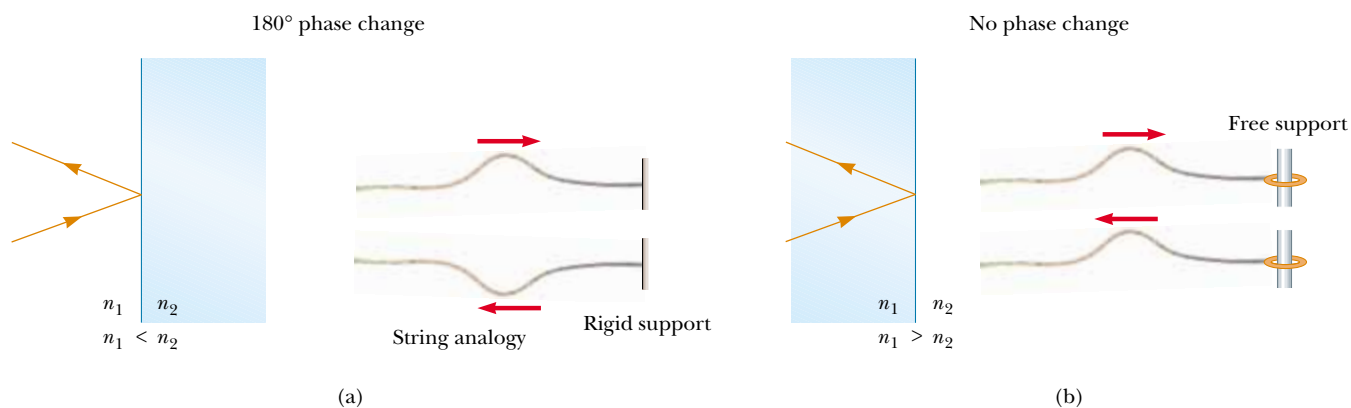

Figure 37.15 (a) For $n_1 < n_2$, a light ray traveling in medium 1 when reflected from the surface of medium 2 undergoes a 180° phase change. The same thing happens with a reflected pulse traveling along a string fixed at one end. (b) For $n_1 > n_2$, a light ray traveling in medium 1 undergoes no phase change when reflected from the surface of medium 2. The same is true of a reflected wave pulse on a string whose supported end is free to move.

37.6 INTERFERENCE IN THIN FILMS

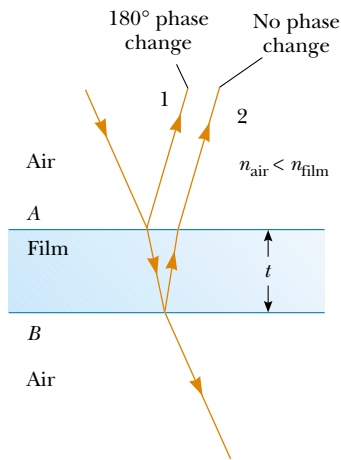

Figure 37.16 Interference in light reflected from a thin film is due to a combination of rays reflected from the upper and lower surfaces of the film.

Interference effects are commonly observed in thin films, such as thin layers of oil on water or the thin surface of a soap bubble. The varied colors observed when white light is incident on such films result from the interference of waves reflected from the two surfaces of the film.

Consider a film of uniform thickness t and index of refraction n , as shown in Figure 37.16. Let us assume that the light rays traveling in air are nearly normal to the two surfaces of the film. To determine whether the reflected rays interfere constructively or destructively, we first note the following facts:

- A wave traveling from a medium of index of refraction n_1 toward a medium of index of refraction n_2 undergoes a 180° phase change upon reflection when $n_2 > n_1$ and undergoes no phase change if $n_2 < n_1$.
- The wavelength of light λ_n in a medium whose refraction index is n (see Section 35.5) is

$$\lambda_n = \frac{\lambda}{n} \quad (37.14)$$

where λ is the wavelength of the light in free space.

Let us apply these rules to the film of Figure 37.16, where $n_{\text{film}} > n_{\text{air}}$. Reflected ray 1, which is reflected from the upper surface (A), undergoes a phase change of 180° with respect to the incident wave. Reflected ray 2, which is reflected from the lower film surface (B), undergoes no phase change because it is reflected from a medium (air) that has a lower index of refraction. Therefore, ray 1 is 180° out of phase with ray 2, which is equivalent to a path difference of $\lambda_n/2$.



Interference in soap bubbles. The colors are due to interference between light rays reflected from the front and back surfaces of the thin film of soap making up the bubble. The color depends on the thickness of the film, ranging from black where the film is thinnest to red where it is thickest.



 The brilliant colors in a peacock's feathers are due to interference. The multilayer structure of the feathers causes constructive interference for certain colors, such as blue and green. The colors change as you view a peacock's feathers from different angles. Iridescent colors of butterflies and hummingbirds are the result of similar interference effects.

However, we must also consider that ray 2 travels an extra distance $2t$ before the waves recombine in the air above surface A . If $2t = \lambda_n/2$, then rays 1 and 2 recombine in phase, and the result is constructive interference. In general, the condition for constructive interference in such situations is

$$2t = (m + \frac{1}{2})\lambda_n \quad m = 0, 1, 2, \dots \quad (37.15)$$

This condition takes into account two factors: (1) the difference in path length for the two rays (the term $m\lambda_n$) and (2) the 180° phase change upon reflection (the term $\lambda_n/2$). Because $\lambda_n = \lambda/n$, we can write Equation 37.15 as

$$2nt = (m + \frac{1}{2})\lambda \quad m = 0, 1, 2, \dots \quad (37.16)$$

If the extra distance $2t$ traveled by ray 2 corresponds to a multiple of λ_n , then the two waves combine out of phase, and the result is destructive interference. The general equation for destructive interference is

$$2nt = m\lambda \quad m = 0, 1, 2, \dots \quad (37.17)$$

The foregoing conditions for constructive and destructive interference are valid when the medium above the top surface of the film is the same as the medium below the bottom surface. The medium surrounding the film may have a refractive index less than or greater than that of the film. In either case, the rays reflected from the two surfaces are out of phase by 180° . If the film is placed between two different media, one with $n < n_{\text{film}}$ and the other with $n > n_{\text{film}}$, then the conditions for constructive and destructive interference are reversed. In this case, either there is a phase change of 180° for both ray 1 reflecting from surface A and ray 2 reflecting from surface B , or there is no phase change for either ray; hence, the net change in relative phase due to the reflections is zero.

Quick Quiz 37.4

In Figure 37.17, where does the oil film thickness vary the least?

Newton's Rings

Another method for observing interference in light waves is to place a plano-convex lens on top of a flat glass surface, as shown in Figure 37.18a. With this arrangement, the air film between the glass surfaces varies in thickness from zero at the point of contact to some value t at point P . If the radius of curvature R of the lens is much greater than the distance r , and if the system is viewed from above using light of a single wavelength λ , a pattern of light and dark rings is observed, as shown in Figure 37.18b. These circular fringes, discovered by Newton, are called **Newton's rings**.

The interference effect is due to the combination of ray 1, reflected from the flat plate, with ray 2, reflected from the curved surface of the lens. Ray 1 undergoes a phase change of 180° upon reflection (because it is reflected from a medium of higher refractive index), whereas ray 2 undergoes no phase change (because it is reflected from a medium of lower refractive index). Hence, the conditions for constructive and destructive interference are given by Equations 37.16 and 37.17, respectively, with $n = 1$ because the film is air.

The contact point at O is dark, as seen in Figure 37.18b, because ray 1 undergoes a 180° phase change upon external reflection (from the flat surface); in con-

Conditions for constructive interference in thin films

Conditions for destructive interference in thin films



Figure 37.17 A thin film of oil floating on water displays interference, as shown by the pattern of colors produced when white light is incident on the film. Variations in film thickness produce the interesting color pattern. The razor blade gives one an idea of the size of the colored bands.

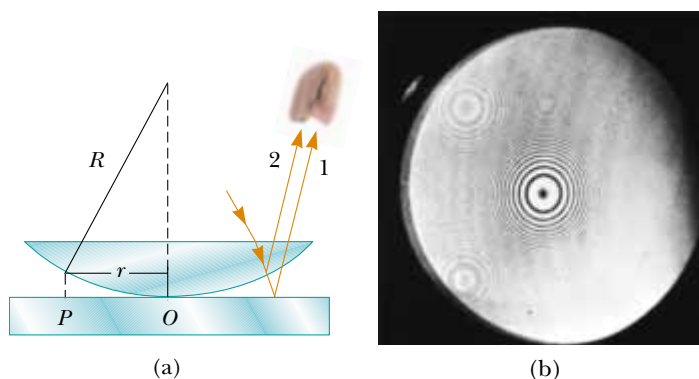

Figure 37.18 (a) The combination of rays reflected from the flat plate and the curved lens surface gives rise to an interference pattern known as Newton's rings. (b) Photograph of Newton's rings.

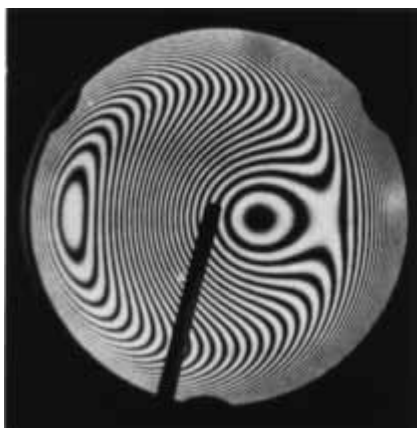

Figure 37.19 This asymmetrical interference pattern indicates imperfections in the lens of a Newton's-rings apparatus.

trast, ray 2 undergoes no phase change upon internal reflection (from the curved surface).

Using the geometry shown in Figure 37.18a, we can obtain expressions for the radii of the bright and dark bands in terms of the radius of curvature R and wavelength λ . For example, the dark rings have radii given by the expression $r \approx \sqrt{m\lambda R/n}$. The details are left as a problem for you to solve (see Problem 67). We can obtain the wavelength of the light causing the interference pattern by measuring the radii of the rings, provided R is known. Conversely, we can use a known wavelength to obtain R .

One important use of Newton's rings is in the testing of optical lenses. A circular pattern like that pictured in Figure 37.18b is obtained only when the lens is ground to a perfectly symmetric curvature. Variations from such symmetry might produce a pattern like that shown in Figure 37.19. These variations indicate how the lens must be reground and repolished to remove the imperfections.

Problem-Solving Hints

Thin-Film Interference

You should keep the following ideas in mind when you work thin-film interference problems:

- Identify the thin film causing the interference.
- The type of interference that occurs is determined by the phase relationship between the portion of the wave reflected at the upper surface of the film and the portion reflected at the lower surface.
- Phase differences between the two portions of the wave have two causes: (1) differences in the distances traveled by the two portions and (2) phase changes that may occur upon reflection.
- When the distance traveled and phase changes upon reflection are both taken into account, the interference is constructive if the equivalent path difference between the two waves is an integral multiple of λ , and it is destructive if the path difference is $\lambda/2$, $3\lambda/2$, $5\lambda/2$, and so forth.

QuickLab

Observe the colors appearing to swirl on the surface of a soap bubble. What do you see just before a bubble bursts? Why?

EXAMPLE 37.3 Interference in a Soap Film

Calculate the minimum thickness of a soap-bubble film ($n = 1.33$) that results in constructive interference in the reflected light if the film is illuminated with light whose wavelength in free space is $\lambda = 600$ nm.

Solution The minimum film thickness for constructive interference in the reflected light corresponds to $m = 0$ in Equation 37.16. This gives $2nt = \lambda/2$, or

$$t = \frac{\lambda}{4n} = \frac{600 \text{ nm}}{4(1.33)} = 113 \text{ nm}$$

Exercise What other film thicknesses produce constructive interference?

Answer 338 nm, 564 nm, 789 nm, and so on.

EXAMPLE 37.4 Nonreflective Coatings for Solar Cells

Solar cells—devices that generate electricity when exposed to sunlight—are often coated with a transparent, thin film of silicon monoxide (SiO , $n = 1.45$) to minimize reflective losses from the surface. Suppose that a silicon solar cell ($n = 3.5$) is coated with a thin film of silicon monoxide for this purpose (Fig. 37.20). Determine the minimum film thickness that produces the least reflection at a wavelength of 550 nm, near the center of the visible spectrum.

Solution The reflected light is a minimum when rays 1 and 2 in Figure 37.20 meet the condition of destructive interference. Note that both rays undergo a 180° phase change upon reflection—ray 1 from the upper SiO surface and ray 2 from the lower SiO surface. The net change in phase due to reflection is therefore zero, and the condition for a reflection minimum requires a path difference of $\lambda_n/2$. Hence,

$2t = \lambda/2n$, and the required thickness is

$$t = \frac{\lambda}{4n} = \frac{550 \text{ nm}}{4(1.45)} = 94.8 \text{ nm}$$

A typical uncoated solar cell has reflective losses as high as 30%; a SiO coating can reduce this value to about 10%. This significant decrease in reflective losses increases the cell's efficiency because less reflection means that more sunlight enters the silicon to create charge carriers in the cell. No coating can ever be made perfectly nonreflecting because the required thickness is wavelength-dependent and the incident light covers a wide range of wavelengths.

Glass lenses used in cameras and other optical instruments are usually coated with a transparent thin film to reduce or eliminate unwanted reflection and enhance the transmission of light through the lenses.

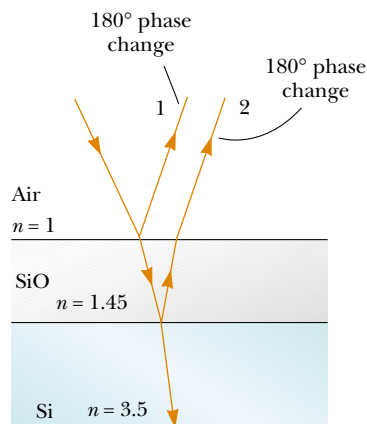

Figure 37.20 Reflective losses from a silicon solar cell are minimized by coating the surface of the cell with a thin film of silicon monoxide.



This camera lens has several coatings (of different thicknesses) that minimize reflection of light waves having wavelengths near the center of the visible spectrum. As a result, the little light that is reflected by the lens has a greater proportion of the far ends of the spectrum and appears reddish-violet.

EXAMPLE 37.5 Interference in a Wedge-Shaped Film

A thin, wedge-shaped film of refractive index n is illuminated with monochromatic light of wavelength λ , as illustrated in Figure 37.21a. Describe the interference pattern observed for this case.

Solution The interference pattern, because it is created by a thin film of variable thickness surrounded by air, is a series of alternating bright and dark parallel fringes. A dark fringe corresponding to destructive interference appears at point O , the apex, because here the upper reflected ray undergoes a 180° phase change while the lower one undergoes no phase change.

According to Equation 37.17, other dark minima appear when $2nt = m\lambda$; thus, $t_1 = \lambda/2n$, $t_2 = \lambda/n$, $t_3 = 3\lambda/2n$, and so on. Similarly, the bright maxima appear at locations where

the thickness satisfies Equation 37.16, $2nt = (m + \frac{1}{2})\lambda$, corresponding to thicknesses of $\lambda/4n$, $3\lambda/4n$, $5\lambda/4n$, and so on.

If white light is used, bands of different colors are observed at different points, corresponding to the different wavelengths of light (see Fig. 37.21b). This is why we see different colors in soap bubbles.

Figure 37.21 (a) Interference bands in reflected light can be observed by illuminating a wedge-shaped film with monochromatic light. The darker areas correspond to regions where rays tend to cancel each other because of interference effects. (b) Interference in a vertical film of variable thickness. The top of the film appears darkest where the film is thinnest.

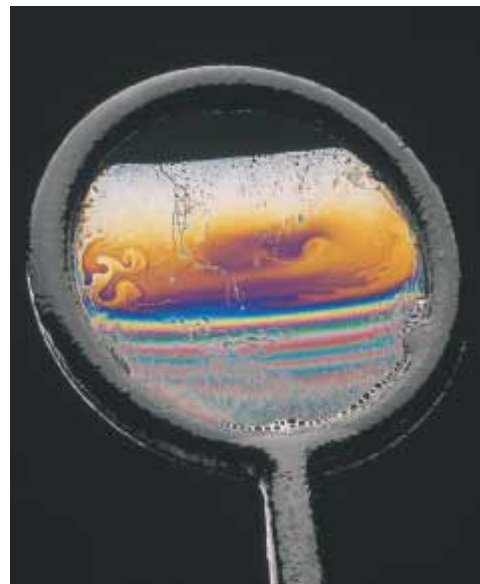
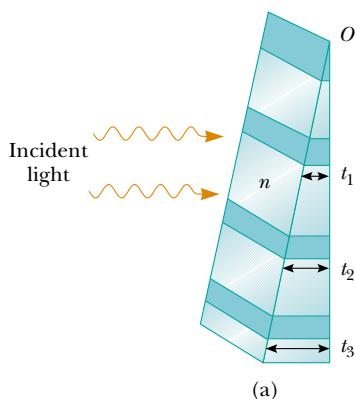
Optional Section**37.7** THE MICHELSON INTERFEROMETER

The **interferometer**, invented by the American physicist A. A. Michelson (1852–1931), splits a light beam into two parts and then recombines the parts to form an interference pattern. The device can be used to measure wavelengths or other lengths with great precision.

A schematic diagram of the interferometer is shown in Figure 37.22. A ray of light from a monochromatic source is split into two rays by mirror M , which is inclined at 45° to the incident light beam. Mirror M , called a *beam splitter*, transmits half the light incident on it and reflects the rest. One ray is reflected from M vertically upward toward mirror M_1 , and the second ray is transmitted horizontally through M toward mirror M_2 . Hence, the two rays travel separate paths L_1 and L_2 . After reflecting from M_1 and M_2 , the two rays eventually recombine at M to produce an interference pattern, which can be viewed through a telescope. The glass plate P , equal in thickness to mirror M , is placed in the path of the horizontal ray to ensure that the two returning rays travel the same thickness of glass.

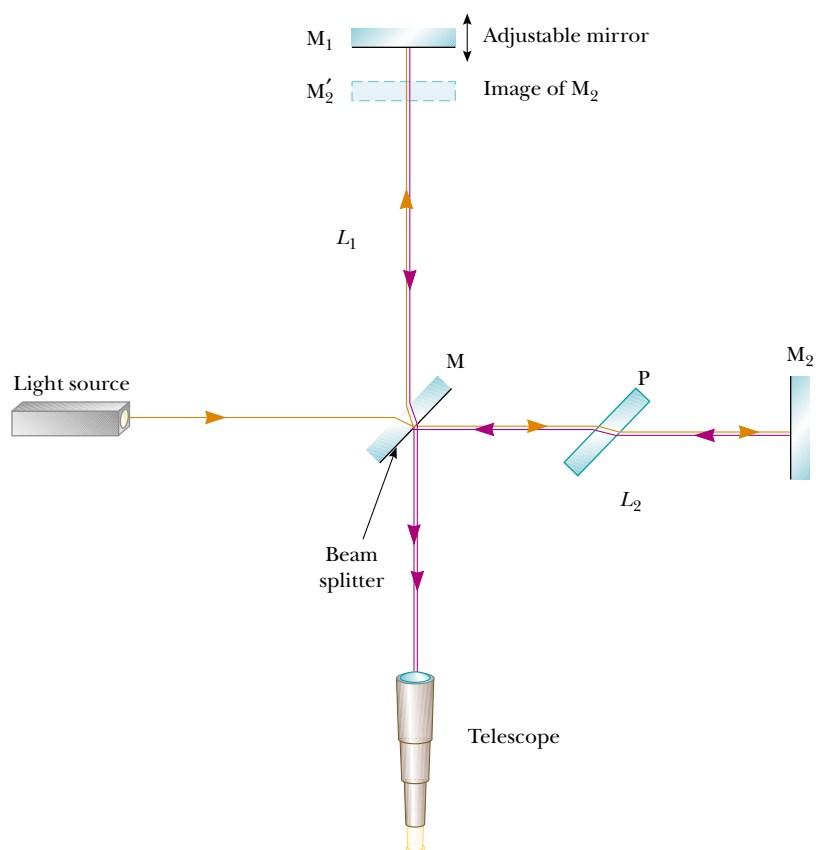

Figure 37.22 Diagram of the Michelson interferometer. A single ray of light is split into two rays by mirror M, which is called a beam splitter. The path difference between the two rays is varied with the adjustable mirror M_1 . As M_1 is moved toward M, an interference pattern moves across the field of view.

The interference condition for the two rays is determined by their path length differences. When the two rays are viewed as shown, the image of M_2 produced by the mirror M is at M'_2 , which is nearly parallel to M_1 . (Because M_1 and M_2 are not exactly perpendicular to each other, the image M'_2 is at a slight angle to M_1 .) Hence, the space between M'_2 and M_1 is the equivalent of a wedge-shaped air film. The effective thickness of the air film is varied by moving mirror M_1 parallel to itself with a finely threaded screw adjustment. Under these conditions, the interference pattern is a series of bright and dark parallel fringes as described in Example 37.5. As M_1 is moved, the fringe pattern shifts. For example, if a dark fringe appears in the field of view (corresponding to destructive interference) and M_1 is then moved a distance $\lambda/4$ toward M, the path difference changes by $\lambda/2$ (twice the separation between M_1 and M'_2). What was a dark fringe now becomes a bright fringe. As M_1 is moved an additional distance $\lambda/4$ toward M, the bright fringe becomes a dark fringe. Thus, the fringe pattern shifts by one-half fringe each time M_1 is moved a distance $\lambda/4$. The wavelength of light is then measured by counting the number of fringe shifts for a given displacement of M_1 . If the wavelength is accurately known (as with a laser beam), mirror displacements can be measured to within a fraction of the wavelength.

SUMMARY

Interference in light waves occurs whenever two or more waves overlap at a given point. A sustained interference pattern is observed if (1) the sources are coherent and (2) the sources have identical wavelengths.

In Young's double-slit experiment, two slits S_1 and S_2 separated by a distance d are illuminated by a single-wavelength light source. An interference pattern consisting of bright and dark fringes is observed on a viewing screen. The condition for bright fringes (**constructive interference**) is

$$d \sin \theta = m\lambda \quad m = 0, \pm 1, \pm 2, \dots \quad (37.2)$$

The condition for dark fringes (**destructive interference**) is

$$d \sin \theta = (m + \frac{1}{2})\lambda \quad m = 0, \pm 1, \pm 2, \dots \quad (37.3)$$

The number m is called the **order number** of the fringe.

The **intensity** at a point in the double-slit interference pattern is

$$I = I_{\max} \cos^2\left(\frac{\pi d \sin \theta}{\lambda}\right) \quad (37.12)$$

where I_{\max} is the maximum intensity on the screen and the expression represents the time average.

A wave traveling from a medium of index of refraction n_1 toward a medium of index of refraction n_2 undergoes a 180° phase change upon reflection when $n_2 > n_1$ and undergoes no phase change when $n_2 < n_1$.

The condition for constructive interference in a film of thickness t and refractive index n surrounded by air is

$$2nt = (m + \frac{1}{2})\lambda \quad m = 0, 1, 2, \dots \quad (37.16)$$

where λ is the wavelength of the light in free space.

Similarly, the condition for destructive interference in a thin film is

$$2nt = m\lambda \quad m = 0, 1, 2, \dots \quad (37.17)$$

QUESTIONS

- What is the necessary condition on the path length difference between two waves that interfere (a) constructively and (b) destructively?
- Explain why two flashlights held close together do not produce an interference pattern on a distant screen.
- If Young's double-slit experiment were performed under water, how would the observed interference pattern be affected?
- In Young's double-slit experiment, why do we use monochromatic light? If white light is used, how would the pattern change?
- Consider a dark fringe in an interference pattern, at which almost no light is arriving. Light from both slits is arriving at this point, but the waves are canceling. Where does the energy go?
- An oil film on water appears brightest at the outer regions, where it is thinnest. From this information, what can you say about the index of refraction of oil relative to that of water?
- In our discussion of thin-film interference, we looked at light *reflecting* from a thin film. Consider one light ray, the direct ray, that transmits through the film without reflecting. Consider a second ray, the reflected ray, that transmits through the first surface, reflects from the second, reflects again from the first, and then transmits out into the air, parallel to the direct ray. For normal incidence, how thick must the film be, in terms of the wavelength of light, for the outgoing rays to interfere destructively? Is it the same thickness as for reflected destructive interference?
- Suppose that you are watching television connected to an antenna rather than a cable system. If an airplane flies near your location, you may notice wavering ghost images in the television picture. What might cause this?
- If we are to observe interference in a thin film, why must the film not be very thick (on the order of a few wavelengths)?
- A lens with outer radius of curvature R and index of re-

fraction n rests on a flat glass plate, and the combination is illuminated with white light from above. Is there a dark spot or a light spot at the center of the lens? What does it mean if the observed rings are noncircular?

PROBLEMS

1, 2, 3 = straightforward, intermediate, challenging □ = full solution available in the *Student Solutions Manual and Study Guide*

WEB = solution posted at <http://www.saunderscollege.com/physics/>  = Computer useful in solving problem  = Interactive Physics

 = paired numerical/symbolic problems

Section 37.1 Conditions for Interference

Section 37.2 Young's Double-Slit Experiment

- A laser beam ($\lambda = 632.8 \text{ nm}$) is incident on two slits 0.200 mm apart. How far apart are the bright interference fringes on a screen 5.00 m away from the slits?
- A Young's interference experiment is performed with monochromatic light. The separation between the slits is 0.500 mm , and the interference pattern on a screen 3.30 m away shows the first maximum 3.40 mm from the center of the pattern. What is the wavelength?
- Two radio antennas separated by 300 m as shown in Figure P37.3 simultaneously broadcast identical signals at the same wavelength. A radio in a car traveling due north receives the signals. (a) If the car is at the position of the second maximum, what is the wavelength of the signals? (b) How much farther must the car travel to encounter the next minimum in reception? (*Note:* Do not use the small-angle approximation in this problem.)

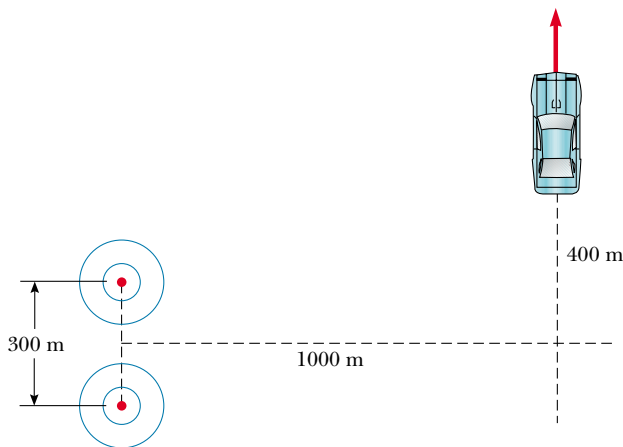

Figure P37.3

- In a location where the speed of sound is 354 m/s , a 2000-Hz sound wave impinges on two slits 30.0 cm apart. (a) At what angle is the first maximum located? (b) If the sound wave is replaced by 3.00-cm microwaves, what slit separation gives the same angle for the first maximum? (c) If the slit separation is $1.00 \mu\text{m}$, what frequency of light gives the same first maximum angle?

- Why is the lens on a high-quality camera coated with a thin film?
- Why is it so much easier to perform interference experiments with a laser than with an ordinary light source?

- Young's double-slit experiment is performed with 589-nm light and a slit-to-screen distance of 2.00 m . The tenth interference minimum is observed 7.26 mm from the central maximum. Determine the spacing of the slits.
- The two speakers of a boom box are 35.0 cm apart. A single oscillator makes the speakers vibrate in phase at a frequency of 2.00 kHz . At what angles, measured from the perpendicular bisector of the line joining the speakers, would a distant observer hear maximum sound intensity? minimum sound intensity? (Take the speed of sound as 340 m/s .)
- A pair of narrow, parallel slits separated by 0.250 mm are illuminated by green light ($\lambda = 546.1 \text{ nm}$). The interference pattern is observed on a screen 1.20 m away from the plane of the slits. Calculate the distance (a) from the central maximum to the first bright region on either side of the central maximum and (b) between the first and second dark bands.
- Light with a wavelength of 442 nm passes through a double-slit system that has a slit separation $d = 0.400 \text{ mm}$. Determine how far away a screen must be placed so that a dark fringe appears directly opposite both slits, with just one bright fringe between them.
- A riverside warehouse has two open doors, as illustrated in Figure P37.9. Its walls are lined with sound-absorbing material. A boat on the river sounds its horn. To person A, the sound is loud and clear. To person B, the sound is barely audible. The principal wavelength of the sound waves is 3.00 m . Assuming that person B is at the position of the first minimum, determine the distance between the doors, center to center.

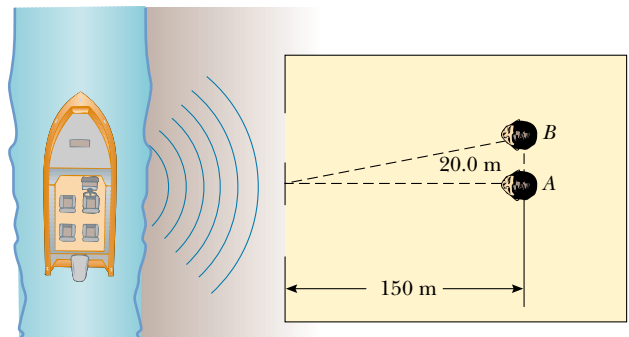

Figure P37.9

10. Two slits are separated by 0.320 mm. A beam of 500-nm light strikes the slits, producing an interference pattern. Determine the number of maxima observed in the angular range $-30.0^\circ < \theta < 30.0^\circ$.

11. In Figure 37.4 let $L = 1.20$ m and $d = 0.120$ mm, and assume that the slit system is illuminated with monochromatic 500-nm light. Calculate the phase difference between the two wavefronts arriving at point P when (a) $\theta = 0.500^\circ$ and (b) $y = 5.00$ mm. (c) What is the value of θ for which the phase difference is 0.333 rad? (d) What is the value of θ for which the path difference is $\lambda/4$?

12. Coherent light rays of wavelength λ strike a pair of slits separated by distance d at an angle of θ_1 , as shown in Figure P37.12. If an interference maximum is formed at an angle of θ_2 a great distance from the slits, show that $d(\sin \theta_2 - \sin \theta_1) = m\lambda$, where m is an integer.

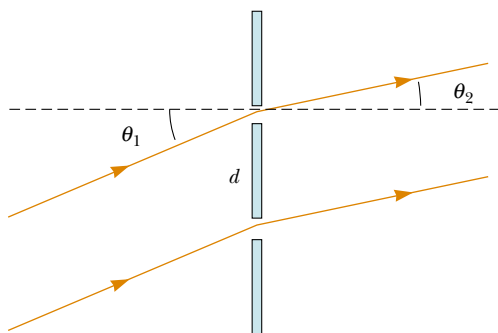

Figure P37.12

13. In the double-slit arrangement of Figure 37.4, $d = 0.150$ mm, $L = 140$ cm, $\lambda = 643$ nm, and $y = 1.80$ cm. (a) What is the path difference δ for the rays from the two slits arriving at point P ? (b) Express this path difference in terms of λ . (c) Does point P correspond to a maximum, a minimum, or an intermediate condition?

Section 37.3 Intensity Distribution of the Double-Slit Interference Pattern

14. The intensity on the screen at a certain point in a double-slit interference pattern is 64.0% of the maximum value. (a) What minimum phase difference (in radians) between sources produces this result? (b) Express this phase difference as a path difference for 486.1-nm light.

WEB 15. In Figure 37.4, let $L = 120$ cm and $d = 0.250$ cm. The slits are illuminated with coherent 600-nm light. Calculate the distance y above the central maximum for which the average intensity on the screen is 75.0% of the maximum.

16. Two slits are separated by 0.180 mm. An interference pattern is formed on a screen 80.0 cm away by 656.3-nm light. Calculate the fraction of the maximum intensity 0.600 cm above the central maximum.

17. Two narrow parallel slits separated by 0.850 mm are illuminated by 600-nm light, and the viewing screen is 2.80 m away from the slits. (a) What is the phase difference between the two interfering waves on a screen at a point 2.50 mm from the central bright fringe? (b) What is the ratio of the intensity at this point to the intensity at the center of a bright fringe?

18. Monochromatic coherent light of amplitude E_0 and angular frequency ω passes through three parallel slits each separated by a distance d from its neighbor. (a) Show that the time-averaged intensity as a function of the angle θ is

$$I(\theta) = I_{\max} \left[1 + 2 \cos \left(\frac{2\pi d \sin \theta}{\lambda} \right) \right]^2$$

(b) Determine the ratio of the intensities of the primary and secondary maxima.

Section 37.4 Phasor Addition of Waves

19. Marie Cornu invented phasors in about 1880. This problem helps you to see their utility. Find the amplitude and phase constant of the sum of two waves represented by the expressions

$$E_1 = (12.0 \text{ kN/C}) \sin(15x - 4.5t)$$

and

$$E_2 = (12.0 \text{ kN/C}) \sin(15x - 4.5t + 70^\circ)$$

(a) by using a trigonometric identity (see Appendix B) and (b) by representing the waves by phasors. (c) Find the amplitude and phase constant of the sum of the three waves represented by

$$E_1 = (12.0 \text{ kN/C}) \sin(15x - 4.5t + 70^\circ)$$

$$E_2 = (15.5 \text{ kN/C}) \sin(15x - 4.5t - 80^\circ)$$

and

$$E_3 = (17.0 \text{ kN/C}) \sin(15x - 4.5t + 160^\circ)$$

20. The electric fields from three coherent sources are described by $E_1 = E_0 \sin \omega t$, $E_2 = E_0 \sin(\omega t + \phi)$, and $E_3 = E_0 \sin(\omega t + 2\phi)$. Let the resultant field be represented by $E_P = E_R \sin(\omega t + \alpha)$. Use phasors to find E_R and α when (a) $\phi = 20.0^\circ$, (b) $\phi = 60.0^\circ$, and (c) $\phi = 120^\circ$. (d) Repeat when $\phi = (3\pi/2)$ rad.

WEB 21. Determine the resultant of the two waves $E_1 = 6.0 \sin(100\pi t)$ and $E_2 = 8.0 \sin(100\pi t + \pi/2)$.

22. Suppose that the slit openings in a Young's double-slit experiment have different sizes so that the electric fields and the intensities from each slit are different. If $E_1 = E_{01} \sin(\omega t)$ and $E_2 = E_{02} \sin(\omega t + \phi)$, show that the resultant electric field is $E = E_0 \sin(\omega t + \theta)$, where

$$E_0 = \sqrt{E_{01}^2 + E_{02}^2 + 2E_{01}E_{02} \cos \phi}$$

and

$$\sin \theta = \frac{E_{02} \sin \phi}{E_0}$$

23. Use phasors to find the resultant (magnitude and phase angle) of two fields represented by $E_1 = 12 \sin \omega t$ and $E_2 = 18 \sin(\omega t + 60^\circ)$. (Note that in this case the amplitudes of the two fields are unequal.)
24. Two coherent waves are described by the expressions

$$E_1 = E_0 \sin\left(\frac{2\pi x_1}{\lambda} - 2\pi ft + \frac{\pi}{6}\right)$$

$$E_2 = E_0 \sin\left(\frac{2\pi x_2}{\lambda} - 2\pi ft + \frac{\pi}{8}\right)$$

Determine the relationship between x_1 and x_2 that produces constructive interference when the two waves are superposed.

25. When illuminated, four equally spaced parallel slits act as multiple coherent sources, each differing in phase from the adjacent one by an angle ϕ . Use a phasor diagram to determine the smallest value of ϕ for which the resultant of the four waves (assumed to be of equal amplitude) is zero.
26. Sketch a phasor diagram to illustrate the resultant of $E_1 = E_{01} \sin \omega t$ and $E_2 = E_{02} \sin(\omega t + \phi)$, where $E_{02} = 1.50E_{01}$ and $\pi/6 \leq \phi \leq \pi/3$. Use the sketch and the law of cosines to show that, for two coherent waves, the resultant intensity can be written in the form $I_R = I_1 + I_2 + 2\sqrt{I_1 I_2} \cos \phi$.
27. Consider N coherent sources described by $E_1 = E_0 \sin(\omega t + \phi)$, $E_2 = E_0 \sin(\omega t + 2\phi)$, $E_3 = E_0 \sin(\omega t + 3\phi)$, . . . , $E_N = E_0 \sin(\omega t + N\phi)$. Find the minimum value of ϕ for which $E_R = E_1 + E_2 + E_3 + \dots + E_N$ is zero.

Section 37.5 Change of Phase Due to Reflection

Section 37.6 Interference in Thin Films

28. A soap bubble ($n = 1.33$) is floating in air. If the thickness of the bubble wall is 115 nm, what is the wavelength of the light that is most strongly reflected?
29. An oil film ($n = 1.45$) floating on water is illuminated by white light at normal incidence. The film is 280 nm thick. Find (a) the dominant observed color in the reflected light and (b) the dominant color in the transmitted light. Explain your reasoning.
30. A thin film of oil ($n = 1.25$) is located on a smooth, wet pavement. When viewed perpendicular to the pavement, the film appears to be predominantly red (640 nm) and has no blue color (512 nm). How thick is the oil film?
31. A possible means for making an airplane invisible to radar is to coat the plane with an antireflective polymer. If radar waves have a wavelength of 3.00 cm and the index of refraction of the polymer is $n = 1.50$, how thick would you make the coating?
32. A material having an index of refraction of 1.30 is used

to coat a piece of glass ($n = 1.50$). What should be the minimum thickness of this film if it is to minimize reflection of 500-nm light?

33. A film of MgF_2 ($n = 1.38$) having a thickness of 1.00×10^{-5} cm is used to coat a camera lens. Are any wavelengths in the visible spectrum intensified in the reflected light?
34. Astronomers observe the chromosphere of the Sun with a filter that passes the red hydrogen spectral line of wavelength 656.3 nm, called the H_α line. The filter consists of a transparent dielectric of thickness d held between two partially aluminized glass plates. The filter is held at a constant temperature. (a) Find the minimum value of d that produces maximum transmission of perpendicular H_α light, if the dielectric has an index of refraction of 1.378. (b) Assume that the temperature of the filter increases above its normal value and that its index of refraction does not change significantly. What happens to the transmitted wavelength? (c) The dielectric will also pass what near-visible wavelength? One of the glass plates is colored red to absorb this light.
35. A beam of 580-nm light passes through two closely spaced glass plates, as shown in Figure P37.35. For what minimum nonzero value of the plate separation d is the transmitted light bright?

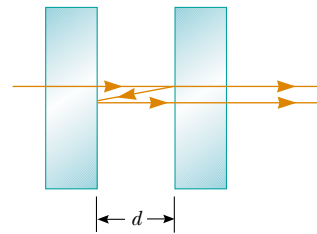

Figure P37.35

36. When a liquid is introduced into the air space between the lens and the plate in a Newton's-rings apparatus, the diameter of the tenth ring changes from 1.50 to 1.31 cm. Find the index of refraction of the liquid.
- WEB 37. An air wedge is formed between two glass plates separated at one edge by a very fine wire, as shown in Figure P37.37. When the wedge is illuminated from above by 600-nm light, 30 dark fringes are observed. Calculate the radius of the wire.



Figure P37.37 Problems 37 and 38.

38. Two rectangular flat glass plates ($n = 1.52$) are in contact along one end and separated along the other end by a sheet of paper 4.00×10^{-3} cm thick (see Fig. P37.37). The top plate is illuminated by monochromatic light ($\lambda = 546.1$ nm). Calculate the number of dark parallel bands crossing the top plate (include the dark band at zero thickness along the edge of contact between the two plates).
39. Two glass plates 10.0 cm long are in contact at one end and separated at the other end by a thread 0.050 0 mm in diameter. Light containing the two wavelengths 400 nm and 600 nm is incident perpendicularly. At what distance from the contact point is the next dark fringe?

(Optional)

Section 37.7 The Michelson Interferometer

40. Light of wavelength 550.5 nm is used to calibrate a Michelson interferometer, and mirror M_1 is moved 0.180 mm. How many dark fringes are counted?
41. Mirror M_1 in Figure 37.22 is displaced a distance ΔL . During this displacement, 250 fringe reversals (formation of successive dark or bright bands) are counted. The light being used has a wavelength of 632.8 nm. Calculate the displacement ΔL .
42. Monochromatic light is beamed into a Michelson interferometer. The movable mirror is displaced 0.382 mm; this causes the interferometer pattern to reproduce itself 1 700 times. Determine the wavelength and the color of the light.
43. One leg of a Michelson interferometer contains an evacuated cylinder 3.00 cm long having glass plates on each end. A gas is slowly leaked into the cylinder until a pressure of 1 atm is reached. If 35 bright fringes pass on the screen when light of wavelength 633 nm is used, what is the index of refraction of the gas?
44. One leg of a Michelson interferometer contains an evacuated cylinder of length L having glass plates on each end. A gas is slowly leaked into the cylinder until a pressure of 1 atm is reached. If N bright fringes pass on the screen when light of wavelength λ is used, what is the index of refraction of the gas?

ADDITIONAL PROBLEMS

45. One radio transmitter A operating at 60.0 MHz is 10.0 m from another similar transmitter B that is 180° out of phase with transmitter A . How far must an observer move from transmitter A toward transmitter B along the line connecting A and B to reach the nearest point where the two beams are in phase?
46. Raise your hand and hold it flat. Think of the space between your index finger and your middle finger as one slit, and think of the space between middle finger and ring finger as a second slit. (a) Consider the interference resulting from sending coherent visible light perpendicularly through this pair of openings. Compute an order-of-magnitude estimate for the angle between adja-

cent zones of constructive interference. (b) To make the angles in the interference pattern easy to measure with a plastic protractor, you should use an electromagnetic wave with frequency of what order of magnitude? How is this wave classified on the electromagnetic spectrum?

47. In a Young's double-slit experiment using light of wavelength λ , a thin piece of Plexiglas having index of refraction n covers one of the slits. If the center point on the screen is a dark spot instead of a bright spot, what is the minimum thickness of the Plexiglas?
48. **Review Problem.** A flat piece of glass is held stationary and horizontal above the flat top end of a 10.0-cm-long vertical metal rod that has its lower end rigidly fixed. The thin film of air between the rod and glass is observed to be bright by reflected light when it is illuminated by light of wavelength 500 nm. As the temperature is slowly increased by 25.0°C , the film changes from bright to dark and back to bright 200 times. What is the coefficient of linear expansion of the metal?
49. A certain crude oil has an index of refraction of 1.25. A ship dumps 1.00 m^3 of this oil into the ocean, and the oil spreads into a thin uniform slick. If the film produces a first-order maximum of light of wavelength 500 nm normally incident on it, how much surface area of the ocean does the oil slick cover? Assume that the index of refraction of the ocean water is 1.34.
50. Interference effects are produced at point P on a screen as a result of direct rays from a 500-nm source and reflected rays off the mirror, as shown in Figure P37.50. If the source is 100 m to the left of the screen and 1.00 cm above the mirror, find the distance y (in millimeters) to the first dark band above the mirror.

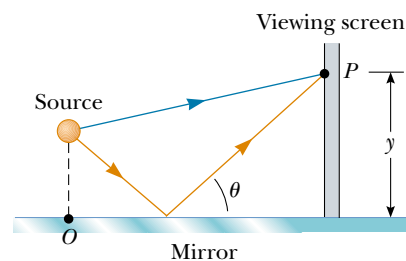
**Figure P37.50**

51. Astronomers observed a 60.0-MHz radio source both directly and by reflection from the sea. If the receiving dish is 20.0 m above sea level, what is the angle of the radio source above the horizon at first maximum?
52. The waves from a radio station can reach a home receiver by two paths. One is a straight-line path from transmitter to home, a distance of 30.0 km. The second path is by reflection from the ionosphere (a layer of ionized air molecules high in the atmosphere). Assume that this reflection takes place at a point midway between the receiver and the transmitter. The wavelength broadcast by the radio station is 350 m. Find the minimum height of the ionospheric layer that produces destructive inter-

ference between the direct and reflected beams. (Assume that no phase changes occur on reflection.)

53. Measurements are made of the intensity distribution in a Young's interference pattern (see Fig. 37.6). At a particular value of y , it is found that $I/I_{\max} = 0.810$ when 600-nm light is used. What wavelength of light should be used if the relative intensity at the same location is to be reduced to 64.0%?
54. In a Young's interference experiment, the two slits are separated by 0.150 mm, and the incident light includes light of wavelengths $\lambda_1 = 540$ nm and $\lambda_2 = 450$ nm. The overlapping interference patterns are formed on a screen 1.40 m from the slits. Calculate the minimum distance from the center of the screen to the point where a bright line of the λ_1 light coincides with a bright line of the λ_2 light.
55. An air wedge is formed between two glass plates in contact along one edge and slightly separated at the opposite edge. When the plates are illuminated with monochromatic light from above, the reflected light has 85 dark fringes. Calculate the number of dark fringes that would appear if water ($n = 1.33$) were to replace the air between the plates.
56. Our discussion of the techniques for determining constructive and destructive interference by reflection from a thin film in air has been confined to rays striking the film at nearly normal incidence. Assume that a ray is incident at an angle of 30.0° (relative to the normal) on a film with an index of refraction of 1.38. Calculate the minimum thickness for constructive interference if the light is sodium light with a wavelength of 590 nm.
57. The condition for constructive interference by reflection from a thin film in air as developed in Section 37.6 assumes nearly normal incidence. Show that if the light is incident on the film at a nonzero angle ϕ_1 (relative to the normal), then the condition for constructive interference is $2nt \cos \theta_2 = (m + \frac{1}{2})\lambda$, where θ_2 is the angle of refraction.
58. (a) Both sides of a uniform film that has index of refraction n and thickness d are in contact with air. For normal incidence of light, an intensity minimum is observed in the reflected light at λ_2 , and an intensity maximum is observed at λ_1 , where $\lambda_1 > \lambda_2$. If no intensity minima are observed between λ_1 and λ_2 , show that the integer m in Equations 37.16 and 37.17 is given by $m = \lambda_1/2(\lambda_1 - \lambda_2)$. (b) Determine the thickness of the film if $n = 1.40$, $\lambda_1 = 500$ nm, and $\lambda_2 = 370$ nm.
59. Figure P37.59 shows a radio wave transmitter and a receiver separated by a distance d and located a distance h above the ground. The receiver can receive signals both directly from the transmitter and indirectly from signals that reflect off the ground. Assume that the ground is level between the transmitter and receiver and that a 180° phase shift occurs upon reflection. Determine the longest wavelengths that interfere (a) constructively and (b) destructively.

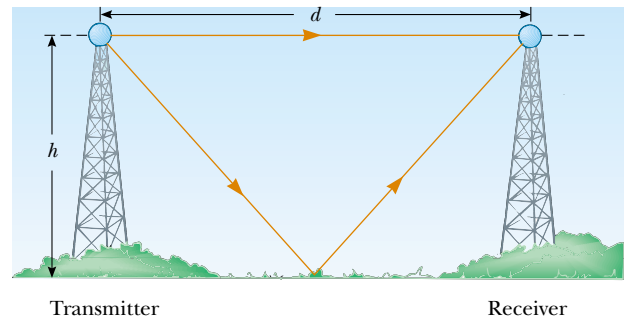

Figure P37.59

60. Consider the double-slit arrangement shown in Figure P37.60, where the separation d is 0.300 mm and the distance L is 1.00 m. A sheet of transparent plastic ($n = 1.50$) 0.050 0 mm thick (about the thickness of this page) is placed over the upper slit. As a result, the central maximum of the interference pattern moves upward a distance y' . Find y' .

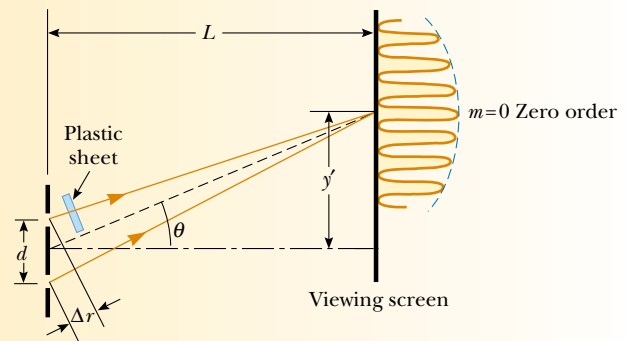

Figure P37.60 Problems 60 and 61.

61. Consider the double-slit arrangement shown in Figure P37.60, where the slit separation is d and the slit to screen distance is L . A sheet of transparent plastic having an index of refraction n and thickness t is placed over the upper slit. As a result, the central maximum of the interference pattern moves upward a distance y' . Find y' .
62. Waves broadcast by a 1 500-kHz radio station arrive at a home receiver by two paths. One is a direct path, and the other is from reflection off an airplane directly above the receiver. The airplane is approximately 100 m above the receiver, and the direct distance from station to home is 20.0 km. What is the precise height of the airplane if destructive interference is occurring? (Assume that no phase change occurs on reflection.)
63. In a Newton's-rings experiment, a plano-convex glass ($n = 1.52$) lens having a diameter of 10.0 cm is placed on a flat plate, as shown in Figure 37.18a. When 650-nm light is incident normally, 55 bright rings are observed, with the last ring right on the edge of the lens. (a) What is the radius of curvature of the convex surface of the lens? (b) What is the focal length of the lens?
64. A piece of transparent material having an index of re-

fraction n is cut into the shape of a wedge, as shown in Figure P37.64. The angle of the wedge is small, and monochromatic light of wavelength λ is normally incident from above. If the height of the wedge is h and the width is ℓ , show that bright fringes occur at the positions $x = \lambda \ell (m + \frac{1}{2}) / 2hn$ and that dark fringes occur at the positions $x = \lambda \ell m / 2hn$, where $m = 0, 1, 2, \dots$ and x is measured as shown.

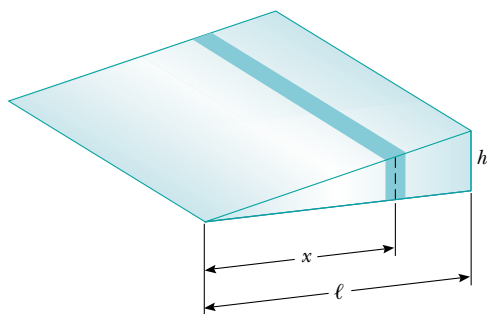

Figure P37.64

65. Use phasor addition to find the resultant amplitude and phase constant when the following three harmonic functions are combined: $E_1 = \sin(\omega t + \pi/6)$, $E_2 = 3.0 \sin(\omega t + 7\pi/2)$, $E_3 = 6.0 \sin(\omega t + 4\pi/3)$.
66. A plano-convex lens having a radius of curvature of $r = 4.00$ m is placed on a concave reflecting surface whose radius of curvature is $R = 12.0$ m, as shown in Figure P37.66. Determine the radius of the 100th bright ring if 500-nm light is incident normal to the flat surface of the lens.
67. A plano-convex lens has index of refraction n . The curved side of the lens has radius of curvature R and rests on a flat glass surface of the same index of refraction, with a film of index n_{film} between them. The lens is illuminated from above by light of wavelength λ . Show that the dark Newton's rings have radii given approximately by

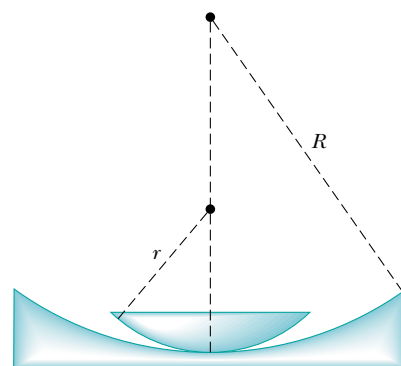

Figure P37.66

$$r \cong \sqrt{m\lambda R / n_{\text{film}}}$$

- where m is an integer and r is much less than R .
68. A soap film ($n = 1.33$) is contained within a rectangular wire frame. The frame is held vertically so that the film drains downward and becomes thicker at the bottom than at the top, where the thickness is essentially zero. The film is viewed in white light with near-normal incidence, and the first violet ($\lambda = 420$ nm) interference band is observed 3.00 cm from the top edge of the film. (a) Locate the first red ($\lambda = 680$ nm) interference band. (b) Determine the film thickness at the positions of the violet and red bands. (c) What is the wedge angle of the film?
69. Interference fringes are produced using Lloyd's mirror and a 606-nm source, as shown in Figure 37.14. Fringes 1.20 mm apart are formed on a screen 2.00 m from the real source S. Find the vertical distance h of the source above the reflecting surface.
70. Slit 1 of a double slit is wider than slit 2, so that the light from slit 1 has an amplitude 3.00 times that of the light from slit 2. Show that Equation 37.11 is replaced by the equation $I = (4I_{\text{max}}/9)(1 + 3 \cos^2 \phi/2)$ for this situation.

ANSWERS TO QUICK QUIZZES

- 37.1 Bands of light along the orange lines interspersed with dark bands running along the dashed black lines.
- 37.2 At location B. At A, which is on a line of constructive interference, the water surface undulates so much that you probably could not determine the depth. Because B is on a line of destructive interference, the water level does not change, and you should be able to read the ruler easily.
- 37.3 The graph is shown in Figure QQA37.1. The width of the primary maxima is slightly narrower than the $N = 5$ primary width but wider than the $N = 10$ primary width. Because $N = 6$, the secondary maxima are $\frac{1}{36}$ as intense as the primary maxima.
- 37.4 The greater the variation in thickness, the narrower the bands of color (like the lines on a topographic map). The widest bands are the gold ones along the left edge

of the photograph and at the bottom right corner of the razor blade. Thus, the thickness of the oil film changes most slowly with position in these areas.

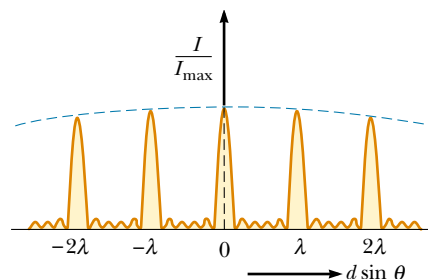

Figure QQA37.1